



Engineered Pipe and Tank Systems

# ENGINEERED PIPE & TANK SYSTEMS



[www.spirolite.my](http://www.spirolite.my)



**LESSO**  
Feel the better life



Production Facility



Spirolite Malaysia office

## SPIROLITE (M) SDN. BHD.

**A member of CHINA LESSO GROUP HOLDINGS LIMITED**  
(21438-U) (197401004289) (SST no.W10-1808-22000358)

Spirolite (M) Sdn. Bhd. is established in 1981 and is one of the leading Polyethylene (PE) pipes and tanks manufacturer in Malaysia with a total production capacity of 10,000 metric tons per annum.

Our PE Pipe, PE Spiral Pipe and PE Spiral Tank are certified by the Standard & Industrial Research Institute of Malaysia (SIRIM). All these products carry Suruhanjaya Perkhimatan Air Negara (SPAN) approval. Spirolite carries ISO 9001:2015 Quality Management System certification.

Spirolite products are widely being accepted in the domestic and overseas market for reliability and quality factor. We provide technical support and aftersales service to serve our customers.

Spirolite products are widely used by domestic Water Works Authorities, Public Work Department and Department of Irrigation and Drainage (DID). Our customers include housing developer, pipe laying contractor, infrastructure contractor, telecommunication service provider, M & E contractor, MRT contractor, landfill contractor and hardware wholesales dealer. Our products have been exported to Singapore, Indonesia, Sri Lanka, Cambodia, Brunei, Philippines, Myanmar, Hong Kong, Taiwan and Australia.

### Spirolite product range includes:

- PE Spiral Pipe**  
 culvert, drainage, sewerage, pipe jacking, pile sleeve, manhole and off-shore outflow and intake pipeline
- PE Pipe**  
 water, slurry, gas and chemical pipeline applications
- PE TNB Red Pipe**  
 TNB cable pipe ducting
- PE Telekom Black Pipe**  
 Telekom cable pipe ducting
- PE Water Tank**  
 water and industrial storage tank and scrubbers
- PE Flap Gate**  
 flood and river management
- Ribflo Pipe**  
 subsoil drainage and cable ducting
- PE Corrugated Sub-duct**  
 telecommunication ducting and soil nailing



# Contents

<b>Corporate Milestone</b>	<b>02</b>
----------------------------	-----------

---

## **1** PE Spiral Pipe **04**

---

General Specification	04	Standard Details	05
Advantage	04	Joining	06
Application	04		

## **2** PE Pipe **08**

---

General Specification	08	Standard Details	09
Advantage	08	Joining	12
Application	08		

## **3** PE Water Tank **13**

---

General Specification	13	Standard Details	14
Advantage	13		
Application	13		

## **4** PE Flap Gate **16**

---

General Specification	16	Standard Details	17
Advantage	16		
Application	16		

## **5** Single Wall Corrugated **20**

---

General Specification	20	Standard Details	20
Advantage	20		
Application	20		

## **6** Ribflo Pipe **21**

---

General Specification	21	Standard Details	22
Advantage	21	Joining	22
Application	21		

## **7** Engineering Products **23**

---

Introduction	23		
Types of engineered product	23		



## SPIROLITE (M) SDN. BHD.

A member of CHINA LESSO GROUP HOLDINGS LIMITED

**1981**

Established since 1981, manufacturing Spiral PE Pipes and PE Tanks at Malaysia, a production technology brought from Germany.

**1990**

Started manufacturing straight extruded PE pipe for water applications.

**1993**

Undertook the manufacturing of PE corrugated pipe for sub-soil and sub-duct applications.

**2013**

Spirolite (M) Sdn Bhd changed of equity interest from IJM Corporation Bhd to become wholly owned subsidiaries of Wah Seong Corporation Bhd

**2012**

Installed 3 extruder lines to produce PE pipes up to 450mm OD

**2001**

Awarded MS ISO9002:1994 Quality Systems Certification by SIRIM QAS Sdn Bhd and subsequently upgraded to MS ISO9001:2008.

**2014**

Installed a brand new corrugated sub-duct machine for pipe up to 50mm diameter.

**2015**

Installed a brand new extrusion line for pipes up to 630mm OD

**2016**

Spirolite Myanmar Co. Ltd commenced manufacturing activities.

**2020**

Spirolite (M) Sdn Bhd and Spirolite Myanmar Co. Ltd intergrated as part of China Lesso Group





China Lesso Group Holdings Limited (Stock Name: China Lesso, Stock Code: 02128.HK) is a large industrial group of home furnishings and building materials in China. China Lesso offers products, services and channels involving piping, building materials and home furnishings, environmental protection, and modern agriculture. Its product portfolio spans piping, plumbing and sanitary ware, integral kitchen materials, integral doors and windows, decorative plates, water purifiers, water-proofing materials and sealants, fire-fighting equipment, valves, cables, lighting, hygiene materials, items for environmental protection, agricultural facilities, and oceanic aquaculture cages. Its sales revenue has reached RMB 26.345 billion in 2019.

With the rapid development of internationalization and globalization, China Lesso boasts more than 80 holding subsidiaries and more than 23 production bases distributed in 18 provinces across China, and in Canada and Indonesia. China Lesso remains committed to improving its strategic layout, broadening its sales network and expanding the market. This is how it provides products and services for customers in a timely and efficient way.

China Lesso has established its R&D center with more than 1,000 scientific researchers. The Group now boasts ten national high-tech enterprises, one national accredited enterprise technology center, two post-doctoral workstations, five China national accredited laboratories authorized by CNAS, one key enterprise laboratory of plastics molding and processing technology in Guangdong Province, and one union of Technical Innovation of Plastic Pipe Industry in Guangdong Province.

China Lesso owns about 1817 patents (some of them are pending). Some of Lesso's scientific achievements are included in National Torch Plan Projects, National Key New Product, Scientific Achievements Promotion Projects in National Construction Industry and Government Green Procurement List. The Group has been awarded many honorary titles and prizes, such as Champion Manufacturer, China Construction Independent Science Innovation Superior Enterprise, Intellectual Property Right Preponderant Enterprise, Industrialization Demonstration Base, Guangdong Provincial Government Quality Prize, and the First Prize of Scientific Technological Progress in Guangdong Province, and the First Prize of Scientific Technological Progress of China Light Industry Association.

As a domestic manufacturer of extensive home furnishings and building materials, China Lesso offers over 10,000 varieties of products with all specifications. Its products are being widely used in many areas, including home decoration, civil construction, municipal water supply, drainage, power supply and telecommunications, gas supply, fire-fighting, environmental protection, agriculture and oceanic aquaculture.

True to its mission of "Creating a Relaxing Life", China Lesso will present a brand new image and offer more high cost-effective products and services to customers so that they can enjoy a comfortable and quality life.

# 1 PE SPIRAL PIPE



## INTRODUCTION

There is an increasing awareness of serious corrosion problems of conventional materials and growing concern about exfiltration problems are the main reasons for the application of our innovative, light, inert and large diameter SPIRAL high density polyethylene pipeline system.

SPIRAL pipe system offers a wide range of fittings, manholes and other by-products (eg float, rubbish chute & etc), which are also manufactured by specially designed profile-extrusion process and fabricated by extrusion welding.

## GENERAL SPECIFICATION

**Material:**

PE100

**Certified Standard:**

DIN 16961 : PART 2: 2010

**Size:**

ID 300mm through 3000mm availability

**Colour:**

Black

## ADVANTAGE

- Tough
- Light Weight and Easy to Transport
- High Chemical Resistance
- High Abrasion Resistance
- Corrosion Resistance
- Longer Service Life
- Excellent Hydraulics
- Economical / Easier Installation
- Low Cost Handling at Site

## APPLICATION

- Sewerage Pipelines
- Drainage Pipelines
- Culverts
- Effluent Lines
- Slurry Lines
- Irrigation
- Waste Gas Ducts and Ventilation
- Manhole / Manhole Drop
- Sea Outfall
- Relining of Old Pipelines
- Slotted Drain Application
- Floats
- Rubbish Chutes for High-Rise Buildings
- On Site Detention System (OSD)
- Pipe Jacket – to protect chilled steel water pipe, its annular space filled with foam for insulation
- Pipe Sleeve – to repair or erect new jetty pillar and for marine pile protection and rehabilitation.

STANDARD DETAILS

Profile Dimension of SPIROLITE HDPE Spiral Pipe

Profile No	Cross Section	A cm	s cm	H cm	d cm	l cm <sup>4</sup> /cm	e cm	S <sub>eff</sub> cm
3		-	0.95	-	-	0.072	0.475	0.950
5		12.00	0.60	3.70	3.00	0.960	0.843	2.259
6		8.50	0.60	3.70	3.00	1.257	0.982	2.471
7		7.00	0.60	3.70	3.00	1.455	1.066	2.594
9S		8.50	0.65	3.75	3.00	2.113	1.235	2.938
10S		7.00	0.65	3.75	3.00	2.623	1.364	3.157
11S		7.00	0.70	3.80	3.00	3.263	1.466	3.396
12S		7.00	0.80	3.90	3.00	4.092	1.568	3.662
12S2	7.00	0.90	4.00	3.00	4.341	1.590	3.735	
14S		20.00	0.60	7.40	3.00	9.864	2.491	4.910
14S2		20.00	1.00	8.20	3.00	12.436	2.586	5.304
15S		11.00	0.60	7.40	3.00	13.077	2.729	5.394
16S		8.00	0.80	7.80	3.00	17.486	2.899	5.942
18S		8.00	1.00	8.20	3.00	19.206	2.967	6.131
20S		-	0.60	8.00	3.00	23.713	3.844	6.577
20S2		-	0.75	8.45	3.00	25.927	3.841	6.776
20S3		-	0.90	8.90	3.00	28.140	3.843	6.964
20S4		-	1.00	9.20	3.00	29.619	3.848	7.084
23S		12.00	0.60	11.10	3.00	47.537	4.668	8.294
23S2		12.00	0.90	12.00	3.00	50.811	4.676	8.480
23S3		12.00	1.00	12.30	3.00	53.001	4.684	8.600
26S		8.00	1.00	12.30	3.00	62.019	5.006	9.062

"SPIRAL" Pipes Data  
Pipe Standard : DIN 16961

ID	0.4, Series 2, Class E			0.8, Series 3, Class F			1.6, Series 4, Class G		
	Profile No	Overall Thickness mm	Weight kg/m	Profile No	Overall Thickness mm	Weight kg/m	Profile No	Overall Thickness mm	Weight kg/m
300	-	-	-	-	-	-	5	37.0	11
400	-	-	-	-	-	-	5	37.0	14
450	-	-	-	-	-	-	5	37.0	15
500	-	-	-	-	-	-	5	37.0	17
533	-	-	-	-	-	-	5	37.0	18
600	-	-	-	5	37.0	20	6	37.0	24
750	5	37.0	25	6	37.0	29	9S	37.5	30
800	5	37.0	26	6	37.0	31	10S	37.5	34
900	5	37.0	29	9S	37.5	36	12S	39.0	43
1000	6	37.0	38	10S	37.5	42	14S	74.0	93
1200	9S	37.5	47	12S2	40.0	61	14S	74.0	111
1500	12S	39.0	69	14S	74.0	137	18S	82.0	193
1800	14S	74.0	164	16S	78.0	190	23S	111.0	289
2000	14S	74.0	181	20S	80.0	298	23S	111.0	319
2365	16S	78.0	248	23S	111.0	373	-	-	-
3000	23S	111.0	467	-	-	-	-	-	-

## "SPIRAL" Pipes Data

### Pipe Standard : DIN 16961

SR 24 N/cm <sup>2</sup>			
RS (N/cm <sup>2</sup> )	0.4	0.8	1.6
ID	Class E	Class F	Class G
300	-	-	10.62
400	-	-	4.67
450	-	-	3.32
500	-	-	2.45
533	-	-	2.03
600	-	1.44	1.86
750	0.75	0.97	1.60
800	0.62	0.80	1.63
900	0.44	0.94	1.78
1000	0.42	0.85	3.00
1200	0.40	0.82	1.78
1500	0.40	0.93	1.78
1800	0.55	0.96	2.47
2000	0.40	0.93	1.82
2365	0.43	1.13	-
3000	0.57	-	-

P N/m			
RS (N/cm <sup>2</sup> )	0.4	0.8	1.6
ID	Class E	Class F	Class G
300	-	-	6,177
400	-	-	3,617
450	-	-	2,897
500	-	-	2,372
533	-	-	2,100
600	-	1,674	2,162
750	1,089	1,410	2,325
800	961	1,245	2,528
900	765	1,641	3,110
1000	809	1,651	5,816
1200	942	1,901	4,136
1500	1,166	2,711	5,183
1800	1,913	3,348	8,600
2000	1,562	3,611	948
2365	1,983	5,162	-
3000	3,287	-	-

#### Quick Guide on Burial Depth of Spirolite Spiral Pipe:

- Assumption: 160mm crusher run surrounds the pipe with 95% proctor density compaction
- Approximately Depth of Burial
- Class F : 1m to 4m
- Class G : 4m to 8m
- Standard Pipe Length :
- ID 300mm to 1500mm : 6 m/length
- ID 1800mm to 3000mm : 4 m/length
- Longer length can be custom made upon request (Maximum length is 12m)

#### Remarks:

- Above specifications subject to +/- 5% tolerance
- Other size can be custom made upon request

## JOINTING

### Types of Jointing for 'SPIRAL' Pipes

The following are the standard pipe joints used as per DIN 16961-1:2011-01

i

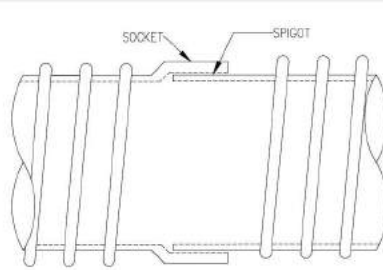

'SPIRAL' SOCKET AND SPIGOT JOINT

**Socket and Spigot joint**

- The pipes are produced with socket and spigot at both ends
- 2 pipe lengths are joined by slotting the spigot end into the socket end.

ii

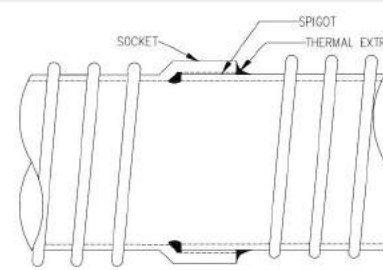

'SPIRAL' THERMAL EXTRUSION WELDED JOINT

**Thermal Extrusion Welded Joint**

- The pipes are produced with socket and spigot at both ends
- 2 pipe lengths are joined by slotting the spigot into the socket. Extrusion welding is performed either internally, externally or both at the joint.
- <900 ID External Weld Only
- >900 ID Internal Weld and External Weld Only



## JOINTING

iii

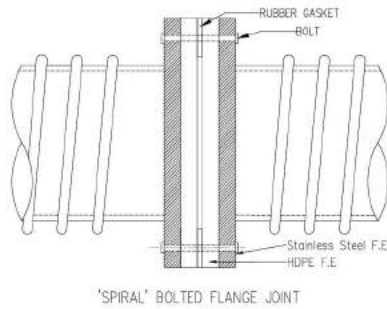
**Bolted Flanged Joint**

- PE flanges are made and welded to the actual pipe.
- Steel backing flanges are used to bolt the pipes together to enhance the strength of the PE flange
- Flanges of various type of standard can be provided
- Number of bolt holes varies with pipe diameters and applications.

iv

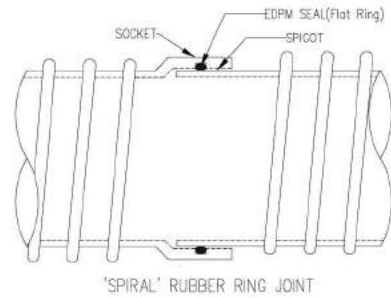
**Elastomeric Ring Joint**

- The pipes are produced with socket and spigot at both ends
- 2 pipe lengths are joined by slotting the spigot into the socket with elastomeric ring.
- This only available up to ID1200mm.

v

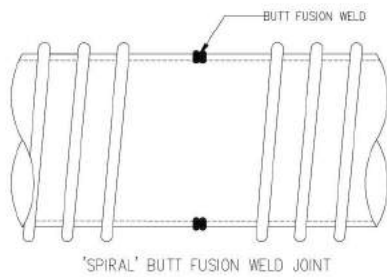
**Butt Fusion Weld Joint**

vi

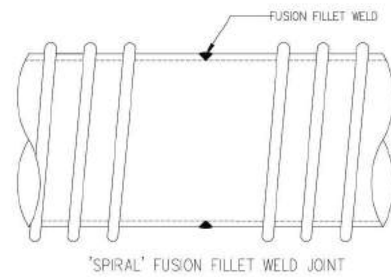
**Fusion Fillet Weld Joint**

# 2 PE PIPE



## INTRODUCTION

PE material exhibits a lot of advantages over traditional materials for pressure pipe applications. PE pipe also applicable for sewerage, drainage, sub-duct for electrical & telecommunication cabling

## GENERAL SPECIFICATION

**Material:**  
PE100

**Certified Standard:**

**Water Pipe:**

MS1058: PART 2: 2005

ISO4427: PART 2: 2019

**TNB:**

Certified Supplier of Tenaga Nasional

**Gas Pipe:**

MS1086: PART 2: 2007

ISO4437: PART 2: 2014

**Size:**

20mm through 630mm availability

**Pressure Rating:**

PN6, PN8, PN10, PN12.5, PN16, PN20

**Colour:**

**Water Supply:**

Black with blue stripes

**Electrical (TNB):**

Red

**Telecommunication:**

Black, Black with Orange stripes

**Sewer:**

Black with Brown stripes

**Gas:**

Yellow

## ADVANTAGE

- Corrosion Resistance : PE pipes are corrosion free
- Flexibility : Allows good conformity to most terrain contour
- Long Length and availability in coil (up to 125mmOD) : Enable jointless laying of longer pipe line
- Resistance to abrasion: Ability to handle many types of slurries and other abrasive elements
- Superior Flow: Smooth interior surface ensures good flow of water and prevent crust formation on the pipe
- Dampen/ Eliminate Water Hammer : Can withstand higher transient pressure than conventional pipes because of greater elasticity
- Tough and Durable: Has higher impact strength
- Lower Overall Cost: Significant cost saving in terms of transportation, cheaper installation and maintenance.
- Light Weight: 6-10 times lighter than conventional pipes
- Fully Welded Leak Free joints

## APPLICATION

- Water Supply
- Sewerage
- Drainage
- Sub-duct for electrical and telecommunication cabling
- Gas Supply

## STANDARD DETAILS

## SPIROLITE PE PIPE WEIGHT CHART (PE100)

## PE 100

SDR	26	21	17	13.6	11	9						
PN	6	8	10	12.5	16	20						
MINIMUM WALL THICKNESS (mm)												
OD(mm)	mm	kg/m	mm	kg/m	mm	kg/m	mm	kg/m	mm	kg/m	mm	kg/m
20							2.0	0.117	2.3	0.133		
25							2.0	0.149	2.3	0.171	3.0	0.212
32					2.0	0.194	2.4	0.231	3.0	0.279	3.6	0.328
40			2.0	0.246	2.4	0.295	3.0	0.362	3.7	0.431	4.5	0.512
50	2.0	0.311	2.4	0.373	3.0	0.453	3.7	0.550	4.6	0.669	5.6	0.793
63	2.5	0.492	3.0	0.578	3.8	0.722	4.7	0.877	5.8	1.057	7.1	1.266
75	2.9	0.674	3.6	0.828	4.5	1.019	5.6	1.242	6.8	1.476	8.4	1.779
90	3.5	0.978	4.3	1.188	5.4	1.465	6.7	1.780	8.2	2.139	10.1	2.566
110	4.2	1.435	5.3	1.782	6.6	2.180	8.1	2.636	10.0	3.172	12.3	3.813
125	4.8	1.848	6.0	2.278	7.4	2.780	9.2	3.397	11.4	4.115	14.0	4.932
160	6.2	3.060	7.7	3.741	9.5	4.555	11.8	5.553	14.6	6.732	17.9	8.044
180	6.9	3.809	8.6	4.699	10.7	5.760	13.3	7.046	16.4	8.506	20.1	10.175
200	7.7	4.726	9.6	5.825	11.9	7.111	14.7	8.645	18.2	10.495	22.4	12.587
225	8.6	5.938	10.8	7.360	13.4	9.019	16.6	10.977	20.5	13.282	25.2	15.930
250	9.6	7.357	11.9	9.006	14.8	11.052	18.4	13.522	22.7	16.334	27.9	19.577
280	10.7	9.177	13.4	11.370	16.6	13.885	20.6	16.943	25.4	20.478	31.3	24.609
315	12.1	11.691	15.0	14.288	18.7	17.583	23.2	21.473	28.6	25.922	35.2	31.132
355	13.6	14.775	16.9	18.142	21.1	22.379	26.1	27.225	32.2	32.907	39.7	39.540
400	15.3	18.735	19.1	23.133	23.7	28.282	29.4	34.524	36.3	41.777	44.7	50.155
450	17.2	23.688	21.5	29.254	26.7	35.832	33.1	43.731	40.9	52.902	50.3	63.504
500	19.1	29.225	23.9	36.098	29.7	44.280	36.8	53.967	45.4	65.285	55.8	78.262
560	21.4	36.634	26.7	45.180	33.2	55.472	41.2	67.708	50.8	81.787		
630	24.1	46.418	30.0	57.073	37.4	70.258	46.3	85.580	57.2	103.625		

**OD** : Outer Diameter  
**SDR** : Standard Dimension Ratio  
**PN** : Nominal Pressure

**STANDARD LENGTH**

Pipes from 20mm to 32mm OD supplied in coils of 100 metres of straight length of 6 or 12 meters.

Pipes from 40mm to 110mm OD supplied in coils of 50 and 100 metres or straight length of 6 or 12 meters.

Pipes from 110mm to 630mm OD supplied in straight length of 6 and 12 meters.

## STANDARD DETAILS

## PE TNB RED PIPE

**Note:**

- Installation method by Horizontal Directional Drilling (HDD) recommended to refer Table PE 80 Wall thickness Table
- Installation method by Open Trench recommended to refer Table PE 100 Wall thickness Table
- Jointing sockets are available upon request.

**PE 80**

<b>SDR</b>	13.6	11				
<b>PN</b>	10	12.5				
<b>WALL THICKNESS (mm)</b>						
<b>OUTER DIAMETER (mm)</b>	<b>Min (mm)</b>	<b>Max (mm)</b>	<b>Weight (kg/m)</b>	<b>Min (mm)</b>	<b>Max (mm)</b>	<b>Weight (kg/m)</b>
110	8.1	9.1	2.617	10.0	11.1	3.149
160	11.8	13.1	5.513	14.6	16.2	6.683
180	13.3	14.8	6.994	16.4	18.2	8.444
200	14.7	16.3	8.582	18.2	20.2	10.418
315	23.2	25.7	21.316	28.6	31.6	25.733

**PE 100**

<b>SDR</b>	17	13.6				
<b>PN</b>	10	12.5				
<b>WALL THICKNESS (mm)</b>						
<b>OUTER DIAMETER (mm)</b>	<b>Min (mm)</b>	<b>Max (mm)</b>	<b>Weight (kg/m)</b>	<b>Min (mm)</b>	<b>Max (mm)</b>	<b>Weight (kg/m)</b>
110	6.6	7.4	2.180	8.1	9.1	2.636
160	9.5	10.6	4.555	11.8	13.1	5.553
180	10.7	11.9	5.760	13.3	14.8	7.046
200	11.9	13.2	7.111	14.7	16.3	8.645
315	18.7	20.7	17.583	23.2	25.7	21.473

## STANDARD DETAILS

## PE TELEKOM BLACK PIPE

**Note:**

- Installation method by Horizontal Directional Drilling (HDD) recommended to refer Table PE 80 Wall thickness Table
- Installation method by Open Trench recommended to refer Table PE 100 Wall thickness Table
- Jointing sockets are available upon request.

**PE 80**

<b>SDR</b>	13.6			11		
<b>PN</b>	10			12.5		
WALL THICKNESS (mm)						
OUTER DIAMETER (mm)	Min (mm)	Max (mm)	Weight (kg/m)	Min (mm)	Max (mm)	Weight (kg/m)
110	8.1	9.1	2.617	10.0	11.1	3.149
160	11.8	13.1	5.513	14.6	16.2	6.683
180	13.3	14.8	6.994	16.4	18.2	8.444

**PE 100**

<b>SDR</b>	17			13.6		
<b>PN</b>	10			12.5		
WALL THICKNESS (mm)						
OUTER DIAMETER (mm)	Min (mm)	Max (mm)	Weight (kg/m)	Min (mm)	Max (mm)	Weight (kg/m)
110	6.6	7.4	2.180	8.1	9.1	2.636
160	9.5	10.6	4.555	11.8	13.1	5.553
180	10.7	11.9	5.760	13.3	14.8	7.046

## JOINTING

### 1) Mechanical Joint by Compression Fitting

Mechanical joint uses compression fitting type to perform the jointing. Compression fitting designed with many mechanical small parts which can hold the pipe tightly by using the compression force. This fitting can cater up to maximum 4 inch (110mm) diameter only. This is generally used for indoor. Lesso brand is available to supply upon request.

### 2) Butt Fusion Joint by Butt Fusion Fittings



The most widely used method for joining individual lengths of PE pipe and pipe to PE fittings is by heat fusion of the pipe butt ends. Lesso brand is available to supply upon request.

### 3) Butt Fusion Joint by Fabricated Fittings



Fabricated fittings usually will be use for larger diameter of PE pipe and pipe to PE fittings is by heat fusion of the pipe butt ends. Lesso brand is available to supply upon request.

### 4) Electrofusion



Electrofusion is a method of joining PE pipe using electrofusion fittings that have built-in electric heating elements which are used to weld and join the pipes and fittings together. Lesso Brand is available to supply. Lesso brand is available to supply upon request.

# 3 PE WATER TANK



## INTRODUCTION

SPIRAL PE Tanks are innovative thermoplastic static non-pressurized storage vessels and have been serving the needs for liquid storage in the housing as well as industrial sector since 1981. The versatility of Spiral PE Tanks makes them the ideal choice for the storage of water and a diverse range of chemicals, effluents and other corrosive materials. The Health Ministry of Malaysia also uses our Spiral PE Tanks in hospitals throughout Malaysia.

## GENERAL SPECIFICATION

**Material:**

PE100

**Certified Standard:**

MS1225:PART 1: 2014

MS1225: PART 2: 2006

**Size:**

300mm to 3,000mm in diameter and capacity up to 12,000 gallons

Certified by SIRIM and approved by SPAN

Manufactured using technology from Germany

## ADVANTAGE

- Chemical and Corrosion Resistance
- Environmental Resistance
- Inert and Non-Toxic Nature
- Durable
- Lightweight
- Easily Cleaned

## APPLICATION

- Roof storage tanks and suction tanks for apartments, condominiums and commercial buildings
- Small capacity individual tanks for housing estates
- Waste water treatment, chemical storage, de-gasifier, D.I. water treatment, flocculation tank
- Chemical mixing for industrial applications
- Storage water for irrigation and livestock for agricultural and poultry farms.

## STANDARD DETAILS

## TYPES OF TANK CONSTRUCTION

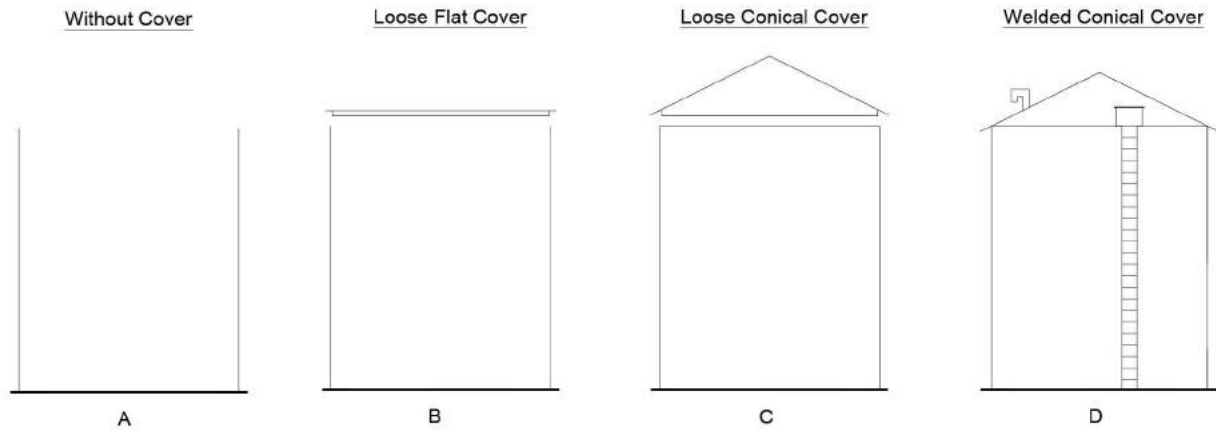

- Connection fittings such as inlet, outlet, overflow, scour etc. have a standard length of 100mm outside the tank outer surface (not including the length of stub end)
- Connection fittings mentioned above need to be welded both internally & externally, to make sure it is firm and stable during water flow
- Connection fittings mentioned above come with single PVC flange attached on it for connections with other pipelines during installation
- Lifting lugs are not necessary, but they are often present in standard design.
- The internal ladder rungs is made from PE
- The external ladder is made from Aluminum
- Manhole and Air Vent only applicable for Type D tank with Welded Conical Cover

## TANK DIMENSION

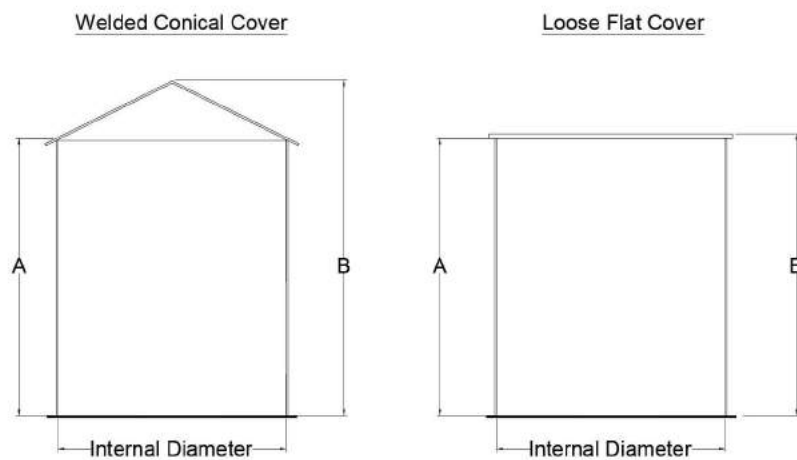

Note:  
 A = Internal Height  
 B = Overall Height



## STANDARD DETAILS

## SPIROLITE PE WATER TANK CHART

Capacity		Diameter (mm)		Internal Height	Overall Height (mm)		
(Gallons)	(Litres)	Internal Diameter	Base Diameter	(mm)	Type B	Type C	Type D
100	455	1000	1060	710	722	860	-
100	455	1200	1260	530	542	710	-
150	681	1200	1260	730	742	910	-
150	681	1500	1560	510	524	730	-
200	910	1200	1260	930	942	1100	-
200	910	1500	1560	640	654	860	-
250	1135	1200	1260	1130	1142	1300	-
250	1135	1500	1560	770	785	990	-
300	1365	1200	1260	1340	1355	1520	-
300	1365	1500	1560	900	915	1120	-
400	1820	1500	1560	1160	1175	1380	-
500	2270	1500	1560	1410	1425	1630	-
600	2730	1500	1560	1670	1685	1890	-
700	3180	1500	1560	1930	1945	2150	-
700	3180	1800	1880	1380	1395	1640	-
800	3640	1500	1560	2180	2195	2400	-
800	3640	1800	1880	1560	1575	1820	-
900	4095	1500	1560	2450	2465	2670	-
900	4095	1800	1880	1740	1755	2000	-
1000	4550	1500	1560	2700	2715	2920	-
1000	4550	1800	1880	1920	1935	2180	-
2000	9100	2365	2450	2215	-	-	2565
2000	9100	3000	3100	1410	-	-	1880
3000	13650	2365	2450	3230	-	-	3600
3000	13650	3000	3100	2050	-	-	2520
4000	18200	3000	3100	2700	-	-	3180
5000	22700	3000	3100	3340	-	-	3810
6000	27300	3000	3100	3990	-	-	4460
7000	31800	3000	3200	4620	-	-	5090
8000	36400	3000	3200	5270	-	-	5740
9000	40950	3000	3200	5920	-	-	6390
10000	45500	3000	3200	6560	-	-	7030
11000	50050	3000	3200	7215	-	-	7685
12000	54600	3000	3200	7850	-	-	8320

Note: We are able to customize the sizes to suit your specific requirements.

1 m<sup>3</sup> = 220 gallons    1 gallon = 4.55 litres

# 4 PE FLAP GATE

## INTRODUCTION

Spiral PE Flap Gate is designed to allow water to flow out for discharge and closed to prevent water to flow in to mitigate flooding of the area.



## GENERAL SPECIFICATION

**Material:**  
PE100

**Size:**  
Circular : ID 300mm through 3000mm  
Rectangular : Length 300mm through 3000mm availability

Irregular Size upon request

**Colour:**  
Black: Carbon Black content of the raw material used must be not less than 2% in weight. The requirement of the carbon black is to give UV protection from sunlight.

**Type of Flap Gate**  
PE Wall Mounted "Spiral" Flap Gate (Square Type)  
PE Wall Mounted "Spiral" Flap Gate (Circular Type)  
PE "Spiral" Flap Gate c/w Spiral Pipe

The flap door is designed to rest on the collar frame at an angle of 5° / 10° from the vertical plane.

## ADVANTAGE

- High quality PE material and easy installation
- High temperature and chemical resistance
- UV protection and corrosion proof
- Ability to withstand high water pressure

## APPLICATION

- Automatic operating control by hydro force
- To prevent back flow from storm rain in main river flow into lower land area
- Maintenance free and low head loss  
Suitable use for water, waste water and pipeline application
- Effective tidal and flood control

## STANDARD DETAILS

## A) WALL MOUNTED TYPE

- i. Circular wall mounted
- ii. Rectangular wall mounted

## 'SPIRAL' HDPE FLAP GATE - Wall mounted

## Type : Circular

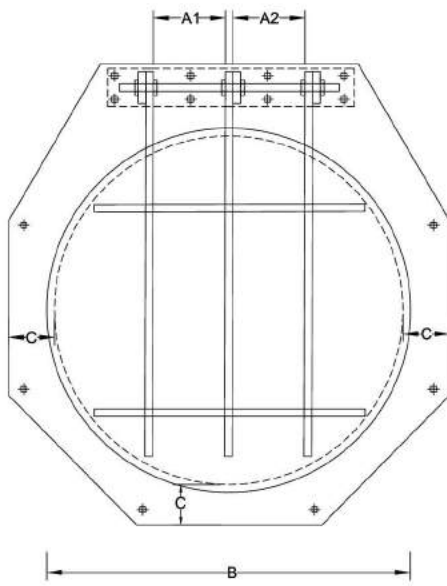

FRONT VIEW

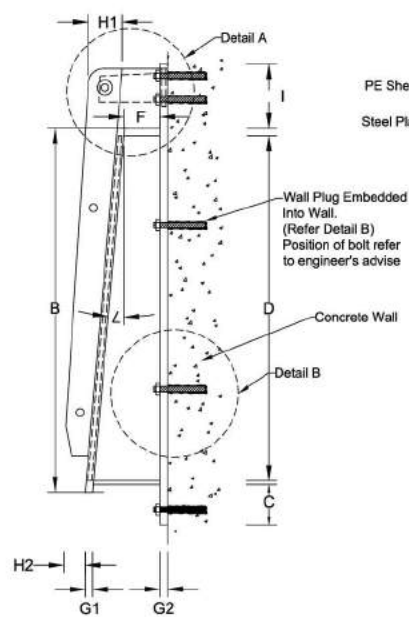

SIDE VIEW

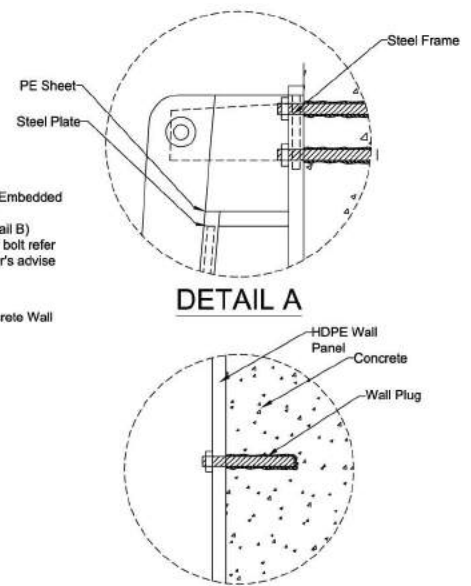

DETAIL B

## Schedule Data

MODEL	A1	A2	A3	A4	B	C	D	F	G1	G2	H1	H2	I	ANGLE
C300	130	NA	NA	NA	420	110	300	100	28.5	20	80	70	130	5°/10°
C450	180	NA	NA	NA	580	110	450	100	28.5	20	80	70	130	5°/10°
C600	200	NA	NA	NA	760	130	600	100	28.5	20	80	70	150	5°/10°
C750	210	NA	NA	NA	910	130	750	150	28.5	20	80	70	150	5°/10°
C900	280	NA	NA	NA	1060	130	900	150	28.5	20	100	80	240	5°/10°
C1000	310	NA	NA	NA	1160	130	1000	150	28.5	28	100	80	240	5°/10°
C1200	240	240	NA	NA	1360	150	1200	160	34	28	100	80	255	5°/10°
C1500	270	270	NA	NA	1680	150	1500	200	34	28	120	100	265	5°/10°
C1800	270	270	270	NA	1980	170	1800	240	36	28	120	100	285	5°/10°
C2000	300	300	300	NA	2180	170	2000	240	38	28	140	120	285	5°/10°
C2365	340	340	340	340	2560	180	2365	300	38	28	140	120	380	5°/10°
C3000	500	500	500	500	3180	180	3000	300	38	28	140	120	460	5°/10°

Note: All units in mm  
 All dimensions with tolerance  $\pm 20\text{mm}$  only G1 & G2  $\pm 5\text{mm}$   
 Drawing for reference only  
 The flap gates shall be of size and material grades as specified herein and as shown on drawings.  
 Custom made flap gate to suit site conditions is available upon request.

## STANDARD DETAILS

## 'SPIRAL' HDPE FLAP GATE - Wall mounted

Type : Rectangular

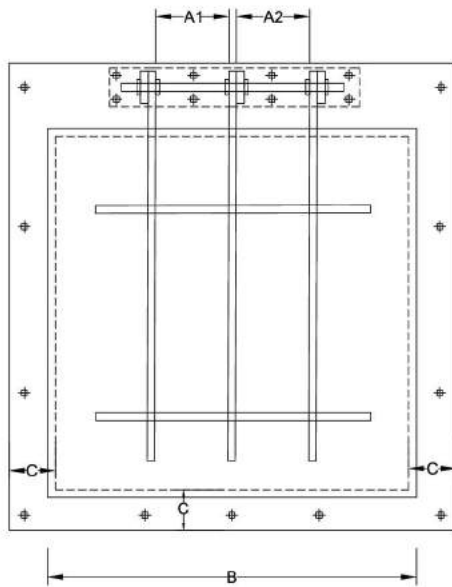

FRONT VIEW

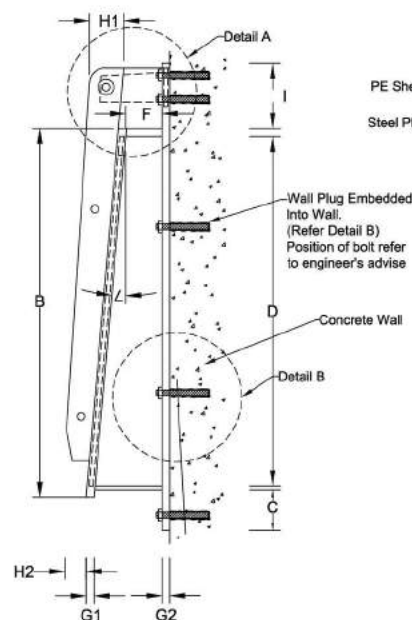

SIDE VIEW

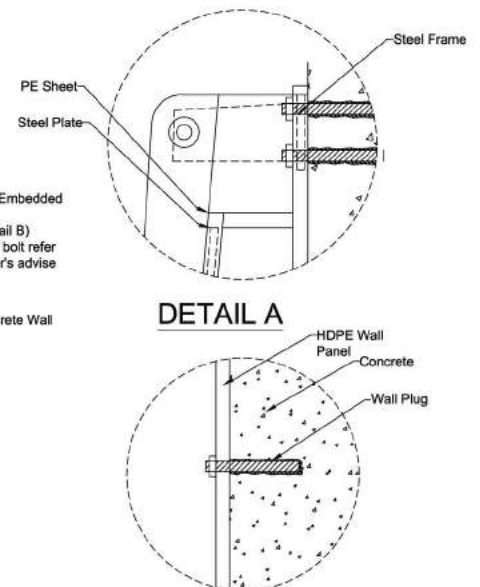

DETAIL B

## Schedule Data

MODEL	A1	A2	A3	A4	B	C	D	F	G1	G2	H1	H2	I	ANGLE
R600 X 600	230	NA	NA	NA	790	110	600	170	28.5	20	80	70	200	5°/10°
R700 X 700	310	NA	NA	NA	900	110	700	200	28.5	20	80	70	200	5°/10°
R900 X 900	350	NA	NA	NA	1100	130	900	220	30	20	100	80	240	5°/10°
R1000 X 1000	410	NA	NA	NA	1220	130	1000	220	30	28	100	80	240	5°/10°
R1200 X 1200	280	280	280	NA	1400	130	1200	220	34	28	100	80	250	5°/10°
R1500 X 1500	370	380	370	NA	1720	130	1500	220	34	28	120	100	260	5°/10°
R1800 X 1800	480	500	480	NA	2020	150	1800	220	36	28	120	100	260	5°/10°
R2000 X 2000	530	530	530	NA	2260	150	2000	220	38	28	140	120	260	5°/10°
R2100 X 2100	580	580	580	NA	2340	150	2100	240	38	28	140	120	260	5°/10°
R2400 X 2400	500	500	500	500	2660	170	2400	240	38	28	140	120	260	5°/10°
R3000 X 3000	650	650	650	650	3260	180	3000	240	38	28	140	120	260	5°/10°

Note: All units in mm  
 All dimensions with tolerance  $\pm 20\text{mm}$  only G1 & G2  $\pm 5\text{mm}$   
 Drawing for reference only  
 The flap gates shall be of size and material grades as specified herein and as shown on drawings.  
 Custom made flap gate to suit site conditions is available upon request.

## STANDARD DETAILS

## B) FLAP GATE ATTACHED WITH PE PIPE

## 'SPIRAL' HDPE FLAP GATE - attached with pipe

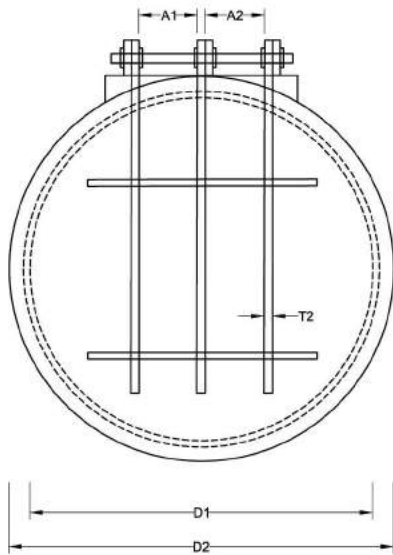

FRONT VIEW

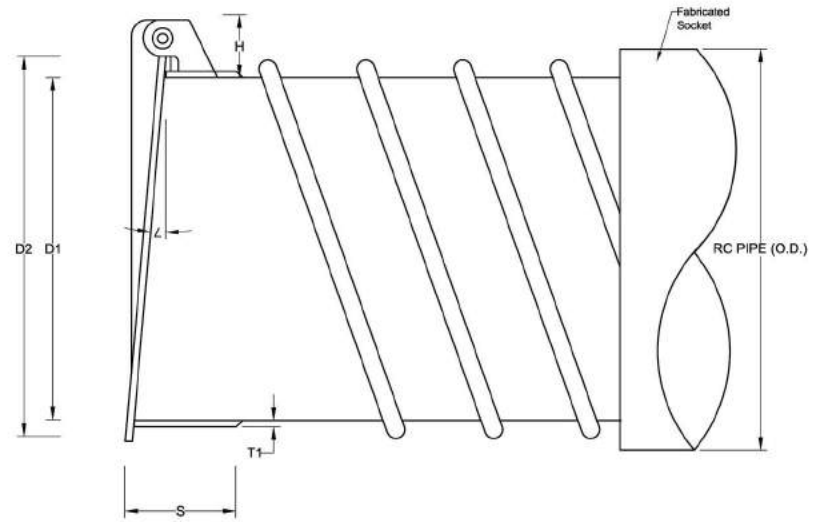

SIDE VIEW

## Schedule Data

PIPE DIAMETER	D1	D2	A1	A2	A3	H	T1	T2	S	ANGLE
P600	600	760	180	NA	NA	220	30	20	400	5°/10°
P900	900	1060	300	NA	NA	230	30	25	400	5°/10°
P1000	1000	1160	320	NA	NA	240	30	25	400	5°/10°
P1200	1200	1360	220	220	NA	250	30	25	400	5°/10°
P1500	1500	1680	250	250	NA	250	35	25	400	5°/10°
P1800	1800	1980	270	220	270	280	35	30	400	5°/10°

Note: All units in mm  
 All dimensions with tolerance  $\pm 20$ mm only T1 & T2  $\pm 10$ mm  
 Drawing for reference only  
 The flap gates shall be of size and material grades as specified herein and as shown on drawings.  
 Custom made flap gate to suit site conditions is available upon request.

# 5 SINGLE WALL CORRUGATED PE PIPE



## INTRODUCTION

Spirolite Single Wall Corrugated PE Pipe (Sub-duct) is made from PE resin that bonded with low friction with high tensile strength that enable easy placement of electric cable, telecommunication cable and fiber optic in the suitable diameter. The sub-duct is supplied with or without the Nylon rope. The nylon rope allows cable to be pulled from one end to another end of the long length sub-duct.

The sub-duct also used as conduit for soil nailing. Soil nailing is a technique in which soil slope, embankment or retaining wall is reinforced by the insertion of relatively slender elements that commonly use of steel bars. The steel bar is usually installed with the sub-duct into a pre-drilled hole and then grouted into place.

## GENERAL SPECIFICATION

**Material:**  
PE 100

**Size:**  
ND 32mm, 40mm, 50mm

## ADVANTAGE

- Easy to install or replace cable into an occupied ducts.
- Low installation or replacement cost
- Flexible, long range and light weight
- Come with nylon rope for ease of installation
- Easy to create additional ducting branches

## APPLICATION

- Electric, fiber optic and telecommunication ducting system.
- Cable protection pipe
- Building cable ducting system
- Conduit for soil nailing

## STANDARD DETAILS

### Pipe Data

NOMINAL DIAMETER (mm)	INTERNAL DIAMETER (mm)	STANDARD LENGHT (m/coil)
32	26	250
40	33	250
50	43	250

# 6 RIBFLO PIPE



## INTRODUCTION

Ribflo Corrugated Subsoil Drainage Pipe is made from PE resin that well known for its strong structural strength and durability as drainage or discharge pipe that suitable to install in any soil conditions. The corrugated profile is special designed to suit any trenching and soil conditions with objective to achieve perfect drainage system. The Ribflo pipes are normally installed in shallow buried depth without heavy traffic load.

The subsoil drainage pipe is available in both perforated and non-perforated design for various applications. With its uniform slot pattern throughout the pipes, drainage performance is guaranteed.

## GENERAL SPECIFICATION

**Material:**

PE 100

**Reference Standard:**

AS 2439 Part 1

**Size:**

ND 175mm, 100mm

Slotted area per meter of pipe can be as high as 1500mm<sup>2</sup> or more.

## ADVANTAGE

- Long lengths of coils to enable high speed installation with less joints
- Light Weight
- Even and efficient drainage through the uniform slot pattern
- Corrosion resistant
- Great flexibility

## APPLICATION

- Road and highway
- Swamp, plantation and agriculture land
- Retaining structure wall
- Garden, golf course, stadium and school field
- Leaches discharge pipe for landfill.
- Building Foundation

## STANDARD DETAILS

Production Data in accordance with AS 2439 Part 1

Dimension:

<b>Nominal Diameter (mm)</b>	175	100
<b>Internal Diameter (mm)</b>	150	85
<b>No. of Slotted Rows</b>	3	6
<b>Slot Area Per Meter of Pipe (mm<sup>2</sup>)</b>	>1500	>1500
<b>Length of Pipe Per Coil (m)</b>	50	100

Note:

For ND 175mm size is an OEM product

## JOINTING

To join RIBFLO:

Cut off a length approximately 250mm and slit it open lengthwise. Place the two ends to be joined together and snap the slit length equidistant over them. Normally, this is all you need to do. It is recommended to bind joints with light wire for extra strength.

Type of Fabricated Fitting:

Y-Joint, Tee-Joint, Reducer and End Cap



# 7 ENGINEERING PRODUCT



## INTRODUCTION

Since our inception in 1981, Spirolite continuously put the best effort to develop new products. Supported by experienced workforce, we are able to extend our expertise to meet client expectations in terms of product, quality, delivery lead time and pricing.

Riding on our successful experience, we have developed a few engineering products throughout the years.

## TYPE OF ENGINEERING PRODUCTS

\*CUSTOMIZABLE UPON REQUEST

### RUBBISH CHUTE

- Rubbish Chute: an inclined channel or vertical passage down which rubbish may be dropped for disposal.

DIAMETER (mm)	PROFILE NO.	MINIMUM WEIGHT (kg/m)	MINIMUM SOLID WALL THICKNESS
533	5	17	6
600	5	19	6
750	5	28	8
900	5	34	8



### FLOAT

In recent years we have seen constant increase in the number of floats or pontoons using our pipe as a floating material. Its popularity is due in part to its unique combination of lightweight flexibility, inertness to salt water and excellent buoyancy. Other floating pontoon applications for which our float can be use as a log boom by connecting our pipe with some other additional accessories at both pipe end.

## TYPE OF ENGINEERING PRODUCTS

\*CUSTOMIZABLE UPON REQUEST

## PILE PROTECTION SLEEVE

Corrosion of steel structures in marine environments is a common problem. Steel rusts and concrete corrodes quickly when exposed to sea water, fresh water or even just the elements in the average marine atmosphere. That is why it is important to find effective solutions to increase the lifespan of your marine assets.

The best way to prevent this is to encase your steel or concrete piling within our HDPE pile protection sleeve. HDPE pile sleeves provide the best wear protection (from abrasion, rubbing and UV light) and corrosion resistance available and are largely maintenance free, making them an ideal choice for marine applications.

Pile sleeves contain no toxins that can leach into ecosystems or



negatively impact water quality, unlike traditional methods such as heavy metal coatings. The pile sleeves will fit most size round piles. It can be customized by adding welded HDPE spacer for the pile prepare for concrete grouting.

## CAPSULE RESORT



The latest concept hotel in KL is playing with the idea of steel containers – the same kind used in cargo shipments. Inspired by the Japanese concept of 'Kyosho Jutaki' which means living large on a tiny footprint.

HDPE Spiral pipe had used as a new concept hotel that offers stays in unconventional cylindrical 'rooms' measuring 3m in diameter and 4m in length. Custom built end caps provide windows and a door on one side with curtains for privacy. Within these air-conditioned tubes, you'll find a comfy queen-sized bed, lamp and plug sockets and toilets. It's not big on space but it's cosy.

## MANHOLE

Spirolite produces manholes made of polyethylene in accordance with the customer's specifications. The diameter of a manhole depends on its purpose and the connected pipe sizes.

HDPE Manholes have a lot of special features that could be summarised in the below points:

- Light weight and easy to install.
- HDPE manholes offers a wide range of chemical resistance to acids, bases, and many organic compounds
- HDPE ladders can be fabricated inside the HDPE manhole when requested.
- Inlets and outlets are welding to assure leak free points.

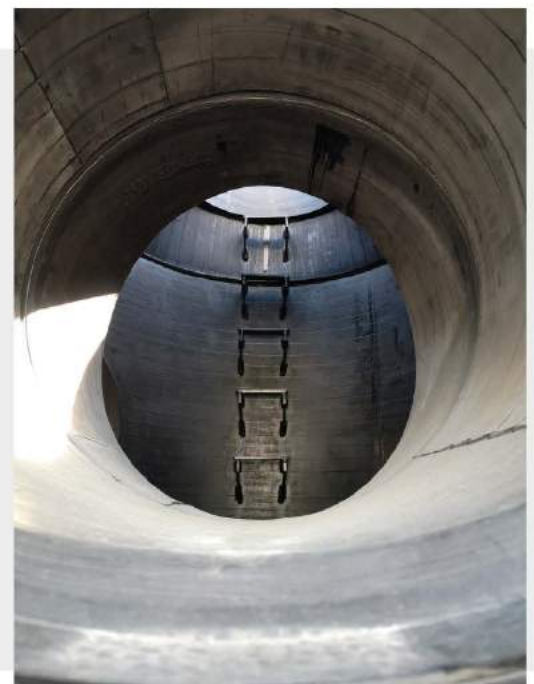



Engineered Pipe and Tank Systems



SABAH DISTRIBUTOR:

KEKALBOLEH SDN BHD  
(199901021248/496148-K)  
Lot No. 7, Lorong Perindustrian Kolombong Jaya,  
Pusat Perindustrian Kolombong Jaya,  
Mile 5.5, Jalan Kolombong,  
88450 Kota Kinabalu, Sabah.  
Tel/WhatsApp: 088-385555 / 013-8867570  
Website: kekalboleh.com



## SPIROLITE (M) SDN. BHD.

A member of CHINA LESSO GROUP HOLDINGS LIMITED  
(21438-U) (197401004289) (SST no.W10-1808-22000358)

Address : Lot 4, Jalan P/2A, Kawasan Perindustrian Bangi,  
43650 Bandar Baru Bangi, Selangor, Malaysia

Tel : +603 8925 0306  
Fax : +603 8925 3568  
E-mail : enquiries@spiro-lite.my  
Web : www.spirolite.my

Stock Code: 2128.HK