



GLOBAL PE PRODUCT OFFER

FOR GAS AND WATER



connect...

Through our **connect...** initiative, the Fusion Group strategy is to become the customers' preferred partner as the leading Manufacturer and Supplier of products and services for gas and water polyethylene pipeline systems, worldwide.....

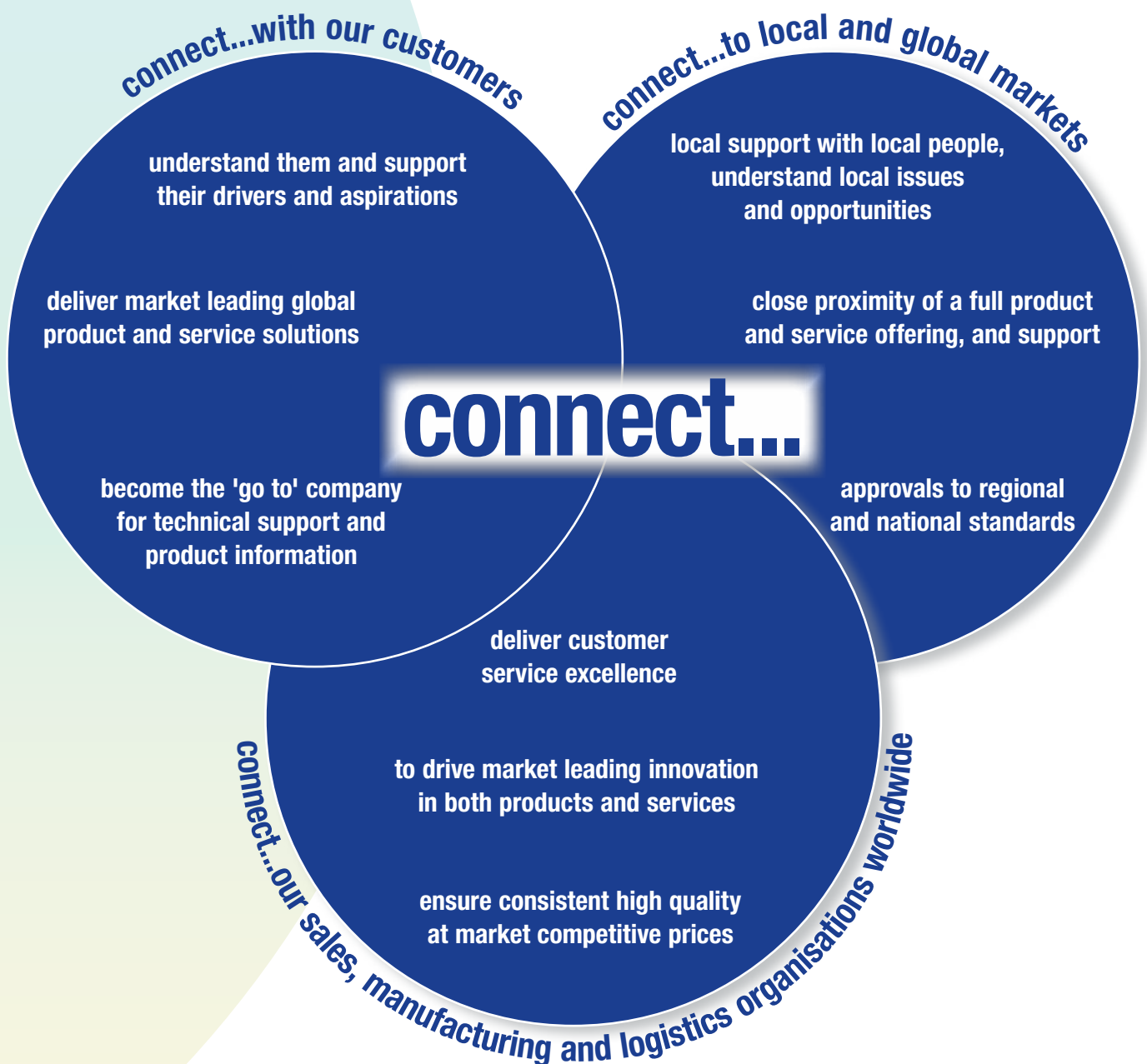

CONTENTS

PE Ball Valves		6 - 13
PE Butterfly Valves		14 - 17
Electrofusion Fittings		18 - 49
AVK Installation Tracker		30 - 31
Spigot Fittings		50 - 123
Transition Fittings		124 - 139
Flow Limitors		140 - 143
Equipment and Ancillaries		144 - 171
Access Systems		172 - 183

Delivery Codes

Throughout the Global PE Product Offer products are categorised into 3 delivery codes which are based on our delivery commitments, these are as follows;

A = Stocked product, delivery period to be agreed.

B = Non-stocked product, delivery period to be agreed.

C = Upon enquiry

Please email sales@fusiongroup.com or telephone +44(0)1246 268666 for further details regarding delivery commitments.



Fusion Group Limited pioneered polyethylene pipe jointing in the UK and across the globe. Fusion became a member of the AVK Group of Companies in 2017. This partnership has resulted in a broader product and service offer and has strengthened our manufacturing base.

Products and Innovations

Fusion designs and manufactures electrofusion fittings, creates polyethylene fabrications, and distributes electrofusion boxes and automatic butt fusion machines and tooling. Fusion also offers an extensive range of spigot fittings. Our products are used in a wide range of applications worldwide, from gas and water infrastructure, to mining, energy and agricultural projects. Our people are valued for their knowledge and experience of polyethylene and their passion to deliver innovation.

World Class Manufacturing

Fusion has extensive manufacturing, test and inspection facilities and have integrated lean principles of continuous improvement within its manufacturing culture.

Fusion is much more than just manufacturing, it has world class facilities which give confidence to an end product which is fully traceable: right down to the core components.

High Standards

With ISO9001 certification and multi-national approvals, both Fusion and AVK believe in much more than just passing the finished product on to the consumer, but to give them the quality assurance they need on all the products supplied to the utilities industry, with relevant AVK companies complying with TS standards.

Our products meet and often exceed, the highest standards of safety and durability as well as being regularly audited by various institutions such as Bureau Veritas, AMI, KIWA, BSI, DVGW, INSTA-CERT and others.



GLOBAL PE PRODUCT OFFER

FOR GAS AND WATER



The global PE product offer brochure for gas and water featuring PE ball and butterfly valves, electrofusion, spigot and transition fittings, access systems and associated equipment and ancillaries.

For the full range visit our website:
www.fusiongroup.com

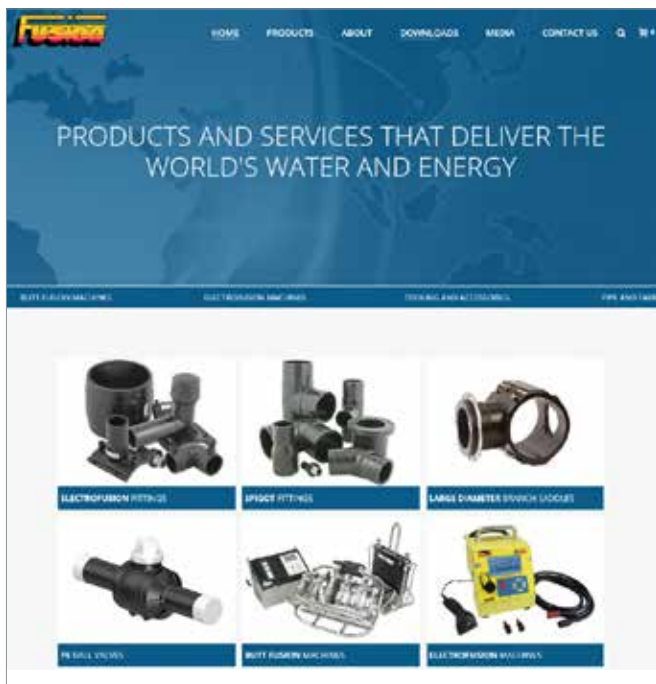

CERTUS™ PE BALL VALVES FOR GAS AND WATER

Body and spigots manufactured from high performance **PE100**. This material can be welded to all PE100 and PE80 pipes.

The spigots are butt welded to the body. **Visual beads** reassuring joint quality for each weld.

Modular design of top cap allowing for customer specific versions and a variety of accessories.

The valves are equipped with a **weather seal** avoiding ingress of ground water and dirt into the operating mechanism.

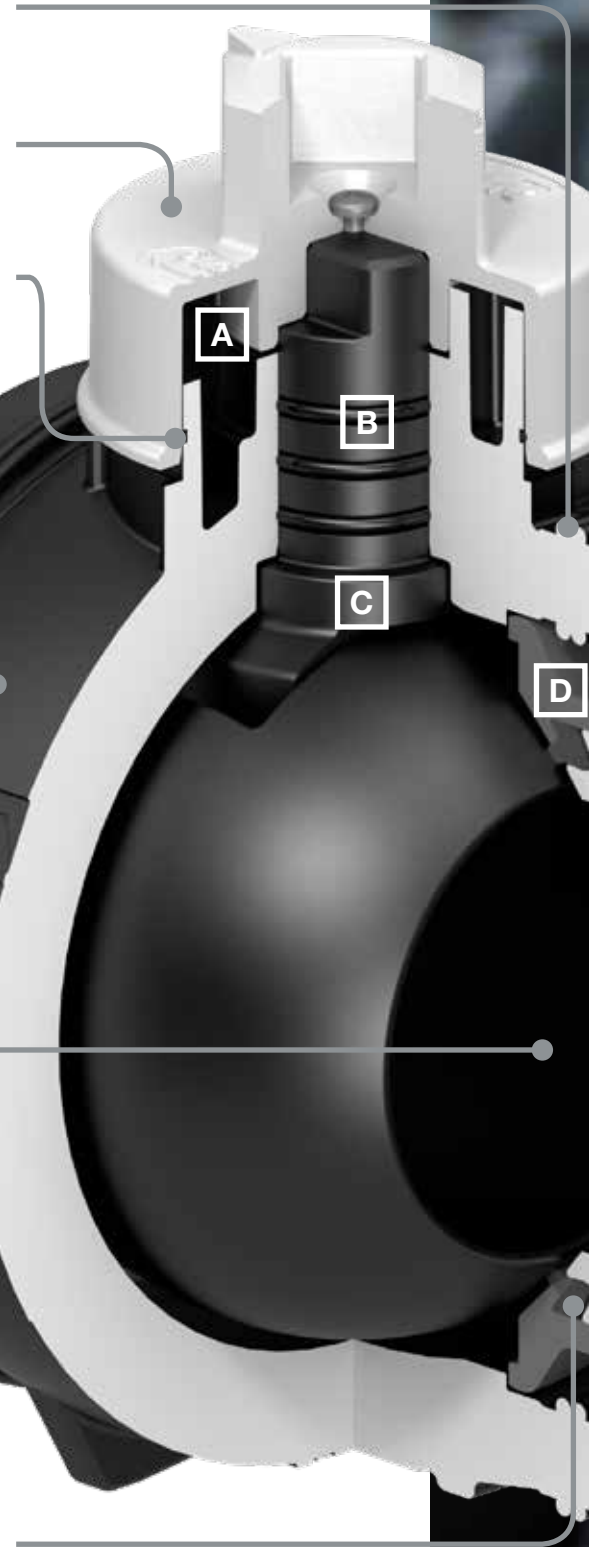

All spigot ends can be delivered with **double spigot length** allowing for a second electrofusion weld if the first one fails.

All **Certus** Series 85/30 valves are designed with a **clearway bore** (sizes d20, 32, 63, 90, 110 and 160mm only) ensuring no additional pressure drop and greater flow through the valve for the same pressure. The clearway bore allows for pigging of pipes.

The **spigot ends are machined** on the inside as well as on the outside, guaranteeing a uniform wall thickness, allowing for optimal welding of electrofusion couplers and the smooth inner surface prevents deposits and will minimise flow resistance.

The floating ball principle and **special shaped ball seats** are designed to ensure sealing at all times and be less affected by dirt or debris.

The **Certus Series 85/30** is an extensive range of PE ball valves up to d180 used for isolation of water and gas service to both domestic and commercial premises.

The Certus PE100 ball valves are manufactured at AVK Syntec, a modern purpose built and well equipped manufacturing facility complying with the international standard ISO/TS 29001:2010 quality management system, uses state of the art machinery and methods to produce high quality products.

Every valve is individually tested and given a unique serial number which can be traced as far back as the raw polyethylene material.

All of the manufacturing processes are managed to the exacting standards of the ISO 9001 certification and ISO/TS 29001:2010.

These robust PE ball valves have been extensively and independently type tested against worldwide leading standards such as GIS/V7: Part 2, EN 1555-4. Full documented records of type testing are maintained by AVK and are available on request.

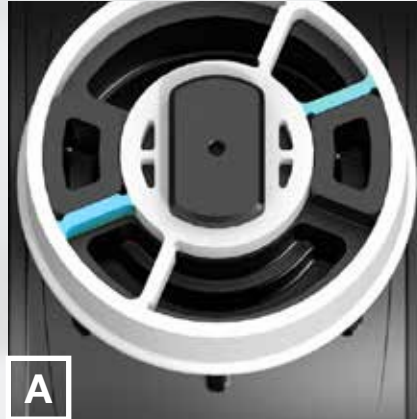

A If the valve is over torqued, the top cap is designed to fail before the valve seals, thus preventing a leak to atmosphere. The **safety top cap** can be replaced easily under live conditions.

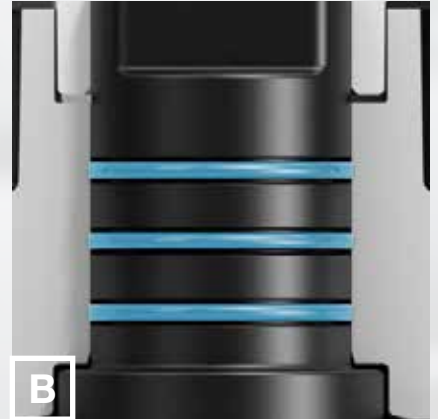

B **Triple O-ring construction** around the stem guaranteeing sealing safety at all times, even during ground movement.

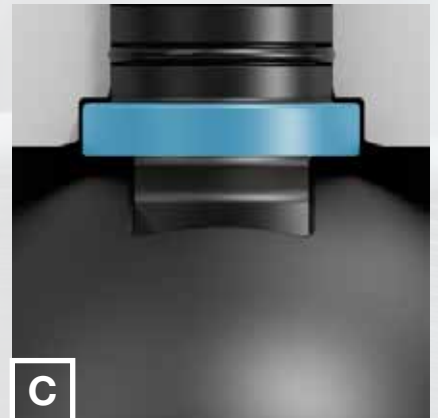

C The intentionally over-designed stem is extremely strong and of the **anti blow-out** type.

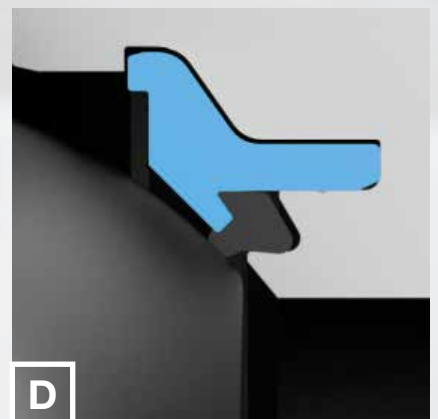

D The **seat retainer** design ensures the ball seat is kept in place at all times. This optimal design prevents the ball seat from being dislodged, which guarantees a good functionality throughout the years.



Certus PE Ball Valves



- PE100
- GIS/V7: Part 2 / EN 1555-4
- MOP dependant on SDR Rating
- Clearway bore - Sizes d20, 32, 63, 90, 110 and 160
- Full bore - Sizes d40, 125 and 180
- d20 - 180

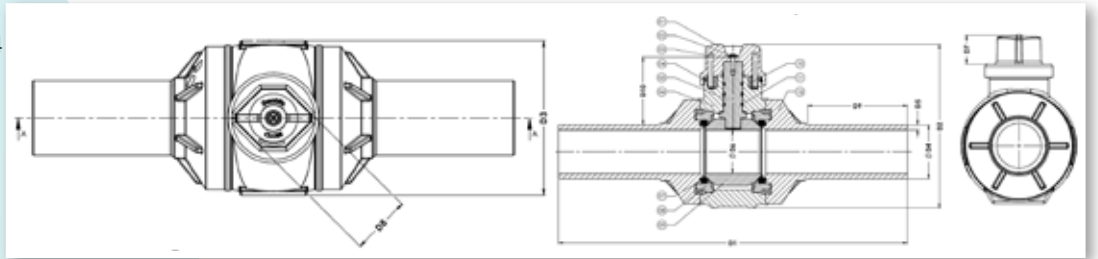

Code	d	D1	D2	D3	D4	D5	D6	D7	D8	D9	Weight	Delivery Code
	mm	mm	mm	mm	mm	mm	mm	mm	mm	mm	Kg	
BV20CER8530N	20	305	145	95	20	3.0	26	33	49.6	82	0.7	A
BV32CER8530N	32	320	145	95	32	3.0	26	33	49.6	88	0.8	A
BV40CER8530N	40	340	145	95	40	3.7	26	33	49.6	98	0.8	A
BV63CER8530N	63	435	195	135	63	5.8	51	33	49.6	130	1.7	A
BV90CER8530N	90	520	285	180	90	8.2	74	46	49.6	158	3.7	A
BV110CER8530N	110	560	280	205	110	10.0	90	31	49.4	164	5.3	A
BV125CER8530N	125	585	280	205	125	11.4	90	31	49.4	182	5.7	A
BV160CER8530N	160	700	370	280	160	14.6	131	35	49.4	196	13.4	A
BV180CER8530N	180	735	370	280	180	16.4	131	35	49.4	220	14.4	A

Certus - Installation Kit



- Installation Kit to suit d20, 32, 40 and 63 Certus Valves
- Available with or without lid

Code	Description	Weight	Delivery Code
		Kg	
CERTUSCHAMBKIT	Installation kit including surface box	2.6	A
CERTUSCHAMBER	Installation kit without surface box	2.3	A

Certus - Square Drive Tee Key



- 50mm Square Drive Tee Key to suit Certus PE Ball Valves
- 750-1500mm

Code	Range	Weight	Delivery Code
	mm	Kg	
CERTUSKEY750MM	750mm long	1.5	A
CERTUSKEY1M	1,000mm long	2.2	A
CERTUSKEY1.5M	1,500mm long	3	A



MAGNUS™ PE BALL VALVES FOR GAS AND WATER

All spigot ends can be delivered with the **double spigot length** option allowing for a second electrofusion weld if the first one fails.

The spigots are butt welded to the body. **Visual beads** reassuring joint quality for each weld in complete pipe line.

The valves are equipped with a **weather seal** avoiding ingress of ground water and dirt into the operating mechanism.

The stem is of the **anti blow-out** type and has a double O-ring seal to guarantee safety at all times.

Body and spigots manufactured from high performance **PE100-RC**. This material is extremely resistant to slow crack propagation and can be welded to all PE100 and PE80 pipes.

All **Magnus** valves are designed with a **full bore** ensuring a reduced pressure drop and greater flow through the valve for the same pressure. The large bore allows for pigging of pipes.

The **spigot ends are machined** on the inside as well as on the outside, guaranteeing a uniform wall thickness, allowing for optimal welding of electrofusion couplers and the smooth inner surface prevents deposits and will minimise flow resistance.

The floating ball principle and **special shaped ball seat** with large sealing surface are designed to ensure sealing at all times and be less affected by dirt or debris that might be in the pipeline.

The **Magnus Series 85/50** is an extensive range of PE ball valves up to d180 used for isolation of water and gas service to both domestic and commercial premises.

The range have been extensively and independently type tested against worldwide leading standards such as EN1555-4, ISO4437-4 and EN12201-4 for water applications.

Magnus ball valves have undergone additional testing over and above that required in the specification. This ensures that the valve is suitable for distribution systems and environments anywhere in the world.

The extensive Magnus ball valve range consists of multiple sizes starting at d25 up to d180. Depending on the requested pressure rating the valves are available with SDR11 or SDR 17 spigot ends. The selected materials are tested and approved for GAS and WATER applications.

When used in GAS applications the valves are rated as MOP10 and PN16 for WATER.

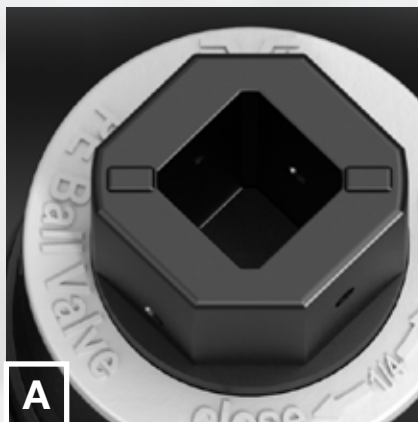

Due to the **internal and external drive** the valves can be operated by all standardised spindles.

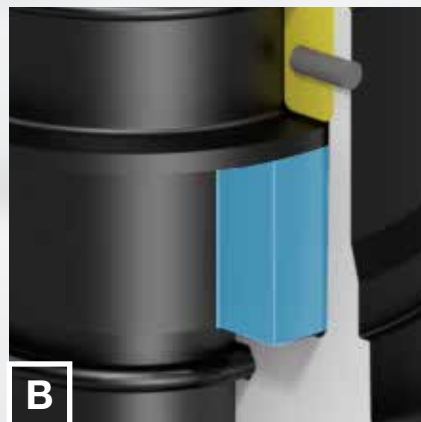

If the valve is over torqued during opening or closing, the connector is designed to fail before the valve seals, thus preventing a leak to atmosphere. The **safety connector** can be replaced under live conditions.

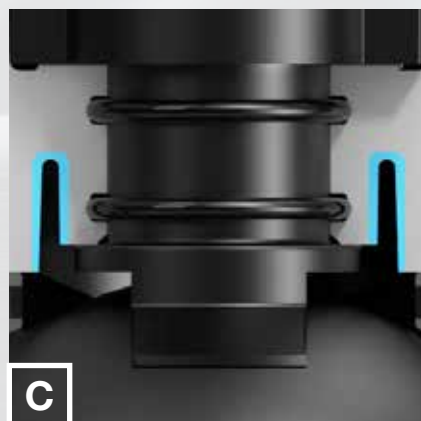

The **flexible spindle shaft** ensures equal compression around the O-rings when loaded by internal pressure. At the same time the groove will adapt to any deformation as a result of upstream pressure on the ball when the valve is in the closed position.

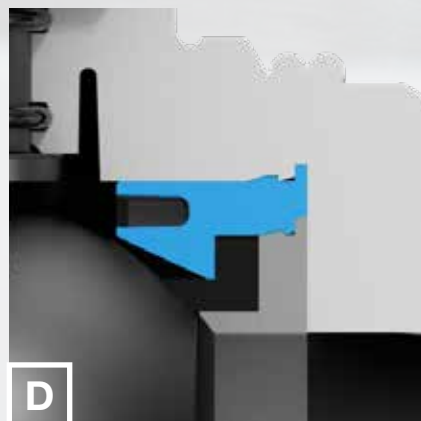

The **seat retainer and support ring** design ensure the ball seat is kept in place at all times. This optimal design prevents the ball seat from being dislodged, which guarantees a good functionality throughout the years.





Magnus Full Bore PE Ball Valves



- PE100
- EN12201-4 / EN 1555-4
- Full Bore
- d25-180

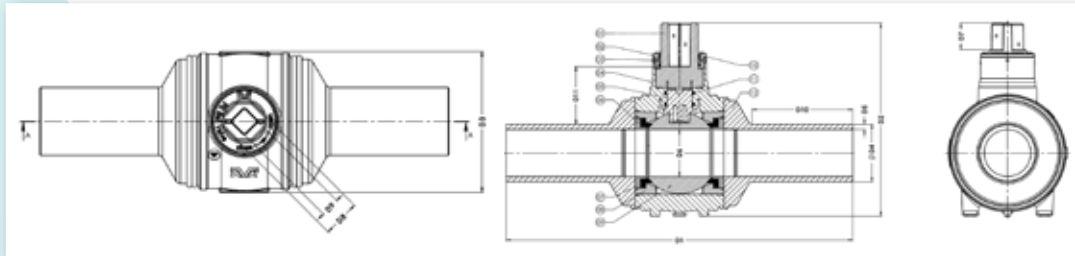

Code	D4 mm	D6 mm	D1 mm	D2 mm	D3 mm	D5 mm	D7 mm	D8 mm	D9 mm	D10 mm	D11 mm	Weight Kg	Delivery Code
BV25MAG8550N	25	25	310	190	90	3	35	49.6	20.5	84	65	0.9	B
BV32MAG8550N	32	25	320	190	90	3	35	49.6	20.5	90	62	0.9	B
BV40MAG8550N	40	32	340	205	100	3.7	35	49.6	20.5	98	65	1.1	B
BV50MAG8550N	50	40	365	220	115	4.6	35	49.6	20.5	111	65	1.4	B
BV63MAG8550N	63	50	440	255	140	5.8	40	49.6	25.5	128	80	2.5	B
BV90MAG8550N	90	74	545	300	185	8.2	40	49.6	25.5	158	90	5	B
BV110MAG8550N	110	86	585	320	205	10	40	49.6	25.5	165	90	6.7	B
BV125MAG8550N	125	86	595	320	205	11.4	40	49.6	25.5	176	80	7.2	B
BV160MAG8550N	160	120	710	405	285	14.6	40	49.6	25.5	196	105	16.3	B
BV180MAG8550N	180	120	725	405	285	16.4	40	49.6	25.5	210	65	17.3	B

Magnus Full Bore PE Ball Valve with Lever



- PE100
- EN12201-4 / EN 1555-4
- d25-180

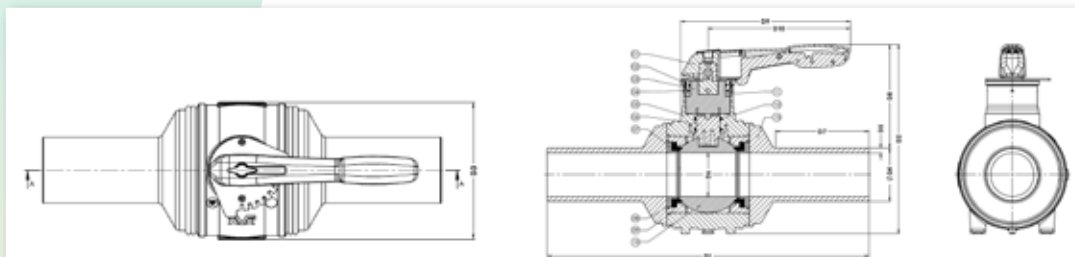

Code	D4 mm	D6 mm	D1 mm	D2 mm	D3 mm	D5 mm	D7 mm	D8 mm	D9 mm	D10 mm	Weight Kg	Delivery Code
BV25MAG8550NL	25	25	310	190	90	3	54	140	230	195	1.3	A
BV32MAG8550NL	32	25	320	190	90	3	90	140	230	195	1.3	A
BV40MAG8550NL	40	32	340	205	100	3.7	98	140	230	195	1.4	A
BV50MAG8550NL	50	40	365	220	115	4.6	111	145	230	195	1.7	A
BV63MAG8550NL	63	50	440	255	140	5.8	130	165	286	240	3.1	A
BV90MAG8550NL	90	74	545	300	185	8.2	158	175	286	240	5.4	A
BV110MAG8550NL	110	86	585	320	205	10	165	170	286	240	7.4	A
BV125MAG8550NL	125	86	595	320	205	11.4	176	165	286	240	7.8	A
BV160MAG8550NL	160	120	710	405	285	14.6	196	210	450	390	17.4	A
BV180MAG8550NL	180	120	725	405	285	16.4	210	205	450	390	18.5	A



Magnus Full Bore PE Ball Valve with Stem Extension



- PE100
- EN12201-4 / EN 1555-4
- d63-180

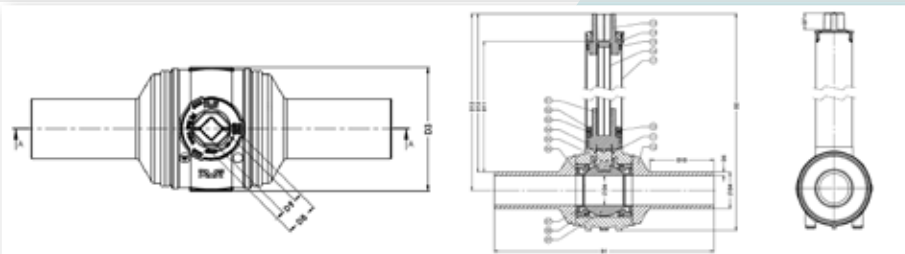

Code	D4	D6	D1	D2	D3	D5	D7	D8	D9	D10	D11	D12	D13	Weight	Delivery Code
	mm	mm	mm	mm	mm	mm	mm	mm	mm	mm	mm	mm	mm	Kg	
BV63MAG8550NS	63	50	440	810	140	5.8	40	49.6	25.5	130	635	700	730	3.9	B
BV90MAG8550NS	90	74	545	855	185	8.2	40	49.6	25.5	158	645	710	755	6.4	B
BV110MAG8550NS	110	86	585	875	205	10	40	49.6	25.5	165	645	710	765	8.2	B
BV125MAG8550NS	125	86	595	875	205	11.4	40	49.6	25.5	176	635	705	765	8.6	B
BV160MAG8550NS	160	120	710	1045	285	14.6	40	49.6	25.5	196	750	815	895	18.4	B
BV180MAG8550NS	180	120	725	1045	285	16.4	40	49.6	25.5	210	740	805	895	19.4	B

Magnus Full Bore PE Ball Valve with Stem Extension and 1 Purge Point



- PE100
- EN12201-4 / EN 1555-4
- d63-180

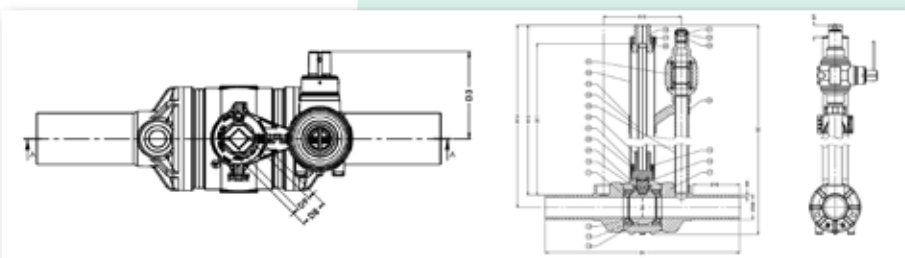

Code	D4	D6	D1	D2	D3	D5	D7	D8	D9	D10	D11	D12	D13	D14	Weight	Delivery Code
	mm	mm	mm	mm	mm	mm	mm	mm	mm	mm	mm	mm	mm	mm	Kg	
BV63MAG8550NSP	63	50	715	810	152	5.8	40	49.6	25.5	170	635	285	700	730	6.8	B
BV90MAG8550NSP	90	74	710	855	152	8.2	40	49.6	25.5	170	645	285	710	755	10.1	B
BV110MAG8550NSP	110	86	715	875	152	10	40	49.6	25.5	170	645	285	710	765	11.9	B
BV125MAG8550NSP	125	86	715	875	152	11.4	40	49.6	25.5	170	635	285	700	765	12.6	B
BV160MAG8550NSP	160	120	795	1045	152	14.6	40	49.6	25.5	170	750	355	815	895	24.3	B
BV180MAG8550NSP	180	120	795	1045	152	16.4	40	49.6	25.5	170	740	355	805	895	26.2	B

Magnus Full Bore PE Ball Valve with Stem Extension and 2 Purge Points



- PE100
- EN 1555-4
- d63-180

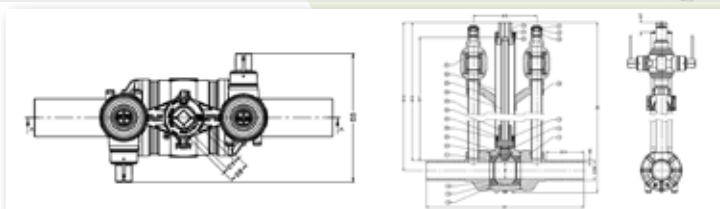

Code	D4	D6	D1	D2	D3	D5	D7	D8	D9	D10	D11	D12	D13	D14	Weight	Delivery Code
	mm	mm	mm	mm	mm	mm	mm	mm	mm	mm	mm	mm	mm	mm	Kg	
BV63MAG8550N2P	63	50	715	810	305	5.8	40	49.6	25.5	170	635	285	700	730	8.7	B
BV90MAG8550N2P	90	74	710	855	305	8.2	40	49.6	25.5	170	645	285	710	755	12	B
BV110MAG8550N2P	110	86	715	875	305	10	40	49.6	25.5	170	645	285	710	765	13.8	B
BV125MAG8550N2P	125	86	715	875	305	11.4	40	49.6	25.5	170	635	285	700	765	14.6	B
BV160MAG8550N2P	160	120	795	1045	305	14.6	40	49.6	25.5	170	750	355	815	895	26.3	B
BV180MAG8550N2P	180	120	795	1045	305	16.4	40	49.6	25.5	170	740	355	805	895	27.1	B

TIMESAVER™ PE BUTTERFLY VALVES FOR GAS AND WATER



FUSIBLE BUTTERFLY VALVE

Series 89 fusible butterfly valves are designed for butt-fusion or electrofusion into HDPE piping systems. The Series 89 leak-free system enables ease of installation and eliminates the need for flange adaptors, spacers, backing rings, nuts, bolts or gaskets.



WAFER BUTTERFLY VALVE

The Series 891 wafer butterfly valve utilises existing flanges, eliminating the need for valve spacers. The wafer valve is preferred in applications where easy access into piping systems is needed.



FUSIBLE DUAL CONTAINMENT BUTTERFLY VALVE

Series 890, dual-containment butterfly valves include a second pipe housing. This unit can be fused into new or existing dual-containment (double wall) HDPE pipelines, eliminating the need for valve boxes or vaults.

The Series 89 Timesaver butterfly valves are designed for quick, direct heat butt fusion or electrofusion into HDPE piping systems up to d315 (DN300). The Series 89 leak-free system enables ease of installation and eliminates the need for flange adaptors, spacers, backing rings, nuts, bolts or gaskets.

360° incremental positioning lever standard for d63-180 (DN50 - 150); gearboxes standard on d200 and above

Stem extensions available from d300 to 2700mm, in 150mm increments

Phenolic seat ring with bonded NBR on butterfly, **dual-containment** and wafer valves

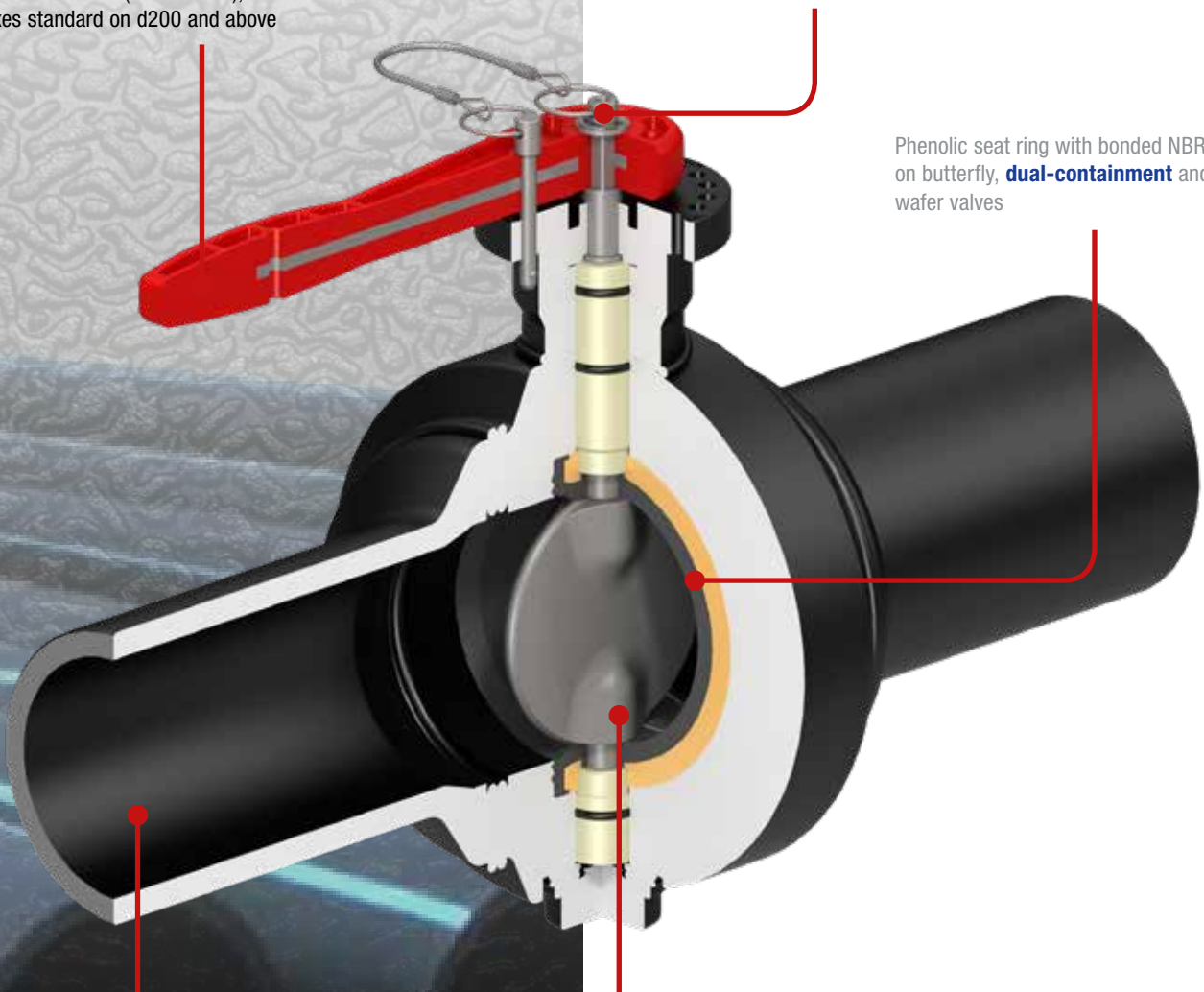

The Timesaver Series 89 valves (excluding the wafer valve) are **designed for butt-fusion or electrofusion into HDPE piping systems**. The Series 89 leak-free system enables ease of installation and eliminates the need for flange adaptors, spacers, backing rings, nuts, bolts or gaskets.

ASTM A582 316 stainless steel stems and discs on butterfly, dual-containment and wafer valves

IPS valve sizes range from **d63 - 315 (DN50 through 300)** with larger sizes and DIPS available upon request

Timesaver Butterfly Valve



Series 89/BFV
 HDPE Fusible End
 Butterfly Valve
 SDR 11 (Standard)
 PE100

Stainless Steel Disc
 NBR Seat
 d63 - 315 (DN50-300)
 DN350 - 600 available upon request
 DIPS available upon request

Levers standard on sizes DN50-150
 Gearboxes standard on sizes DN200-300
 Gearboxes available on DN50-150 sizes
 upon request
 Stem extensions available upon request
 (150mm increments)

Code	d	DN	PN	Weight	Delivery Code
	mm	mm	Bar	Kg	
89-050-50003	63	50	10	2	C
89-080-50003	90	80	10	5	C
89-100-50003	125 / 110	100	10	7	C
89-150-50003	160 / 180	150	10	11	C
89-200-50003	200 / 225	200	10	36	C
89-250-50003	250 / 280	250	10	48	C
89-300-50003	315	300	10	66	C

Timesaver Dual Containment Butterfly Valve



Series 890/DCV
 HDPE Fusible End
 Dual Containment
 Butterfly Valve
 SDR 11 (Standard)
 PE 100

Stainless Steel Disc,
 NBR Seat
 d63-110/125 - 160-180/250-280
 (DN50x100 through 150x250)
 200x300 available upon request
 DIPS available upon request

Levers standard on sizes DN50-150
 Gearboxes standard on sizes DN200-300
 Gearboxes available on DN50-150 sizes
 upon request
 Stem extensions available upon request
 (150mm increments)

Code	d	DN	PN	Weight	Delivery Code
	mm	mm	Bar	Kg	
890-050-50003	63-110/125	50x100	10	3	C
890-080-50003	90-160/180	80x150	10	7	C
890-100-50003	110-125/200/225	100x200	10	14	C
890-150-50003	160-180/250-280	150x250	10	20	C

Timesaver Wafer Butterfly Valve



Series 891/WAF
 HDPE Wafer
 Butterfly Valve
 Bolting pattern to
 ASME/ANSI B 16.1
 Class 125

PE 100
 Stainless Steel Disc,
 NBR Seat
 d63 - 315 (DN50-300)
 DN350-450 available upon request

Levers standard on sizes DN50-150
 Gearboxes standard on sizes DN200-300
 Gearboxes available on DN50-150 sizes
 upon request
 Stem extensions available upon request
 (150mm increments)

Code	d	DN	PN	Weight	Delivery Code
	mm	mm	Bar	Kg	
891-050-50003	63	50	10	3	C
891-080-50003	90	80	10	6	C
891-100-50003	125 / 110	100	10	9	C
891-150-50003	160 / 180	150	10	22	C
891-200-50003	200 / 225	200	10	6	C
891-250-50003	250 / 280	250	10	9	C
891-300-50003	315	300	10	22	C



FUSAMATIC™ ELECTROFUSION FITTINGS FOR GAS AND WATER



Fusion Group's **Fusamatic** division is a world leader in the manufacture of electrofusion fittings.

All Fusion's electrofusion fittings are individually inspected using a computerised monitoring system that utilises advanced barcode technology. The barcode provides full individual fitting traceability right down to the polymer batch. The production quality, reliability and flexibility of Fusion's electrofusion fittings provides the certainty and peace of mind needed for polyethylene pipe jointing.

Together, electrofusion fittings and polyethylene pipes enable utilities, designers and contractors to create fully welded pipe networks. The production quality, reliability, and flexibility of Fusion's electrofusion fittings buys you peace of mind and certainty.

Sizes

Sizes range from d20 to 630+, d710 to 1200 available on request

Pressure Ratings

All fittings are manufactured in virgin PE100 black polyethylene and pressure rated up to 10 bar for gas applications and 16 bar for water applications.

NOTE: For UK gas applications (GIS PL2 Part 4) the maximum operating pressure can be either 5.5 bar or 7 bar dependant on the Class rating. For more detailed information contact us.

SDR Ratings

The appropriate pipe SDR rating for electrofusion fittings is in accordance with the list below:

FITTING SIZES BELOW 63mm - Pipe SDR11

- Coupler
- Elbow
- Reducer
- Equal tee
- Tapping tee
- Branch saddle
- Transition fittings

FITTING SIZES 63mm AND ABOVE - Pipe SDR11 to 17.6

- Coupler
- Elbow
- Reducer
- Equal tee
- Tapping tee*
- Branch saddle
- Hydrant products
- Transition fittings

* Tapping tees for 63mm mains only are not suitable for SDR17 pressurised pipe applications.

Testing can be carried out on SDR rated pipe outside the stated ranges if required. Please contact Fusion's sales team on +44 (0)1246 268666 for details.

Testing

Fusamatic fittings are tested, accredited and approved against many international performance standards including:

- Kitemark GIS/PL2-4
- Kitemark GIS/PL2-6
- AS/NZS 4129, Watermark and ISO Type 5 Licence
- EN 1555-3
- UNI EN 1555-3
- INSTA SBC EN 1555-3
- EN 12201-3
- UNI EN 12201-3
- INSTA SBC EN 12201-3
- EN ISO 15494
- UNI EN ISO 15494
- WRAS
- ACS
- DVGW GW 335-B2-B1
- KIWA BRL-K17105

FUSAMATIC

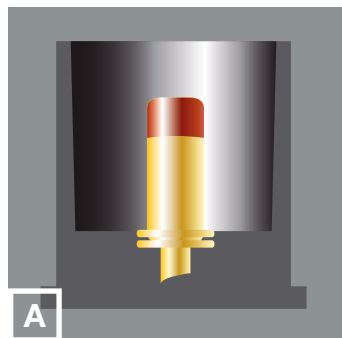

Fusamatic Pin

Invented by Fusion, the Fusamatic pin provides a totally automatic method for ensuring the correct welding parameters are used. Within each Fusamatic pin is a resistor. When the electrofusion box is connected to the fitting, the Fusamatic pin enables it to automatically identify the correct fusion time required to make the joint. All the operator has to do is press go!



Indicators

The pressure, created by the expanding molten plastic in the jointing area inside the fitting during the electrofusion process, will force out the indicator lugs. This is a visible sign that the necessary jointing pressure has been achieved.



Moulded-in welding parameters

Manual welding parameters are moulded into the body of all Fusion's fittings. Information provided includes fitting size, material (PE100), applicable pipe SDRs, weld parameters, and pressure ratings for gas and water applications.



Permanently marked batch number

The injection moulded batch number is just one of numerous quality control identifiers on each Fusamatic fitting. It is replicated on the fitting's barcode.



Barcode / QR Code

Quality control is central to the success of Fusion's fittings. The unique barcode configuration, including QR code provides full traceability of raw material for each individual fitting as well as providing welding information when used in conjunction with electrofusion boxes equipped with a barcode scanner.

FUSAMATIC™ LOW PRESSURE ELECTROFUSION COUPLER FOR WATER



Introducing a range of low pressure couplers specifically developed for thin walled pipe in SDR17-26.

Designed for low pressure water applications; irrigation, waste-water, sewage and drainage.

Sizes

Sizes range from d110 - 400mm.

Pressure ratings

All low pressure electrofusion fittings are manufactured in PE100 black polyethylene and pressure rated up to 10 bar for water applications.

SDR ratings

Specifically developed for thin walled pipe SDR17 - 26.

Specifications

All low pressure couplers are tested, accredited and approved against the following standards;

- EN12201-3
- UNI EN 12201-3
- AS/NZS 4129
- Watermark
- ISO Type 5 licence

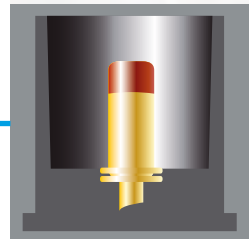

Fusamatic Pin *

Invented by Fusion, the Fusamatic pin provides a totally automatic method for ensuring the correct welding parameters are used. Within each Fusamatic pin is a resistor. When the electrofusion box is connected to the fitting, the Fusamatic pin enables it to automatically identify the correct fusion time required to make the joint. All the operator has to do is press go!

*Fusamatic pin available on sizes 110mm - 250mm



Moulded-in welding parameters

Manual welding parameters are moulded into the body of all Fusion's fittings. Information provided includes fitting size, material (PE100), applicable pipe SDRs, weld parameters, and pressure ratings for gas and water applications.



Barcode

Quality control is central to the success of Fusion's fittings. The unique barcode configuration, including QR code, provides full traceability of raw material for each individual fitting as well as providing welding information when used in conjunction with electrofusion boxes equipped with a barcode scanner.

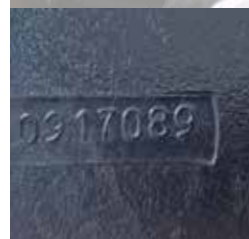

Permanently marked batch number

The injection moulded batch number is just one of numerous quality control identifiers on each Fusamatic fitting. It is replicated on the fitting's barcode.



Indicators

The pressure, created by the expanding molten plastic in the jointing area inside the fitting during the electrofusion process, will force out the indicator lugs. This is a visible sign that the necessary jointing pressure has been achieved.

FUSAMATIC™ MULTISEAL TAPPING TEE FOR GAS AND WATER



Security – LockCap
Multiseal has a tamper-proof LockCap which ensures correct installation – it cannot be over-tightened – and won't vibrate loose.

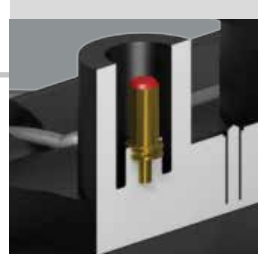

Fusamatic Pin
Invented by Fusion, the Fusamatic pin provides a totally automatic method for ensuring the correct welding parameters are used. Within each Fusamatic pin is a resistor. When the electrofusion box is connected to the fitting, the Fusamatic pin enables it to automatically identify the correct fusion time required to make the joint. All the operator has to do is press go!



Safety – O-ring Seals
Multiseal tapping tees incorporate two O-ring seals; an internal O-ring in the body of the fitting which seals on the cutter, and an external O-ring which seals against the tightened LockCap. Together these seals protect against leakage, and in conjunction with the optional cutter tube, deliver quality live connections.



Optional Cutter Tube
Optional cutter tube delivers quality live connections. The cutter tube locks into the integral cutter which allows for leak free cut through of the mains pipe. Important for live or medium pressure applications. The tube must be specified at the time of order, simply add 'T' to the fitting code e.g. MTBKHA63X32T

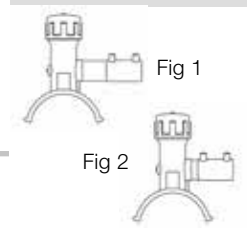

Second Chance – Double Spigot Outlet
The outlet spigot on Multiseal Tapping Tees gives the installer a 'second chance' – if problems occur with the initial service connection (Fig 1) there is sufficient spigot length to cut off the coupler and fuse a second fitting (Fig 2).



Simplicity – Stackload or Underclamp
Installers can buy Multiseal as a standard stackloading tee, or opt for the sacrificial toggle-clamp underpart. The toggle-clamp design snaps quickly in place, saves the installer time, avoids the need for specialist tooling, and provides proof of clamping during the fusion cycle.

Multiseal tapping tees deliver security, safety, simplicity and speed at the point of installation.

Sizes
Sizes range from d40 – 355mm with 20, 25, 32, 40, 50 and 63mm outlets

Pressure ratings
All Multiseal tapping tees are manufactured in PE100 black polyethylene and pressure rated up to 16 bar for water applications and 10 bar for gas applications (for UK gas applications (GIS PL2 Part 4) the maximum operating pressure can be up to 5.5 bar (Class B) or 7 bar (Class C)).

- Features and benefits**
- Multiseal saddle and fusion mat have been designed to minimise joint cycle times.
 - Thread profile on the Multiseal's internal cutting mechanism reduces the level of torque required to drive the cutter through the body of the main.
 - Corrosion resistant brass terminal pins.
 - Cutter blades manufactured from corrosion resistant stainless steel.



Quality control is central to the success of Fusion's fittings. The unique barcode configuration, including QR code, provides full traceability of raw material for each individual fitting as well as providing welding information when used in conjunction with electrofusion boxes equipped with a barcode scanner.

THE GOOD GUIDE TO ELECTROFUSION JOINTING



This guide will provide basic information to enable the operative to:

- Understand the principles of electrofusion jointing.
- Carry out pre-jointing equipment checks.
- Identify pipe and compatible fittings.
- Inspect for, and identify acceptable quality joints.
- Make satisfactory electrofusion joints from compatible pipes and fittings.
- Site the equipment.

Safety Notice

To ensure operator safety and comply with Health and Safety regulations all electrofusion control boxes must be operated from an effectively earthed supply in accordance with the manufacturers' operating instructions.

Equipment required:



Generator of suitable size to power control box - refer to manufacturers' literature for power requirements



Welding tent/shelter and ground sheet



Indelible marker pen



Electrofusion control box with appropriate leads



Re-rounding clamp if pipe has become oval or has a flat spot



Restraining and alignment equipment



Scraping equipment



Pipe cutter



Multiseal test cap



Principles

Electrofusion is a method of joining PE pipes using fittings with integral heating elements. Sockets are used to join mains and service pipes and saddle fittings are used to connect services to mains.

The term “socket” covers couplers, elbows, reducers etc.

The term “saddle” covers branch saddles and tapping tees.

The pipe to be joined must be prepared by removing the outer surface layer to a depth of around 0.2mm, then pipe and fitting are clamped together to prevent movement. A voltage is applied across the fitting terminals via a control box.

An electric current is passed through the wire which heats the wire and melts the polymer, fusing the fitting to the pipe. After welding, the joint is allowed to cool before removing the restraining clamps.

Pipe/Fitting Selection



Check that both pipe(s) and fitting to be joined are compatible, only compatible materials should be joined together. Check PN and SDR rating marked on fitting and compare with that of the pipe. If in doubt, seek advice from the pipe or fitting manufacturer.

Fusamatic fittings are suitable for jointing in ambient temperatures between -10°C and +40°C and do not require any form of pre-heat or temperature compensation. For jointing outside these temperatures guidance should be sought from the manufacturer.

Siting Equipment

Wherever possible, the electrofusion equipment should be placed on a suitable clean, dry base board or ground sheet inside a tent/shelter to minimise contamination.



Ensure that the area where the weld is to be carried out has any surface water removed and that some form of groundsheet is used to isolate the jointing area from the trench floor.

THE GOOD GUIDE TO ELECTROFUSION SOCKET JOINTING

Pre-Jointing Checks

- Accept only equipment which has been regularly serviced and is in good condition.
- Check that clamps and liners are correct and are clean. Advice on appropriate clamps and scrapers is available from all fitting manufacturers.
- Check that the scrapers are clean and the blade is not damaged and is in good condition.
- Check that the fitting is still in its original packaging and that the bag is not damaged or contains any condensation or dust.

Pipe preparation - controlling ovality

- Ovality in PE pipe can occur as a result of coiling, storage and transportation.
- Fusamatic Electrofusion fittings have been designed to allow for a small degree of ovality (1 – 2%), but excessive gaps should be avoided by using alignment clamps with a re-rounding ability.
- In order to correct the effects of pipe ovality prior to the electrofusion process it is recommended that re-rounding clamps and/or tools be used as appropriate. This is particularly important where coiled or thin walled pipe is being used as ovality in these cases can be extreme.
- Use the appropriate re-rounding clamp as per manufacturers' instructions.

SOCKETS JOINT ASSEMBLY PREPARATION

1. Check that the pipe ends are cut square and are free from surface damage and swarf.

2. Wipe loose dirt from the area of pipe to be clamped and fused with a prescribed wipe, damp cloth or paper towel. (Wipe any contaminates from the inside of the pipe).



3. Mark the insertion depth on the pipe by holding the bagged fitting against the pipe.



4. Cross hatch the area to be scraped plus an additional 20-50mm using the indelible marker pen.



5. Scrape one pipe end using a prescribed tool, for the length of the insertion depth plus 10-20mm. Ensure the whole surface area has been scraped.



6. For skinned pipe use the manufacturers' recommended tools to remove the skin. Some skinned pipe still requires a scraping operation but advice from the pipe manufacturer should be sought before preparing to join the pipe.

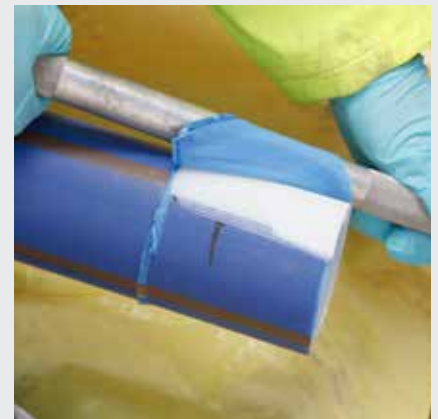

7. Open fitting bag, check the fitting is clean and immediately place over pipe end and push up to centre stops, or for fittings without centre stops insert the pipe to half the overall fitting length (mark this distance on the pipe prior to insertion). Leave bag over fitting for temporary protection.



8. Prepare the second pipe in the same way as the first, as previously described.

9. Remove the bag and push the second pipe into the fitting. Mark the penetration depth on the pipe and tighten the restraining clamp.

10. Check fitting penetration - using previously marked lines on pipe. Visually check pipe alignment in all planes. Rotate the fitting to ensure no excessive forces are present.



N.B. Spigot fittings i.e. saddle outlets, spigot outlet on tees, stub flanges should be scraped and restrained as with pipes.

Important Note: It is imperative that both the pipe and fitting jointing surfaces are kept clean and dry during the assembly and welding process. This is best achieved by preparing the pipe and then immediately assembling.

In certain circumstances it is accepted procedure to use alcohol wipes to clean any contamination from the joint surfaces, however we recommend that this practice be only used where absolutely necessary.

Making the weld

1. Check generator has sufficient fuel.

2. Start the generator and then plug the control box input lead into the generator output socket. Connect the control box output leads to the fitting terminals - if automatic fittings and control box are being used, connect the red lead to the fitting terminal with the red pin, connect black lead to plain pin.



3. Check that the weld time marked on the fitting is displayed on the control box display. For manual fittings, check the weld time marked on the fitting and enter this figure into the control box. For 'barcode' fittings weld parameters are selected by scanning the barcode with the barcode scanner.

4. Respond to prompts from the box. Press 'START' and hold down until display begins countdown. The weld cycle is complete when the timer reaches zero and the control box 'CYCLE FINISH' indicator shows.



5. Allow weld to cool for the full time stated on fitting before removing clamps and moving the assembly.

Quality Checks

- Check for any error messages on the control box.
- Check fusion indicators have risen on both sides of the fitting.
- Check for signs of melt exudation from the ends of the fitting.
- Check that the pipe has not moved by looking at the insertion depth marks.

THE GOOD GUIDE TO ELECTROFUSION SADDLE JOINTING

ADDITIONAL EQUIPMENT REQUIRED:

- 12mm cutter key (min length 150mm) and drive
- For stackload versions an appropriate clamp will be required
- For underclamp saddles (other than Multiseal) an appropriate sized socket will be required

SADDLE JOINT ASSEMBLY PREPARATION

1. Expose pipe to which saddle is to be welded ensuring the pipe has no inclusions or gouges in the area where the fitting is to be fused.
2. Ensure enough clearance has been provided (in a trench environment) to carry out the installation.
3. Remove loose dirt from the pipe using a prescribed wipe, damp cloth or paper towel and ensure any risk of contamination from trench wall is minimized.
4. With the fitting still in its protective bag, place over required position on pipe. Mark pipe surface 10mm clear all around contact area and cross hatch the area using a marker pen.



5. Scrape the marked area, ensuring that each stroke of the scraper overlaps the preceding one, keeping hand clear of the scraped surface at all times.



6. For skinned pipe use the manufacturers' recommended tools to remove the skin. Some skinned pipe still requires a scraping operation but advice from the pipe manufacturer should be sought prior to commencement of the installation.

7. Immediately after pipe preparation remove fitting from bag and attach to pipe using suitable clamping equipment.



N.B. For Stackload fittings always bring the clamp to the located fitting, do not slide the fitting under the clamp.

Important Note: Do not touch either prepared pipe surface or the electrofusion surface of the saddle.

Making the weld

1. Follow the same procedure as per socket jointing.
2. Allow weld to cool for the full time stated on fitting before removing stack load clamp or carrying out any cutting or pressure testing operations.



Quality Checks

- Check for any error messages on the control box
- Check fusion indicator has risen on the fitting (saddle fittings only usually have one indicator).
- Check for signs of melt exudation around the saddle base.
- Check that the fitting is square to the main.

SADDLE OUTLET JOINT ASSEMBLY PREPARATION

1. Scrape outlet of tapping tee and service pipe following the procedure described previously for sockets, using an appropriate mechanical scraper



2. Align service pipe and fittings with restraining clamp and make the weld as before.



3. Carry out quality checks as detailed previously

PRESSURE TESTING OF JOINT

- Once the tapping tee has been fused to the pipe and connected to the service pipe, a pressure test can be carried out using a test cap in accordance with the appropriate industry guidelines. Please note it is not possible to use a universal test cap on a Multiseal Tapping Tee
- It is recommended that a pressure no greater than 1.5x the working pressure be used to test the joint integrity.

QUALITY CHECKS

- Check fusion indicator has risen on the fitting.
- Check that no melted material or wire has extruded from the fitting.
- Check for cleanliness around joint area.
- Check for evidence of scraping.

FAILURE OF PRESSURE TEST AND QUALITY CHECK

If the weld fails any of the above checks then:

- a) for sockets - cut out the joint and replace.
- b) for saddles - do not tap the main and cut off the stack so it cannot be used. Carry out a repeat weld using a new fitting at least one pipe diameter away from the failed joint (this may differ depending on utility requirements).

CUTTING THROUGH MAIN

The Multiseal Tapping Tee offers two cutting options for 'dead' and 'live' mains situations:

OPTION 1 - DEAD OR LOW PRESSURE

1. Unscrew cap and insert cutter key into integral cutter.
2. Turn the cutter key clockwise until the cutter has cut through the main.



3. Retract cutter until top is flush with stack and refit cap.

*** Note: with this option a small amount of leakage will occur until the cutter is fully retracted.**

OPTION 2 - LIVE OR MEDIUM PRESSURE

1. Retract the cutter until its top surface is level with the top of the tapping tee stack.
2. Insert the tube into the cutter by pushing and twisting around 1/4 of a turn. There should be no gap between the cutter and the step on the tube.
3. Insert the 12mm cutter key ensuring it is located at the bottom of the cutter drive.



4. Turn the cutter key clockwise until the cutter has cut through the wall of the main, then retract the cutter until top of the cutter is level with the top of the tapping tee stack.

DO NOT REMOVE THE CUTTER KEY FROM THE TUBE UNTIL THE CUTTER HAS FULLY RETRACTED.

Once the cutter is in the fully retracted position, remove the cutter key and then remove the tube. The cap can then be hand tightened on the tapping tee. Please note that once the cap has been fully tightened down it cannot be removed.

THE GOOD GUIDE TO ELECTROFUSION JOINTING



ELECTROFUSION DO'S

- Use a shelter and ground sheet in wet or dry conditions.
- Always use equipment that has been regularly maintained and calibrated.
- Ensure control box voltage compatible with fitting.
- Always use alignment/restraining clamps.
- Cut pipe ends square for electrofusion sockets.
- Scrape pipe and/or spigot surfaces fully.
- Keep scraped pipe and/or spigot surfaces and fittings clean.
- Ensure correct fusion and cooling times are adhered to.
- Assemble joint and fuse immediately after scraping pipe.
- Carry out quality checks before cutting through pipe.
- Mark the fused fitting with the joint number for traceability.

ELECTROFUSION DONT'S

- Do not start the joining process unless it can be completed in one go.
- Leave fittings out of protective bags.
- Use dirty fittings.
- Touch prepared pipe surfaces or fusion areas.
- Allow assemblies to get damp prior to joining.
- Touch fusion indicators during the welding cycle.
- Remove joint from clamps until the full cooling time has elapsed.
- Remove integral cutter from the saddle once the main has been drilled.
- Do not use control box in a trench with gaseous atmosphere.
- On no account should a fitting be fused for a second time.
- Failed joints should not be used. Cut out failed joint and fuse another fitting to the required specification on distance from failed fitting.
- Electrofusion joints should not be carried out on slotted or drilled pipe sections, only solid walled pipe sections.

SAFETY NOTES

Although we make every effort in the design of our products to ensure operator safety, please remember the following precautions:

- Never allow molten or semi-molten polyethylene to come into contact with the skin. However, if this does happen, flush the affected area with cold water and seek expert medical advice.

DO NOT UNDER ANY CIRCUMSTANCE ATTEMPT TO PULL THE MATERIAL FROM THE SKIN AS THIS COULD REMOVE THE SKIN AS WELL.

- Do not attempt to lift long lengths of pipe without assistance or mechanical aid.
- Normal precautions should be observed when handling electrical equipment although, for safety reasons, all 110v portable generator sets should be "Centre Tapped" for site use +55/0/-55 volts.
- To afford protection during jointing, it is advisable to wear protective workwear such as gloves, safety glasses and safety boots.
- Ensure that equipment is serviced on a regular basis as recommended by the equipment manufacturer.

ADDITIONAL INFORMATION STANDARD DIMENSION RATIO (SDR)

The SDR is calculated by dividing the minimum (nominal) outside diameter (OD) by the minimum wall thickness (WT) i.e.

SDR =	OD	125	
	WT	11.4	= 11

From 25mm PE pipe and above the ratio between the outside diameter and the wall thickness remains constant for specific pressure ratings of the pipe.

TRANSITION FROM PE PIPE TO OTHER PIPE AND FITTINGS

Various transition fittings are available to connect to metallic valves, hydrants and pipework. One common method is the use of PE flanges.

It is important to follow manufacturers' recommendations for tightening the necessary bolts. Bolt torque details are supplied with the flanges. It is also important to support any equipment independently of all PE pipework (ie. valves to be mounted on concrete blocks).

PRODUCT CODE GUIDE



MTBKHA63X20U

1. Type of Product

C	=	Coupler / coupler with excess flow valve
EC	=	End Cap
R	=	Reducer / reducer with excess flow valve
E	=	Elbow
ET	=	Equal Tee
RT	=	Reducing Tee
FT	=	Flanged Tee
MT	=	Multiseal Tapping Tee
FLT	=	Flextee Tapping Tee
MB	=	Branch Saddle
B	=	Branch Saddle
FB	=	Flanged Branch Saddle - Fast Cut
F	=	Flanged Branch Saddle - Flowstop
ZC	=	Male Transition Coupler
XC	=	Female Transition Coupler
ZE	=	Male Transition Elbow
XE	=	Female Transition Elbow
XB	=	Balloon Saddle / Transition Saddle
PES	=	PE – Steel Transition Piece
DFB	=	Duckfoot Bend Kit / Duckfoot bend
HBSH	=	Hydrant Branch Saddle Kit
SFHK	=	Stub Flange Kit

2. Colour of Fitting

BKH	=	Black PE100
-----	---	-------------

3. Welding method guide

A	=	4.7mm Automatic Pin
M	=	4.7mm Manual Pin
FM	=	4mm Manual Pin

4. Size Guide

40X20	=	40mm x 20mm
63X20	=	63mm x 20mm

5. Extras

U	=	Underpart
UT	=	Underpart and Tube
T	=	Tube
DP	=	Dual Purpose
ALH	=	For use with flow stop equipment
EFV	=	Excess Flow Valve
W	=	Weldable
KR	=	Kit with Rilsan Backing Ring
K	=	Kit
LP	=	Low Pressure



AVK INSTALLATION TRACKER IS THE NEW ASSET MANAGEMENT SYSTEM* FROM AVK FOR VALVES, FITTINGS AND ASSOCIATED PRODUCTS. UTILISING A NEW, PURPOSE BUILT, USER FRIENDLY MOBILE APP & WEB PORTAL.

AVK installation tracker uses a QR/barcode platform, designed to give full traceability of your assets providing the data on each installed asset, and gives the opportunity to review the quality of the joints and the installation. This, combined with a unique GPS pin location and a picture of each installation, ensures that you have a complete, accurate and auditable record of every installation. Furthermore, all the data recorded can be exported into standard data formats for integration into the clients existing mapping system.

* Patent pending.



FULL TRACEABILITY IN A FEW SIMPLE STEPS...

The QR code is generated when the asset successfully passes all the relevant test procedures. It assigns a unique serial number for the product which is linked to the full material and test records. When installed the data record becomes complete from raw material to accurate position and application.



DOWNLOAD THE APP



SCAN THE QR/BAR CODE



SET LOCATION

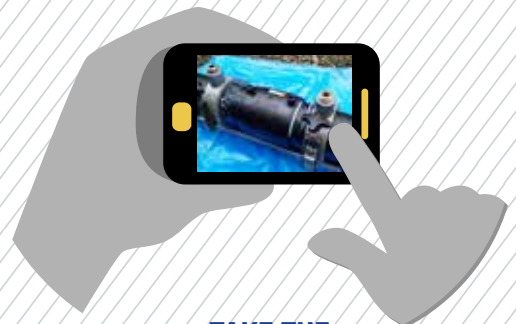

TAKE THE INSTALLATION PICTURE



THE APP



WEB PORTAL



Scan the QR / barcode using the App



Accurate GPS pin gives location



Secure Customer log in



Asset location on map (colours represent different pressures)



The pin shows asset location

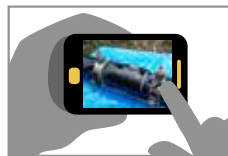

Take an installation picture



Verify pictorial record



Data record includes: asset type, materials, size, pressure and who installed the asset

AVK INSTALLATION TRACKER HAS ALL YOU NEED TO MANAGE FUTURE TRACEABILITY

Access to the recorded data, collected from the app is via a user friendly web portal providing at a glance accurate records.



INCREASED ASSET TRACEABILITY



VISUALLY AUDIT THE INSTALLATION QUALITY



RECORD INDIVIDUAL ASSET INSTALLATIONS



EXPORTABLE DATA INTO STANDARD FORMATS



ACCURATE GPS PIN LOCATION



PERIODIC INSTALLATION AUDIT REPORT AVAILABLE

Coupler



- PE100
- Water PN16
- Gas 10 Bar
- d20-400

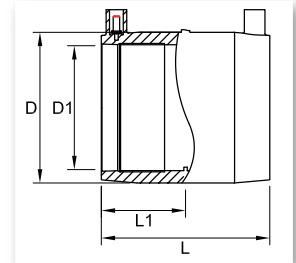

4mm Pin Fitting Code	4.7mm Pin Fitting Code	Fitting Size	L	L1	D	D1	Fusion Time	Cooling Time	Weight	Box Quantity	Box Size (W X L X D)	Delivery Code
		mm									mm	
CBKHFM20	CBKHA20	20	77	37.5	29	20	35	3	0.04	100	295 X 485 X 199	A
CBKHFM25	CBKHA25	25	77	37.5	33.5	25	30	3	0.04	100	295 X 485 X 199	A
CBKHFM32	CBKHA32	32	77	37.5	43	32	45	3	0.06	80	295 X 485 X 199	A
CBKHFM40	CBKHA40	40	90	44	51.5	40	40	5	0.09	100	295 X 485 X 333	A
CBKHFM50	CBKHA50	50	91	44	61.5	50	90	5	0.10	70	295 X 485 X 333	A
CBKHFM63	CBKHA63	63	102	49	77	63	35	3	0.15	30	295 X 485 X 199	A
CBKHFM75	CBKHA75	75	120	59	92	75	50	5	0.27	45	295 X 485 X 424	A
CBKHFM90	CBKHA90	90	122	60	110	90	90	10	0.39	30	295 X 485 X 424	A
CBKHFM110	CBKHA110	110	144	70	133	110	160	10	0.57	14	295 X 485 X 333	A
CBKHFM125	CBKHA125	125	154	75	151	125	200	10	0.78	12	295 X 485 X 333	A
CBKHFM140	CBKHA140	140	165	79	172	140	160	10	1.12	6	295 X 485 X 333	A
CBKHFM160	CBKHA160	160	175	86	195	160	300	20	1.41	4	232 X 453 X 387	A
CBKHFM180	CBKHA180	180	185	91	220	180	360	20	1.92	4	232 X 453 X 387	A
CBKHFM200	CBKHA200	200	186	92	243	200	440	20	2.31	4	295 X 485 X 424	A
CBKHFM225	CBKHA225	225	222	111	270	225	600	30	3.65	2	295 X 485 X 333	A
CBKHFM250	CBKHA250	250	222	111	300	250	900	30	4.64	2	295 X 485 X 333	A
CBKHFM280	CBKHA280	280	260	130	335	280	900	30	8.32	1	435 X 330 X 369	A
CBKHFM315	CBKHM315	315	260	130	377	315	1140	30	8.4	1	295 X 485 X 424	A
CBKHFM355	CBKHM355	355	265	132.5	425	355	1200	30	10.95	1	295 X 485 X 424	A
CBKHFM400	CBKHM400	400	290	145	478	400	1680	30	14.7	1	300 x 490 x 490	A

Large Diameter Coupler



- PE100
- FSN - SDR 11 - 26 - Water PN16 / Gas 10 Bar
- FSV - SDR 17 - 26 - Water PN10 / Gas 6 Bar
- d450-630
- d710-1200 available on request

* Couplers greater than 500mm in diameter require two electrofusion cycles (dual shot), one for each end of the fitting.

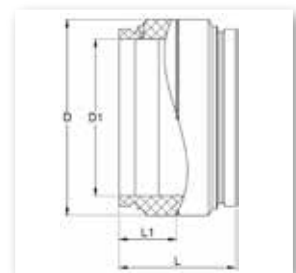

4mm Pin Fitting Code	4.7mm Pin Fitting Code	Fitting Size	L	L1	D	D1	Fusion Time	Cooling Time	Weight	Box Quantity	Box Size (W X L X D)	Delivery Code
		mm									mm	
CBKHFM450FSN	CBKHM450FSN	450	320	160	522	450	1380	30	21.00	1	570 X 570 X 335	A
CBKHFM450FSV	CBKHM450FSV	450	320	160	560	450	1380	30	15.00	1	530 X 530 X 335	A
CBKHFM500FSN	CBKHM500FSN	500	360	180	621	500	1800	30	33.00	1	635 X 635 X 375	A
CBKHFM500FSV	CBKHM500FSV	500	360	180	579	500	1800	30	20.00	1	590 X 590 X 370	A
CBKHFM560FSN	CBKHM560FSN	560	390	195	694	560	960 *	45	39.00	1	705 X 705 X 405	A
CBKHFM560FSV	CBKHM560FSV	560	390	195	644	560	960 *	45	26.00	1	655 X 655 X 405	A
CBKHFM630FSN	CBKHM630FSN	630	430	215	780	630	1620 *	30	53.00	1	790 X 790 X 445	A
CBKHFM630FSV	CBKHM630FSV	630	430	215	723	630	1380 *	30	35.00	1	735 X 735 X 445	A

Low Pressure Coupler



- PE100
- Water PN10
- d110-400

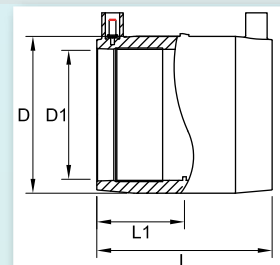

4mm Pin Fitting Code	4.7mm Pin Fitting Code	Fitting Size	L	L1	D	D1	Fusion Time	Cooling Time	Weight	Box Quantity	Box Size (W X L X D)	Delivery Code
		mm	mm	mm	mm	mm	secs	mins	Kg		mm	
CBKHFM110LP	CBKHA110LP	110	144	70	133	110	100	10	0.52	14	295 X 485 X 333	A
CBKHFM125LP	CBKHA125LP	125	154	75	151	125	160	10	0.74	12	295 X 485 X 333	A
CBKHFM160LP	CBKHA160LP	160	175	86	195	160	240	20	1.409	4	232 X 453 X 387	A
CBKHFM180LP	CBKHA180LP	180	185	91	220	180	300	15	1.906	4	295 X 485 X 424	A
CBKHFM200LP	CBKHA200LP	200	186	92	243	200	360	15	2.301	4	295 X 485 X 424	A
CBKHFM250LP	CBKHA250LP	250	222	111	288	250	600	30	3.3	2	295 X 485 X 333	A
CBKHFM315LP	CBKHA315LP	315	260	130	360	315	900	30	5.9	1	295 X 485 X 424	A
CBKHFM400LP	CBKHA400LP	400	290	145	460	400	1800	30	11.2	1	475 X 475 X 305	A

End Cap



- PE100
- Water PN16
- Gas 10 Bar
- d20-250

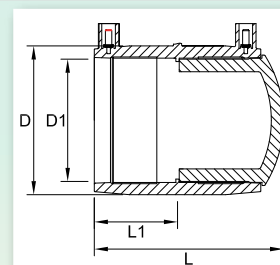

4mm Pin Fitting Code	4.7mm Pin Fitting Code	Fitting Size	L	L1	D	D1	Fusion Time	Cooling Time	Weight	Box Quantity	Box Size (W X L X D)	Delivery Code
		mm	mm	mm	mm	mm	secs	mins	Kg		mm	
ECBKHF20	ECBKA20	20	82	37.5	29	20	35	3	0.04	100	295 X 485 X 199	A
ECBKHF25	ECBKA25	25	82	37.5	33.5	25	30	3	0.05	100	295 X 485 X 199	A
ECBKHF32	ECBKA32	32	84	37.5	43	32	45	3	0.08	80	295 X 485 X 199	A
ECBKHF40	ECBKA40	40	97	44	51.5	40	40	5	0.11	100	295 X 485 X 333	A
ECBKHF50	ECBKA50	50	101	44	61.5	50	90	5	0.14	70	295 X 485 X 333	A
ECBKHF63	ECBKA63	63	115	49	77	63	35	3	0.23	30	295 X 485 X 199	A
ECBKHF75	ECBKA75	75	133	59	92	75	50	5	0.39	20	295 X 485 X 199	A
ECBKHF90	ECBKA90	90	138	60	110	90	90	10	0.57	24	295 X 485 X 333	A
ECBKHF110	ECBKA110	110	164	70	133	110	160	10	0.89	14	295 X 485 X 333	A
ECBKHF125	ECBKA125	125	175	75	151	125	200	10	1.22	10	295 X 485 X 333	A
ECBKHF140	ECBKA140	140	236	79	172	140	160	10	2.25	6	295 X 485 X 333	A
ECBKHF160	ECBKA160	160	202	86	195	160	300	20	2.24	4	232 X 453 X 387	A
ECBKHF180	ECBKA180	180	214	91	220	180	360	20	3.13	4	295 X 485 X 424	A
ECBKHF200	ECBKA200	200	215	92	243	200	440	20	4.02	4	295 X 485 X 424	A
ECBKHF225	ECBKA225	225	222	109	270	225	600	30	7.00	2	295 X 485 X 333	A
ECBKHF250	ECBKA250	250	220	108	295	250	900	30	8.10	2	295 X 485 X 333	A

Reducer

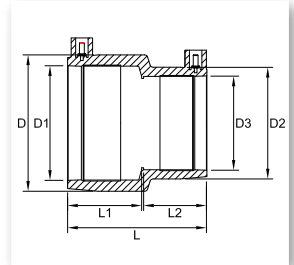

- PE100
- Water PN16
- Gas 10 Bar
- d25x20 - 180x125

4mm Pin Fitting Code	4.7mm Pin Fitting Code	Fitting Size	L	L1	D	D1	L2	D2	D3	Fusion Time	Cooling Time	Weight	Box Quantity	Box Size (W X L X D)	Delivery Code
														mm	
RBKHF25X20	RBKHA25X20	25 x 20	77	38.5	34	25	36.5	29	20	35	3	0.04	100	295 X 485 X 199	A
RBKHF32X20	RBKHA32X20	32 x 20	77	38.5	43	32	36.5	29	20	40	3	0.05	100	295 X 485 X 199	A
RBKHF32X25	RBKHA32X25	32 x 25	77	38.5	43	32	37.0	34	25	30	3	0.05	80	295 X 485 X 199	A
RBKHF40X32	RBKHA40X32	40 x 32	91	46	52	40	43	44	32	50	5	0.08	100	295 X 485 X 333	A
RBKHF50X32	RBKHA50X32	50 x 32	91	46.5	62	50	41	44	32	60	5	0.09	80	295 X 485 X 333	A
RBKHF50X40	RBKHA50X40	50 x 40	91	46.0	62	50	43	52	40	60	5	0.10	80	295 X 485 X 333	A
RBKHF63X32	RBKHA63X32	63 x 32	102	52	78	63	44	44	32	90	5	0.14	60	295 X 485 X 333	A
RBKHF63X40	RBKHA63X40	63 x 40	102	52	78	63	45	52	40	70	5	0.14	60	295 X 485 X 333	A
RBKHF63X50	RBKHA63X50	63 x 50	102	52	78	63	48	62	50	120	10	0.15	60	295 X 485 X 333	A
RBKHF75X63	RBKHA75X63	75 x 63	126	61	98	75	57	82	63	80	8	0.44	24	295 X 485 X 424	A
RBKHF90X63	RBKHA90X63	90 x 63	122.5	61	109.5	90	55	79	63	80	5	0.31	35	295 X 485 X 424	A
RBKHF110X63	RBKHA110X63	110 x 63	136.5	75	140	110	54	98	63	120	8	0.59	18	295 X 485 X 424	A
RBKHF110X90	RBKHA110X90	110 x 90	137.0	68	134	110	62	112	90	120	10	0.55	20	295 X 485 X 424	A
RBKHF125X90	RBKHA125X90	125 x 90	145	75	152	125	62.5	112	90	160	10	0.70	12	295 X 485 X 333	A
RBKHF160X90	RBKHA160X90	160 x 90	175	92	187	160	68	116	90	300	20	1.51	6	295 X 485 X 424	A
RBKHF160X110	RBKHA160X110	160 x 110	184	89	200	160	73	140	110	320	20	1.64	6	295 X 485 X 424	A
RBKHF180X125	RBKHA180X125	180 x 125	221	101	216	180	83	157	125	220	10	2.16	4	232 X 453 X 387	A

90° Elbow

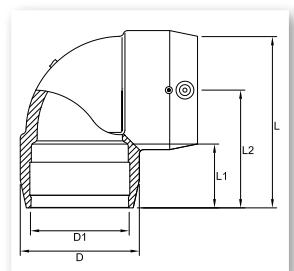

- PE100
- Water PN16
- Gas 10 Bar
- d20-180

4mm Pin Fitting Code	4.7mm Pin Fitting Code	Fitting Size	L	L1	L2	D	D1	Fusion Time	Cooling Time	Weight	Box Quantity	Box Size (W X L X D)	Delivery Code
												mm	
EBKHF20X90	EBKHA20X90	20 x 90deg	82	44	64	36	20	35	3	0.15	40	295 X 485 X 199	A
EBKHF25X90	EBKHA25X90	25 x 90deg	76	41	60	35	25	30	5	0.06	100	295 X 485 X 333	A
EBKHF32X90	EBKHA32X90	32 x 90deg	84	40	62	44	32	60	5	0.10	80	295 X 485 X 333	A
EBKHF40X90	EBKHA40X90	40 x 90deg	91	42	65	52	40	50	5	0.12	65	295 X 485 X 333	A
EBKHF50X90	EBKHA50X90	50 x 90deg	103	45	72	63	50	90	5	0.17	50	295 X 485 X 333	A
EBKHF63X90	EBKHA63X90	63 x 90deg	123	50	84	80	63	35	5	0.31	25	295 X 485 X 333	A
EBKHF75X90	EBKHA75X90	75 x 90deg	141	53	92	95	75	70	5	0.44	20	295 X 485 X 333	A
EBKHF90X90	EBKHA90X90	90 x 90deg	165	60	109	113	90	90	10	0.68	15	295 X 485 X 424	A
EBKHF110X90	EBKHA110X90	110 x 90deg	204	73	135	137	110	160	15	1.15	6	295 X 485 X 333	A
EBKHF125X90	EBKHA125X90	125 x 90deg	228	75	152	154	125	200	15	1.64	6	295 X 485 X 424	A
EBKHF160X90	EBKHA160X90	160 x 90deg	305	87	205	201	160	360	20	5.00	2	295 X 485 X 424	A
EBKHF180X90	EBKHA180X90	180 x 90deg	308	90	197	222	180	360	16	4.12	2	575 X 315 X 329	A



45° Elbow

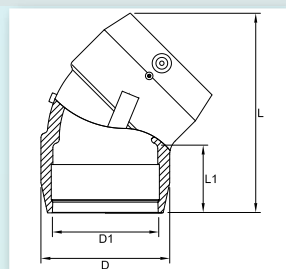

- PE100
- Water PN16
- Gas 10 Bar
- d32-180

4mm Pin Fitting Code	4.7mm Pin Fitting Code	Fitting Size	L	L1	D	D1	Fusion Time	Cooling Time	Weight	Box Quantity	Box Size (W X L X D)	Delivery Code
		mm	mm	mm	mm	mm	secs	mins	Kg		mm	
EBKHFM32X45	EBKHA32X45	32 x 45deg	99	39	44	32	45	5	0.08	100	295 X 485 X 333	A
EBKHFM40X45	EBKHA40X45	40 x 45deg	108	41.5	53	40	50	5	0.10	70	295 X 485 X 333	A
EBKHFM50X45	EBKHA50X45	50 x 45deg	124	44.5	64	50	90	5	0.14	50	295 X 485 X 333	A
EBKHFM63X45	EBKHA63X45	63 x 45deg	137	50	78.5	63	35	5	0.23	30	295 X 485 X 333	A
EBKHFM75X45	EBKHA75X45	75 x 45deg	165	54	94	75	70	5	0.35	20	295 X 485 X 333	A
EBKHFM90X45	EBKHA90X45	90 x 45deg	177	60	117	90	110	10	0.55	18	295 X 485 X 424	A
EBKHFM110X45	EBKHA110X45	110 x 45deg	213	75	137	110	140	10	0.93	10	295 X 485 X 424	A
EBKHFM125X45	EBKHA125X45	125 x 45deg	240	81	154	125	140	10	1.25	6	295 X 485 X 424	A
EBKHFM160X45	EBKHA160X45	160 x 45deg	283	89	201	160	360	20	4.50	4	295 X 485 X 333	A
EBKHFM180X45	EBKHA180X45	180 x 45deg	299	90	222	180	360	16	3.13	2	475 X 295 X 314	A

22.5° Elbow

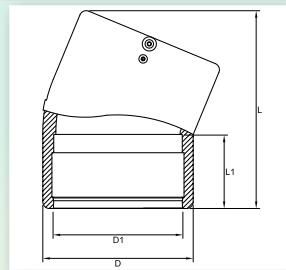

- PE100
- Water PN16
- Gas 10 Bar
- d180

4mm Pin Fitting Code	4.7mm Pin Fitting Code	Fitting Size	L	L1	D	D1	Fusion Time	Cooling Time	Weight	Box Quantity	Box Size (W X L X D)	Delivery Code
		mm	mm	mm	mm	mm	secs	mins	Kg		mm	
EBKHFM180X22.5	EBKHA180X22.5	180 x 22.5deg	278	105	213	180	220	20	2.89	2	295 X 485 X 333	A

Equal Tee

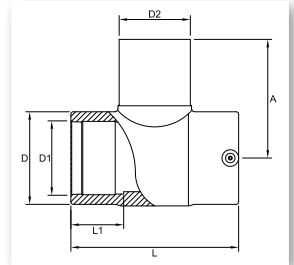

- PE100
- Water PN16
- Gas 10 Bar
- d20-180

4mm Pin Fitting Code	4.7mm Pin Fitting Code	Fitting Size	L	L1	D	D1	D2	A	Fusion Time	Cooling Time	Weight	Box Quantity	Box Size (W X L X D)		Delivery Code
													mm	mm	
ETBKHF20	ETBKHA20	20 x 20 x 20	98	35	30	20	20	86	25	3	0.061	75	465 X 276 X 190	A	
ETBKHF25	ETBKHA25	25 x 25 x 25	98	35	35	25	25	88.5	25	3	0.072	45	465 X 276 X 190	A	
ETBKHF32	ETBKHA32	32 x 32 x 32	98	31.7	44	32	32	93	50	3	0.108	30	465 X 276 X 190	A	
ETBKHF40	ETBKHA40	40 x 40 x 40	131	44	52	40	40	91	50	5	0.16	18	295 X 485 X 199	A	
ETBKHF50	ETBKHA50	50 x 50 x 50	141	43	63	50	50	104	90	5	0.23	25	295 X 485 X 333	A	
ETBKHF63	ETBKHA63	63 x 63 x 63	156	50	82	63	63	114	40	5	0.45	20	295 X 485 X 424	A	
ETBKHF75	ETBKHA75	75 x 75 x 75	174	55	100	75	75	134	50	6	0.60	12	295 X 485 X 333	A	
ETBKHF90	ETBKHA90	90 x 90 x 90	206	64	115	90	90	143	110	8	0.97	10	295 X 485 X 333	A	
ETBKHF110	ETBKHA110	110 x 110 x 110	239	73	139	110	110	157	140	10	1.67	6	295 X 485 X 424	A	
ETBKHF125	ETBKHA125	125 x 125 x 125	264	80	156	125	125	182	200	15	2.30	4	575 X 315 X 329	A	
ETBKHF160	ETBKHA160	160 x 160 x 160	313	89	200	160	160	211	360	20	4.06	2	435 X 335 X 339	A	
ETBKHF180	ETBKHA180	180 x 180 x 180	334	90	222	180	180	232	360	19	5.30	2	435 X 330 X 369	A	

Reducing Tee

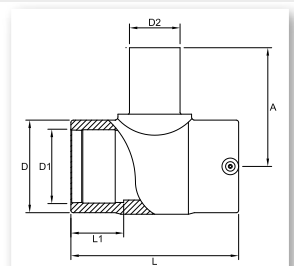

- PE100
- Water PN16
- Gas 10 Bar
- d20x20x32 - 180x180x125

4mm Pin Fitting Code	4.7mm Pin Fitting Code	Fitting Size	L	L1	D	D1	D2	A	Fusion Time	Cooling Time	Weight	Box Quantity	Box Size (W X L X D)		Delivery Code
													mm	mm	
RTBKHF20X32	RTBKHA20X32	20 x 20 x 32	98	35	44	20	32	78	30	3	0.13	50	295 X 485 X 333	A	
RTBKHF25X32	RTBKHA25X32	25 x 25 x 32	98	35	44	25	32	78	35	3	0.13	50	295 X 485 X 333	A	
RTBKHF50X40	RTBKHA50X40	50 x 50 x 40	144	49	67	50	40	101	120	10	0.29	25	295 X 485 X 333	A	
RTBKHF63X40	RTBKHA63X40	63 x 63 x 40	154	34	81	63	40	108	40	5	0.40	24	295 X 485 X 333	A	
RTBKHF63X50	RTBKHA63X50	63 x 63 x 50	157	51	83	63	50	118	40	5	0.42	26	295 X 485 X 424	A	
RTBKHF90X63	RTBKHA90X63	90 x 90 x 63	206	63	115.5	90	63	138	110	8	0.88	12	295 X 485 X 424	A	
RTBKHF110X63	RTBKHA110X63	110 x 110 x 63	239	73	142	110	63	147	140	10	1.47	8	295 X 485 X 424	A	
RTBKHF110X90	RTBKHA110X90	110 x 110 x 90	239	73	139	110	90	162	140	10	1.55	6	295 X 485 X 424	A	
RTBKHF125X63*	RTBKHA125X63	125 x 125 x 63	266	79	157	125	63	500	200	15	3.00	3	295 X 485 X 415	A	
RTBKHF125X90	RTBKHA125X90	125 x 125 x 90	264	80	156	125	90	196	200	15	2.28	4	575 X 315 X 329	A	
RTBKHF125X110*	RTBKHA125X110	125 x 125 x 110	262	76	156	125	110	359	200	15	2.80	1	290 X 480 X 415	A	
RTBKHF160X63*	RTBKHA160X63	160 x 160 x 63	365	112	210	160	63	385	360	20	4.10	2	295 X 485 X 333	A	
RTBKHF160X90*	RTBKHA160X90	160 x 160 x 90	365	112	210	160	90	385	360	20	4.10	2	295 X 485 X 333	A	
RTBKHF160X110	RTBKHA160X110	160 x 160 x 110	313	89	200	160	110	202	360	20	3.77	2	435 X 335 X 339	A	
RTBKHF160X125*	RTBKHA160X125	160 x 160 x 125	365	112	213	160	125	410	200	10	7.45	2	295 X 485 X 333	A	
RTBKHF180X125	RTBKHA180X125	180 x 180 x 125	330	90	222	180	125	222	360	19	4.85	2	435 X 330 X 369	A	

*Fabricated fitting

Flanged Tee

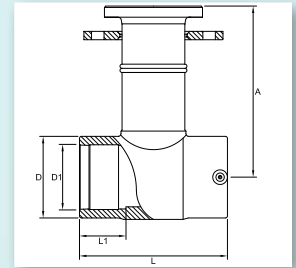

- PE100
- Water PN16
- Gas 10 Bar
- d63xDN50 - d180xDN150

4mm Pin Fitting Code	4.7mm Pin Fitting Code	Fitting Size	L	L1	D	D1	D2	A	Fusion Time	Cooling Time	Weight	Box Quantity	Delivery Code
			mm	mm	mm	mm	mm	mm	mm	secs	mins		
FTBKHF63X50	FTBKHA63X50	63 x 50	156	50	82	63	63	251	40	5	0.14	1	A
FTBKHF90X50	FTBKHA90X50	90 x 50	206	64	115	90	63	307	110	8	0.13	1	A
FTBKHF90X80	FTBKHA90X80	90 x 80	206	64	115	90	90	307	110	8	0.11	1	A
FTBKHF110X100	FTBKHA110X100	110 x 100	239	73	139	110	110	353	140	10	0.16	1	A
FTBKHF125X80	FTBKHA125X80	125 x 80	239	80	156	125	90	526	200	15	0.23	1	A
FTBKHF125X100	FTBKHA125X100	125 x 100	264	80	156	125	110	353	200	15	0.45	1	A
FTBKHF160X100	FTBKHA160X100	160 x 100	313	89	200	160	110	596	360	20	0.60	1	A
FTBKHF160X150	FTBKHA160X150	160 x 150	313	89	200	160	160	436	360	20	0.97	1	A
FTBKHF180X80	FTBKHA180X80	180 x 80	330	90	222	180	90	766	360	19	1.67	1	A
FTBKHF180X100	FTBKHA180X100	180 x 100	330	90	222	180	125	575	360	19	2.30	1	A
FTBKHF180X150	FTBKHA180X150	180 x 150	330	90	222	180	180	436	360	19	4.06	1	A

Multiseal Tapping Tee Stackload

20 - 32mm Outlet



- PE100
- Water PN16
- Gas 10 Bar
- For UK Gas applications:
 - Gas 5.5 Bar (Class B)
 - Gas 7 Bar (Class C)
- d63x20 - 355x32

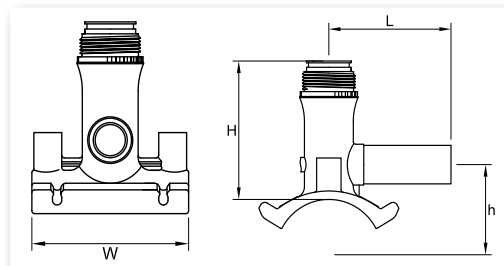

4mm Pin Fitting Code	4.7mm Pin Fitting Code	Fitting Size	L	H	h	W	Fusion Time	Cooling Time	Weight	Box Quantity	Box Size (W X L X D)	Delivery Code
		mm	mm	mm	mm	mm	secs	mins	Kg		mm	
MTBKHF63X20	MTBKHA63X20	63 x 20	105	119	62	120	80	10	0.34	15	295 X 485 X 333	A
MTBKHF63X25	MTBKHA63X25	63 x 25	105	119	62	120	80	10	0.38	15	295 X 485 X 333	A
MTBKHF63X32	MTBKHA63X32	63 x 32	105	119	62	120	80	10	0.38	15	295 X 485 X 333	A
MTBKHF75X20	MTBKHA75X20	75 x 20	105	110	77	120	90	10	0.35	15	295 X 485 X 333	A
MTBKHF75X25	MTBKHA75X25	75 x 25	105	110	77	120	90	10	0.35	15	295 X 485 X 333	A
MTBKHF75X32	MTBKHA75X32	75 x 32	105	110	77	120	90	10	0.35	15	295 X 485 X 333	A
MTBKHF90X20	MTBKHA90X20	90 x 20	105	110	77	120	90	10	0.40	15	295 X 485 X 333	A
MTBKHF90X25	MTBKHA90X25	90 x 25	105	110	77	120	90	10	0.40	15	295 X 485 X 333	A
MTBKHF90X32	MTBKHA90X32	90 x 32	105	110	77	120	90	10	0.40	15	295 X 485 X 333	A
MTBKHF110X20	MTBKHA110X20	110 x 20	105	117	87	120	80	10	0.39	15	295 X 485 X 333	A
MTBKHF110X25	MTBKHA110X25	110 x 25	105	117	87	120	80	10	0.39	15	295 X 485 X 333	A
MTBKHF110X32	MTBKHA110X32	110 x 32	105	117	87	120	80	10	0.39	15	295 X 485 X 333	A
MTBKHF125X20	MTBKHA125X20	125 x 20	105	117	95	120	80	10	0.39	15	295 X 485 X 333	A
MTBKHF125X25	MTBKHA125X25	125 x 25	105	117	95	120	80	10	0.39	15	295 X 485 X 333	A
MTBKHF125X32	MTBKHA125X32	125 x 32	105	117	95	120	80	10	0.39	15	295 X 485 X 333	A
MTBKHF160X20	MTBKHA160X20	160 x 20	105	122	112	120	100	10	0.41	15	295 X 485 X 333	A
MTBKHF160X25	MTBKHA160X25	160 x 25	105	122	112	120	100	10	0.41	15	295 X 485 X 333	A
MTBKHF160X32	MTBKHA160X32	160 x 32	105	122	112	120	100	10	0.41	15	295 X 485 X 333	A
MTBKHF180X20	MTBKHA180X20	180 x 20	105	122	122	120	100	10	0.41	15	295 X 485 X 333	A
MTBKHF180X25	MTBKHA180X25	180 x 25	105	122	122	120	100	10	0.41	15	295 X 485 X 333	A
MTBKHF180X32	MTBKHA180X32	180 x 32	105	122	122	120	100	10	0.41	15	295 X 485 X 333	A
MTBKHF200X20	MTBKHA200X20	200 x 20	105	122	132	120	100	10	0.38	15	295 X 485 X 333	A
MTBKHF200X25	MTBKHA200X25	200 x 25	105	122	132	120	100	10	0.38	15	295 X 485 X 333	A
MTBKHF200X32	MTBKHA200X32	200 x 32	105	122	132	120	100	10	0.38	15	295 X 485 X 333	A
MTBKHF225X20	MTBKHA225X20	225 x 20	105	122	145	120	100	10	0.41	15	295 X 485 X 333	A
MTBKHF225X25	MTBKHA225X25	225 x 25	105	122	145	120	100	10	0.41	15	295 X 485 X 333	A
MTBKHF225X32	MTBKHA225X32	225 x 32	105	122	145	120	100	10	0.41	15	295 X 485 X 333	A
MTBKHF250X20	MTBKHA250X20	250 x 20	105	122	158	120	100	10	0.37	15	295 X 485 X 333	A
MTBKHF250X25	MTBKHA250X25	250 x 25	105	122	158	120	100	10	0.37	15	295 X 485 X 333	A
MTBKHF250X32	MTBKHA250X32	250 x 32	105	122	158	120	100	10	0.37	15	295 X 485 X 333	A
MTBKHF280X20	MTBKHA280X20	280 x 20	105	122	176	120	100	10	0.41	15	295 X 485 X 333	A
MTBKHF280X25	MTBKHA280X25	280 x 25	105	122	176	120	100	10	0.41	15	295 X 485 X 333	A
MTBKHF280X32	MTBKHA280X32	280 x 32	105	122	176	120	100	10	0.41	15	295 X 485 X 333	A
MTBKHF315X20	MTBKHA315X20	315 x 20	105	122	194	120	100	10	0.41	15	295 X 485 X 333	A
MTBKHF315X25	MTBKHA315X25	315 x 25	105	122	194	120	100	10	0.41	15	295 X 485 X 333	A
MTBKHF315X32	MTBKHA315X32	315 x 32	105	122	194	120	100	10	0.41	15	295 X 485 X 333	A
MTBKHF355X20	MTBKHA355X20	355 x 20	105	122	214	120	100	10	0.40	15	295 X 485 X 333	A
MTBKHF355X25	MTBKHA355X25	355 x 25	105	122	214	120	100	10	0.40	15	295 X 485 X 333	A
MTBKHF355X32	MTBKHA355X32	355 x 32	105	122	214	120	100	10	0.40	15	295 X 485 X 333	A

To order Multiseal with the optional cutter tube simply add 'T' to the fitting code e.g. MTBKHA63X32T. The tube works in conjunction with an internal O-ring seal in the body of the fitting to deliver safe live connections.





Multiseal Tapping Tee Stackload

63mm Outlet



- PE100
- Water PN16
- Gas 10 Bar
- For UK Gas applications:
 - Gas 5.5 Bar (Class B)
 - Gas 7 Bar (Class C)
- d250x63 - 355x63
- 40 and 50mm outlet available upon request

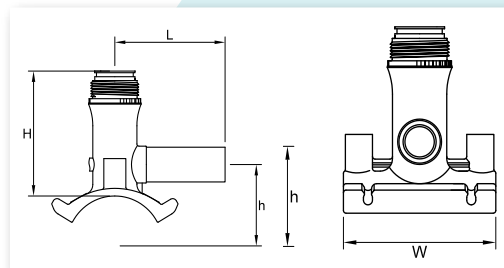

4mm Pin Fitting Code	4.7mm Pin Fitting Code	Fitting Size	L	H	h	W	Fusion Time	Cooling Time	Weight	Box Quantity	Box Size (W X L X D)	Delivery Code
			mm	mm	mm	mm	mm	secs	mins		Kg	
MTBKHF250X63	MTBKHA250X63	250 x 63	165	183	182	146	110	10	0.87	10	295 X 485 X 333	A
MTBKHF280X63	MTBKHA280X63	280 x 63	165	184	196	146	120	10	0.88	10	295 X 485 X 333	A
MTBKHF315X63	MTBKHA315X63	315 x 63	165	187	217	146	120	10	0.89	10	295 X 485 X 333	A
MTBKHF355X63	MTBKHA355X63	355 x 63	165	187	238	146	120	10	0.91	10	295 X 485 X 333	A



To order Multiseal with the optional cutter tube simply add 'T' to the fitting code e.g. MTBKHA250X63T. The tube works in conjunction with an internal O-ring seal in the body of the fitting to deliver safe live connections.





Multiseal Tapping Tee Underclamp

20 - 32mm Outlet



- PE100
- Water PN16
- Gas 10 Bar
- For UK Gas applications:
 - Gas 5.5 Bar (Class B)
 - Gas 7 Bar (Class C)
- d40x20 - 225x32

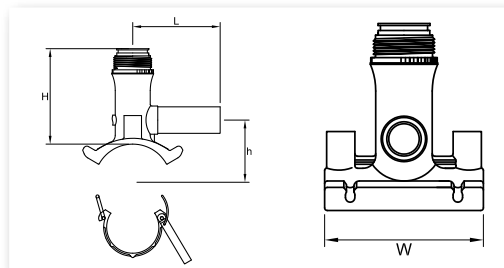

4mm Pin Fitting Code	4.7mm Pin Fitting Code	Fitting Size	L	H	h	W	Fusion Time	Cooling Time	Weight	Box Quantity	Box Size	Delivery Code
											(W X L X D)	
												mm
MTBKHF40X20U	MTBKHA40X20U	40 x 20	105	110	50	120	40	3	0.38	10	295 X 485 X 199	A
MTBKHF40X25U	MTBKHA40X25U	40 x 25	105	110	50	120	40	3	0.38	10	295 X 485 X 199	A
MTBKHF40X32U	MTBKHA40X32U	40 x 32	105	110	50	120	40	3	0.38	10	295 X 485 X 199	A
MTBKHF50X20U	MTBKHA50X20U	50 x 20	105	110	50	120	40	3	0.40	10	295 X 485 X 199	A
MTBKHF50X25U	MTBKHA50X25U	50 x 25	105	110	50	120	40	3	0.40	10	295 X 485 X 199	A
MTBKHF50X32U	MTBKHA50X32U	50 x 32	105	110	50	120	40	3	0.40	10	295 X 485 X 199	A
MTBKHF63X20U	MTBKHA63X20U	63 x 20	105	119	62	120	80	10	0.53	10	295 X 485 X 199	A
MTBKHF63X25U	MTBKHA63X25U	63 x 25	105	119	62	120	80	10	0.53	10	295 X 485 X 199	A
MTBKHF63X32U	MTBKHA63X32U	63 x 32	105	119	62	120	80	10	0.53	10	295 X 485 X 199	A
MTBKHF75X20U	MTBKHA75X20U	75 x 20	105	110	77	120	90	10	0.67	10	295 X 485 X 333	A
MTBKHF75X25U	MTBKHA75X25U	75 x 25	105	110	77	120	90	10	0.67	10	295 X 485 X 333	A
MTBKHF75X32U	MTBKHA75X32U	75 x 32	105	110	77	120	90	10	0.67	10	295 X 485 X 333	A
MTBKHF90X20U	MTBKHA90X20U	90 x 20	105	110	77	120	90	10	0.61	10	295 X 485 X 333	A
MTBKHF90X25U	MTBKHA90X25U	90 x 25	105	110	77	120	90	10	0.61	10	295 X 485 X 333	A
MTBKHF90X32U	MTBKHA90X32U	90 x 32	105	110	77	120	90	10	0.61	10	295 X 485 X 333	A
MTBKHF110X20U	MTBKHA110X20U	110 x 20	105	117	87	120	80	10	0.65	10	295 X 485 X 333	A
MTBKHF110X25U	MTBKHA110X25U	110 x 25	105	117	87	120	80	10	0.65	10	295 X 485 X 333	A
MTBKHF110X32U	MTBKHA110X32U	110 x 32	105	117	87	120	80	10	0.65	10	295 X 485 X 333	A
MTBKHF125X20U	MTBKHA125X20U	125 x 20	105	117	95	120	80	10	0.66	10	295 X 485 X 333	A
MTBKHF125X25U	MTBKHA125X25U	125 x 25	105	117	95	120	80	10	0.66	10	295 X 485 X 333	A
MTBKHF125X32U	MTBKHA125X32U	125 x 32	105	117	95	120	80	10	0.67	10	295 X 485 X 333	A
MTBKHF160X20U	MTBKHA160X20U	160 x 20	105	122	112	120	100	10	0.73	10	295 X 485 X 333	A
MTBKHF160X25U	MTBKHA160X25U	160 x 25	105	122	112	120	100	10	0.73	10	295 X 485 X 333	A
MTBKHF160X32U	MTBKHA160X32U	160 x 32	105	122	112	120	100	10	0.73	10	295 X 485 X 333	A
MTBKHF180X20U	MTBKHA180X20U	180 x 20	105	122	122	120	100	10	0.75	10	295 X 485 X 333	A
MTBKHF180X25U	MTBKHA180X25U	180 x 25	105	122	122	120	100	10	0.75	10	295 X 485 X 333	A
MTBKHF180X32U	MTBKHA180X32U	180 x 32	105	122	122	120	100	10	0.75	10	295 X 485 X 333	A
MTBKHF200X20U	MTBKHA200X20U	200 x 20	105	122	132	120	100	10	0.73	10	295 X 485 X 333	A
MTBKHF200X25U	MTBKHA200X25U	200 x 25	105	122	132	120	100	10	0.73	10	295 X 485 X 333	A
MTBKHF200X32U	MTBKHA200X32U	200 x 32	105	122	132	120	100	10	0.73	10	295 X 485 X 333	A
MTBKHF225X20U	MTBKHA225X20U	225 x 20	105	122	145	120	100	10	0.78	10	295 X 485 X 424	A
MTBKHF225X25U	MTBKHA225X25U	225 x 25	105	122	145	120	100	10	0.78	10	295 X 485 X 424	A
MTBKHF225X32U	MTBKHA225X32U	225 x 32	105	122	145	120	100	10	0.78	10	295 X 485 X 424	A

To order Multiseal with the optional cutter tube simply add 'T' to the fitting code e.g. MTBKHA63X32UT. The tube works in conjunction with an internal O-ring seal in the body of the fitting to deliver safe live connections.



Multiseal Tapping Tee Underclamp

40 - 63mm Outlet



- PE100
- Water PN16
- Gas 10 Bar
- For UK Gas applications:
 - Gas 5.5 Bar (Class B)
 - Gas 7 Bar (Class C)
- d63x40 - 225x63

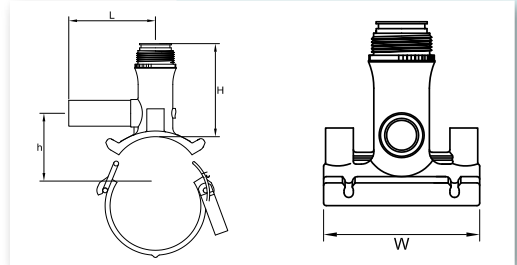

4mm Pin Fitting Code	4.7mm Pin Fitting Code	Fitting Size	L	H	h	W	Fusion Time	Cooling Time	Weight	Box Quantity	Box Size	Delivery Code
											(W X L X D)	
												mm
MTBKHF63X40U	MTBKHA63X40U	63 x 40	165	155	59.5	146	100	10	0.95	5	295 X 485 X 333	B
MTBKHF63X50U	MTBKHA63X50U	63 x 50	165	155	59.5	146	100	10	0.96	5	295 X 485 X 333	B
MTBKHF63X63U	MTBKHA63X63U	63 x 63	165	155	59.5	146	100	10	1.01	5	295 X 485 X 333	A
MTBKHF75X40U	MTBKHA75X40U	75 x 40	165	152	57	146	120	10	1.10	5	295 X 485 X 333	B
MTBKHF75X50U	MTBKHA75X50U	75 x 50	165	152	57	146	120	10	1.10	5	295 X 485 X 333	B
MTBKHF75X63U	MTBKHA75X63U	75 x 63	165	152	57	146	120	10	1.15	5	295 X 485 X 333	A
MTBKHF90X40U	MTBKHA90X40U	90 x 40	165	152	57	146	100	10	1.06	5	295 X 485 X 333	B
MTBKHF90X50U	MTBKHA90X50U	90 x 50	165	152	57	146	100	10	1.10	5	295 X 485 X 333	B
MTBKHF90X63U	MTBKHA90X63U	90 x 63	165	152	57	146	100	10	1.12	5	295 X 485 X 333	A
MTBKHF110X40U	MTBKHA110X40U	110 x 40	165	176	105	146	100	10	1.09	5	295 X 485 X 333	B
MTBKHF110X50U	MTBKHA110X50U	110 x 50	165	176	105	146	100	10	1.10	5	295 X 485 X 333	B
MTBKHF110X63U	MTBKHA110X63U	110 x 63	165	176	105	146	100	10	1.15	5	295 X 485 X 333	A
MTBKHF125X40U	MTBKHA125X40U	125 x 40	165	178	112	146	100	10	1.10	5	295 X 485 X 333	B
MTBKHF125X50U	MTBKHA125X50U	125 x 50	165	178	112	146	100	10	1.15	5	295 X 485 X 333	B
MTBKHF125X63U	MTBKHA125X63U	125 x 63	165	178	112	146	100	10	1.20	5	295 X 485 X 333	A
MTBKHF160X40U	MTBKHA160X40U	160 x 40	165	182	137	146	100	10	1.13	5	295 X 485 X 333	B
MTBKHF160X50U	MTBKHA160X50U	160 x 50	165	182	137	146	100	10	1.14	5	295 X 485 X 333	B
MTBKHF160X63U	MTBKHA160X63U	160 x 63	165	182	137	146	100	10	1.19	5	295 X 485 X 333	A
MTBKHF180X40U	MTBKHA180X40U	180 x 40	165	183	147	146	100	10	1.15	5	295 X 485 X 333	B
MTBKHF180X50U	MTBKHA180X50U	180 x 50	165	183	147	146	100	10	1.17	5	295 X 485 X 333	B
MTBKHF180X63U	MTBKHA180X63U	180 x 63	165	183	147	146	100	10	1.22	5	295 X 485 X 333	A
MTBKHF200X40U	MTBKHA200X40U	200 x 40	165	183	157	146	100	10	1.15	5	295 X 485 X 333	B
MTBKHF200X50U	MTBKHA200X50U	200 x 50	165	183	157	146	100	10	1.17	5	295 X 485 X 333	B
MTBKHF200X63U	MTBKHA200X63U	200 x 63	165	183	157	146	100	10	1.21	5	295 X 485 X 333	A
MTBKHF225X40U	MTBKHA225X40U	225 x 40	165	183	169	146	100	10	1.15	5	295 X 485 X 333	B
MTBKHF225X50U	MTBKHA225X50U	225 x 50	165	183	169	146	100	10	1.17	5	295 X 485 X 333	B
MTBKHF225X63U	MTBKHA225X63U	225 x 63	165	183	169	146	100	10	1.22	5	295 X 485 X 333	A

To order Multiseal with the optional cutter tube simply add 'T' to the fitting code e.g. MTBKHA225X40UT. The tube works in conjunction with an internal O-ring seal in the body of the fitting to deliver safe live connections.



Flextee Tapping Tee Underclamp



- PE100
- Water PN16
- Gas 10 Bar
- d63x20 - 180x32

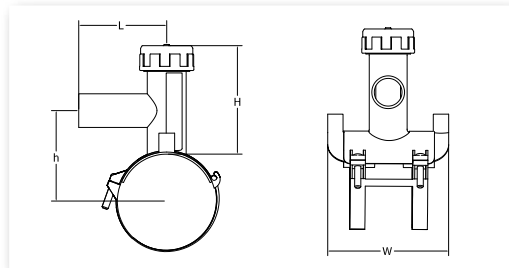

4mm Pin Fitting Code	4.7mm Pin Fitting Code	Fitting Size	L	H	h	W	Fusion Time	Cooling Time	Weight	Box Quantity	Box Size (W X L X D)	Delivery Code
FLTBKHF63X20U	FLTBKHA63X20U	63 x 20	83	100	59.5	119	110	10	0.22	10	295 X 485 X 199	A
FLTBKHF63X25U	FLTBKHA63X25U	63 x 25	83	100	59.5	119	110	10	0.22	10	295 X 485 X 199	A
FLTBKHF63X32U	FLTBKHA63X32U	63 x 32	83	100	59.5	119	110	10	0.22	10	295 X 485 X 199	A
FLTBKHF75X20U	FLTBKHA75X20U	75 x 20	83	100	65.5	119	110	10	0.22	10	295 X 485 X 199	A
FLTBKHF75X25U	FLTBKHA75X25U	75 x 25	83	100	65.5	119	110	10	0.22	10	295 X 485 X 199	A
FLTBKHF75X32U	FLTBKHA75X32U	75 x 32	83	100	65.5	119	110	10	0.22	10	295 X 485 X 199	A
FLTBKHF90X20U	FLTBKHA90X20U	90 x 20	83	100	73	119	110	10	0.22	10	295 X 485 X 199	A
FLTBKHF90X25U	FLTBKHA90X25U	90 x 25	83	100	73	119	110	10	0.22	10	295 X 485 X 199	A
FLTBKHF90X32U	FLTBKHA90X32U	90 x 32	83	100	73	119	110	10	0.22	10	295 X 485 X 199	A
FLTBKHF110X20U	FLTBKHA110X20U	110 x 20	93	100	83	119	120	10	0.22	10	295 X 485 X 199	A
FLTBKHF110X25U	FLTBKHA110X25U	110 x 25	93	100	83	119	120	10	0.22	10	295 X 485 X 199	A
FLTBKHF110X32U	FLTBKHA110X32U	110 x 32	93	100	83	119	120	10	0.22	10	295 X 485 X 199	A
FLTBKHF125X20U	FLTBKHA125X20U	125 x 20	93	100	90.5	119	120	10	0.23	10	295 X 485 X 199	A
FLTBKHF125X25U	FLTBKHA125X25U	125 x 25	93	100	90.5	119	120	10	0.23	10	295 X 485 X 199	A
FLTBKHF125X32U	FLTBKHA125X32U	125 x 32	93	100	90.5	119	120	10	0.23	10	295 X 485 X 199	A
FLTBKHF160X20U	FLTBKHA160X20U	160 x 20	93	100	108	119	140	10	0.24	5	295 X 485 X 199	A
FLTBKHF160X25U	FLTBKHA160X25U	160 x 25	93	100	108	119	140	10	0.24	5	295 X 485 X 199	A
FLTBKHF160X32U	FLTBKHA160X32U	160 x 32	93	100	108	119	140	10	0.24	5	295 X 485 X 199	A
FLTBKHF180X20U	FLTBKHA180X20U	180 x 20	93	100	118	119	140	10	0.24	5	295 X 485 X 199	A
FLTBKHF180X25U	FLTBKHA180X25U	180 x 25	93	100	118	119	140	10	0.24	5	295 X 485 X 199	A
FLTBKHF180X32U	FLTBKHA180X32U	180 x 32	93	100	118	119	140	10	0.24	5	295 X 485 X 199	A

Branch Saddle Stackload - 63mm Outlet



- PE100
- Water PN 16
- Gas 10 Bar
- d250x63 - 355x63

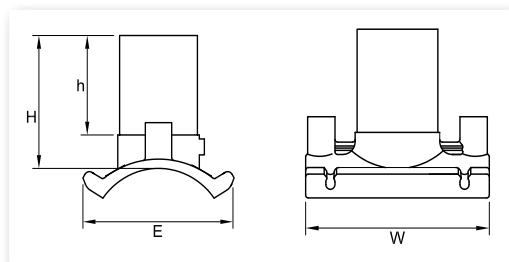

4mm Pin Fitting Code	4.7mm Pin Fitting Code	Fitting Size	E	H	h	W	Fusion Time	Cooling Time	Weight	Box Quantity	Box Size (W X L X D)	Delivery Code
MBBKHF250X63	MBBKHA250X63	250 x 63	125	75	146	122	110	10	0.37	15	295 X 485 X 333	A
MBBKHF280X63	MBBKHA280X63	280 x 63	140	75	146	122	120	10	0.35	15	295 X 485 X 333	A
MBBKHF315X63	MBBKHA315X63	315 x 63	140	75	146	122	120	10	0.38	15	295 X 485 X 333	A
MBBKHF355X63	MBBKHA355X63	355 x 63	140	75	146	122	120	10	0.39	15	295 X 485 X 333	A

Branch Saddle Underclamp - 40 - 63mm Outlet



- PE100
- Water PN16
- Gas 10 Bar
- d63x40 - 225x63

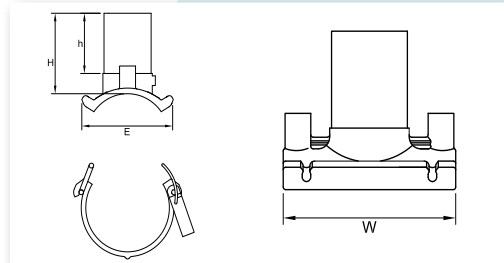

4mm Pin Fitting Code	4.7mm Pin Fitting Code	Fitting Size	E	H	h	W	Fusion Time	Cooling Time	Weight	Box Quantity	Box Size (W X L X D)	Delivery Code
											mm	
MBBKHF63X40U	MBBKHA63X40U	63 x 40	115	75	147	119	100	10	0.48	10	295 X 485 X 333	A
MBBKHF63X50U	MBBKHA63X50U	63 x 50	115	75	147	119	100	10	0.48	10	295 X 485 X 333	A
MBBKHF63X63U	MBBKHA63X63U	63 x 63	115	75	147	119	100	10	0.50	10	295 X 485 X 333	A
MBBKHF75X40U	MBBKHA75X40U	75 x 40	115	75	147	119	120	10	0.63	10	295 X 485 X 333	A
MBBKHF75X50U	MBBKHA75X50U	75 x 50	115	75	147	119	120	10	0.63	10	295 X 485 X 333	A
MBBKHF75X63U	MBBKHA75X63U	75 x 63	115	75	147	119	120	10	0.65	10	295 X 485 X 333	A
MBBKHF90X40U	MBBKHA90X40U	90 x 40	115	75	147	122	100	10	0.61	10	295 X 485 X 333	A
MBBKHF90X50U	MBBKHA90X50U	90 x 50	115	75	147	122	100	10	0.61	10	295 X 485 X 333	A
MBBKHF90X63U	MBBKHA90X63U	90 x 63	115	75	147	122	100	10	0.63	10	295 X 485 X 333	A
MBBKHF110X40U	MBBKHA110X40U	110 x 40	118	75	147	122	100	10	0.62	10	295 X 485 X 333	A
MBBKHF110X50U	MBBKHA110X50U	110 x 50	118	75	147	122	100	10	0.63	10	295 X 485 X 333	A
MBBKHF110X63U	MBBKHA110X63U	110 x 63	118	75	147	122	100	10	0.64	10	295 X 485 X 333	A
MBBKHF125X40U	MBBKHA125X40U	125 x 40	118	75	147	122	100	10	0.62	10	295 X 485 X 333	A
MBBKHF125X50U	MBBKHA125X50U	125 x 50	118	75	147	122	100	10	0.63	10	295 X 485 X 333	A
MBBKHF125X63U	MBBKHA125X63U	125 x 63	118	75	147	122	100	10	0.64	10	295 X 485 X 333	A
MBBKHF160X40U	MBBKHA160X40U	160 x 40	125	75	147	122	100	10	0.65	10	295 X 485 X 333	A
MBBKHF160X50U	MBBKHA160X50U	160 x 50	125	75	147	122	100	10	0.66	10	295 X 485 X 333	A
MBBKHF160X63U	MBBKHA160X63U	160 x 63	125	75	147	122	100	10	0.68	10	295 X 485 X 333	A
MBBKHF180X40U	MBBKHA180X40U	180 x 40	125	75	147	122	100	10	0.68	10	295 X 485 X 333	A
MBBKHF180X50U	MBBKHA180X50U	180 x 50	125	75	147	122	100	10	0.69	10	295 X 485 X 333	A
MBBKHF180X63U	MBBKHA180X63U	180 x 63	125	75	147	122	100	10	0.70	10	295 X 485 X 333	A
MBBKHF200X40U	MBBKHA200X40U	200 x 40	125	75	147	122	100	10	0.68	10	295 X 485 X 424	A
MBBKHF200X50U	MBBKHA200X50U	200 x 50	125	75	147	122	100	10	0.69	10	295 X 485 X 424	A
MBBKHF200X63U	MBBKHA200X63U	200 x 63	125	75	147	122	100	10	0.70	10	295 X 485 X 424	A
MBBKHF225X40U	MBBKHA225X40U	225 x 40	125	75	147	122	100	10	0.72	10	295 X 485 X 424	A
MBBKHF225X50U	MBBKHA225X50U	225 x 50	125	75	147	122	100	10	0.73	10	295 X 485 X 424	A
MBBKHF225X63U	MBBKHA225X63U	225 x 63	125	75	147	122	100	10	0.75	10	295 X 485 X 424	A

Branch Saddle Underclamp - 20 - 63mm Outlet



- PE100
- Water PN16
- Gas 10 Bar
- d40x20 - 90x63

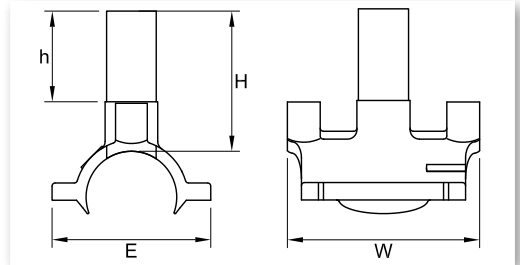

4mm Pin Fitting Code	4.7mm Pin Fitting Code	Fitting Size	E	H	h	W	Fusion Time	Cooling Time	Weight	Box Quantity	Box Size (W X L X D)	Delivery Code
			mm	mm	mm	mm	mm	secs	mins		Kg	
BBKHFM40X20U	BBKHA40X20U	40 x 20	93	51	103	83	50	5	0.19	25	295 X 485 X 199	A
BBKHFM40X25U	BBKHA40X25U	40 x 25	90	52	103	83	50	5	0.19	20	295 X 485 X 199	A
BBKHFM40X32U	BBKHA40X32U	40 x 32	90	57	103	83	50	5	0.19	20	295 X 485 X 199	A
BBKHFM63X20U	BBKHA63X20U	63 x 20	90	50	122	105	140	10	0.31	10	295 X 485 X 199	A
BBKHFM63X25U	BBKHA63X25U	63 x 25	106	59	122	105	140	10	0.31	10	295 X 485 X 199	A
BBKHFM63X32U	BBKHA63X32U	63 x 32	106	59	122	105	140	10	0.31	10	295 X 485 X 199	A
BBKHFM90X20U	BBKHA90X20U	90 x 20	91	51	136	133	140	10	0.42	15	295 X 485 X 333	A
BBKHFM90X25U	BBKHA90X25U	90 x 25	91	51	136	133	140	10	0.43	15	295 X 485 X 333	A
BBKHFM90X32U	BBKHA90X32U	90 x 32	91	51	136	133	140	10	0.44	15	295 X 485 X 333	A
BBKHFM90X40U	BBKHA90X40U	90 x 40	105	69	136	133	140	10	0.45	10	295 X 485 X 333	A
BBKHFM90X50U	BBKHA90X50U	90 x 50	105	82	136	133	140	10	0.47	10	295 X 485 X 333	A
BBKHFM90X63U	BBKHA90X63U	90 x 63	105	88	136	133	140	10	0.50	10	295 X 485 X 333	A

Branch Saddle Underclamp - 90 - 125mm Outlet



- PE100
- Water PN16
- Gas 10 Bar
- d90x90 - 630x125

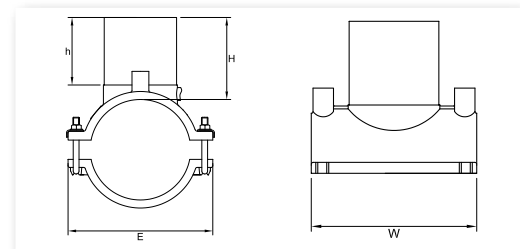

4mm Pin Fitting Code	4.7mm Pin Fitting Code	Fitting Size	E	H	h	W	Fusion Time	Cooling Time	Weight	Box Quantity	Box Size (W X L X D)	Delivery Code
			mm	mm	mm	mm	mm	secs	mins		Kg	
BBKHFM90X90U	BBKHA90X90U	90 x 90	124	84	144	154	100	10	0.93	5	295 X 485 X 333	A
BBKHFM110X90U	BBKHA110X90U	110 x 90	121	84	165	180	120	10	1.22	5	295 X 485 X 333	A
BBKHFM125X90U	BBKHA125X90U	125 x 90	114	84	165	180	120	10	1.13	5	295 X 485 X 333	A
BBKHFM160X90U	BBKHA160X90U	160 x 90	110	84	215	236	120	10	2.10	4	295 X 485 X 333	A
BBKHFM180X90U	BBKHA180X90U	180 x 90	100	84	215	236	120	10	1.94	4	295 X 485 X 333	A
BBKHFM200X90U	BBKHA200X90U	200 x 90	115	84	165	263	120	10	1.99	3	295 X 485 X 333	A
BBKHFM225X90U	BBKHA225X90U	225 x 90	113	84	165	291	120	10	2.20	2	295 X 485 X 333	A
BBKHFM250X90U	BBKHA250X90U	250 x 90	120	84	165	317	120	10	2.66	2	295 X 485 X 333	A
BBKHFM160X110U	BBKHA160X110U	160 x 110	131	98	217	236	120	10	2.27	3	295 X 485 X 333	A
BBKHFM180X110U	BBKHA180X110U	180 x 110	121	98	217	236	120	10	2.11	3	295 X 485 X 333	A
BBKHFM180X125U	BBKHA180X125U	180 x 125	121	98	217	236	120	10	2.16	3	295 X 485 X 333	A
BBKHFM225X125U	BBKHM225X125U	225 x 125	123	98	310	327	500	30	7.37	1	510 X 390 X 380	A
BBKHFM250X125U	BBKHM250X125U	250 x 125	110	98	310	327	500	30	7.37	1	510 X 390 X 380	A
BBKHFM315X110U	BBKHM315X110U	315 x 110	360	195	150	300	460	20	3.6	1	510 X 390 X 380	A
BBKHFM315X125U	BBKHM315X125U	315 x 125	360	195	150	300	460	20	3.6	1	510 X 390 X 380	A
BBKHFM355X110U	BBKHM355X110U	355 x 110	360	195	150	300	460	20	3.6	1	510 X 390 X 380	A
BBKHFM355X125U	BBKHM355X125U	355 x 125	360	195	150	300	460	20	3.6	1	510 X 390 X 380	A
BBKHFM400X110U	BBKHM400X110U	400 x 110	370	195	150	300	460	20	3.6	1	510 X 390 X 380	A
BBKHFM400X125U	BBKHM400X125U	400 x 125	370	195	150	300	460	20	3.6	1	510 X 390 X 380	A
BBKHFM630X110U	BBKHM630X110U	630 x 110	380	195	150	300	460	20	3.6	1	510 X 390 X 380	A
BBKHFM630X125U	BBKHM630X125U	630 x 125	380	195	150	300	460	20	3.6	1	510 X 390 X 380	A



Flanged Branch Saddle Underclamp



- For use with under pressure large diameter drill
- PE100
- Water PN16
- Gas 10 Bar
- d110xDN80 - d630xDN100

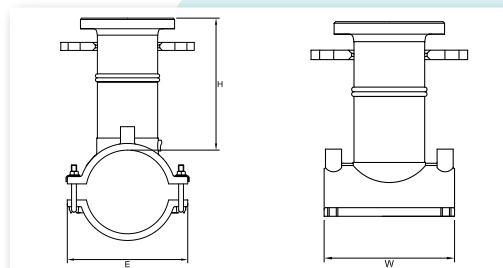

4mm Pin Fitting Code	4.7mm Pin Fitting Code	Fitting Size	H	W	E	Fusion Time	Cooling Time	Weight	Box Quantity	Box Size (W X L X D)	Delivery Code
		mm	mm	mm	mm	secs	mins	Kg		mm	
FBBKHFM110X80U	FBBKHA110X80U	110 x 80 NP16	242	165	180	120	10	1.10	1	510 X 390 X 380	B
FBBKHFM125X80U	FBBKHA125X80U	125 x 80 NP16	242	165	180	120	10	1.05	1	510 X 390 X 380	B
FBBKHFM160X80U	FBBKHA160X80U	160 x 80 NP16	194	215	236	120	10	2.18	1	510 X 390 X 380	B
FBBKHFM160X100U	FBBKHA160X100U	160 x 100 NP16	194	215	236	120	10	2.41	1	510 X 390 X 380	B
FBBKHFM180X80U	FBBKHA180X80U	180 x 80 NP16	242	215	236	120	10	2.04	1	510 X 390 X 380	B
FBBKHFM180X100U	FBBKHA180X100U	180 x 100 NP16	216	215	236	120	10	2.37	1	510 X 390 X 380	B
FBBKHFM200X80U	FBBKHA200X80U	200 x 80 NP16	188	165	263	120	10	4.64	1	510 X 390 X 380	B
FBBKHFM225X80U	FBBKHA225X80U	225 x 80 NP16	188	165	291	120	10	4.74	1	510 X 390 X 380	B
FBBKHFM225X100D	FBBKHM225X100DP	225 x 100 NP16	190	310	320	360	20	9.30	1	510 X 390 X 380	B
FBBKHFM250X80U	FBBKHA250X80U	250 x 80 NP16	193	165	317	120	10	4.81	1	510 X 390 X 380	B
FBBKHFM250X100D	FBBKHM250X100DP	250 x 100 NP16	190	310	320	500	30	9.30	1	510 X 390 X 380	B
FBBKHFM315X100D	FBBKHM315X100DP	315 X 100 NP16	190	300	360	460	20	7.0	1	510 X 390 X 380	B
FBBKHFM355X100D	FBBKHM355X100DP	355 X 100 NP16	190	300	360	460	20	7.0	1	510 X 390 X 380	B
FBBKHFM400X100D	FBBKHM400X100DP	400 X 100 NP16	190	300	360	460	20	7.0	1	510 X 390 X 380	B
FBBKHFM630X100D	FBBKHM630X100DP	630 X 100 NP16	190	300	360	460	20	7.0	1	510 X 390 X 380	B

Flanged Branch Saddle Underclamp - Fastcut



- PE100
- Water PN16
- Gas 10 Bar
- d250xDN150 - d630xDN150

Only available through approved fastcut installers

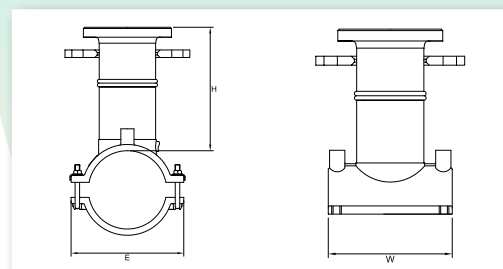

4mm Pin Fitting Code	4.7mm Pin Fitting Code	Fitting Size	H	W	E	Fusion Time	Cooling Time	Weight	Box Quantity	Box Size (W X L X D)	Delivery Code
		mm	mm	mm	mm	secs	mins	Kg		mm	
FBBKHFM250X150D	FBBKHM250X150DP	250 x 150 NP16	190	310	320	360	20	11.40	1	510 X 390 X 380	C
FBBKHFM250X200D	FBBKHM250X200DP	250 x 200 NP16	190	310	320	360	20	12.80	1	510 X 390 X 380	C
FBBKHFM280X150D	FBBKHM280X150DP	280 x 150 NP16	190	310	320	360	20	12.80	1	510 X 390 X 380	C
FBBKHFM280X200D	FBBKHM280X200DP	280 x 200 NP16	190	310	320	360	20	12.80	1	510 X 390 X 380	C
FBBKHFM315X150D	FBBKHM315X150DP	315 x 150 NP16	190	300	360	460	20	7.82	1	295 X 485 X 333	C
FBBKHFM315X250D	FBBKHM315X250DP	315 x 250 NP16	190	420	385	600	30	26.12	1	620 X 465 X 480	C
FBBKHFM355X150D	FBBKHM355X150DP	355 x 150 NP16	190	300	360	460	20	7.48	1	295 X 485 X 333	C
FBBKHFM355X250D	FBBKHM355X250DP	355 x 250 NP16	190	420	425	600	30	25.00	1	620 X 465 X 480	C
FBBKHFM400X150D	FBBKHM400X150DP	400 x 150 NP16	215	300	360	460	20	7.77	1	295 X 485 X 333	C
FBBKHFM400X250D	FBBKHM400X250DP	400 x 250 NP16	215	420	440	600	30	26.94	1	620 X 465 X 480	C
FBBKHFM450X150D	FBBKHM450X150DP	450 x 150 NP16	215	420	530	440	30	22.00	1	620 X 465 X 480	C
FBBKHFM450X250D	FBBKHM450X250DP	450 x 250 NP16	215	420	530	440	30	22.00	1	620 X 465 X 480	C
FBBKHFM500X150D	FBBKHM500X150DP	500 x 150 NP16	215	420	580	440	30	22.00	1	620 X 465 X 480	C
FBBKHFM500X250D	FBBKHM500X250DP	500 x 250 NP16	215	420	580	440	30	22.00	1	620 X 465 X 480	C
FBBKHFM630X150D	FBBKHM630X150DP	630 x 150 NP16	215	300	360	460	20	8.40	1	295 X 485 X 333	C

Flanged Branch Saddle Underclamp ALH Flowstop



- PE100
- Water PN16
- Gas 5.5 Bar
- d315xDN150 - d400xDN150

Only available through approved fastcut installers
For use with ALH flowstop bagtube

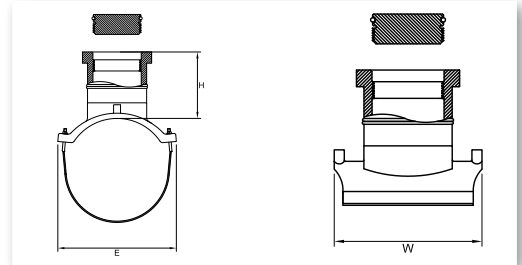

4mm Pin Fitting Code	4.7mm Pin Fitting Code	Fitting Size	H	W	E	Fusion Time	Cooling Time	Weight	Box Quantity	Box Size (W X L X D)	Delivery Code
		mm	mm	mm	mm	secs	mins	Kg	mm		
FBKHFM315X150AL	FBKHA315X150ALH	315 x 150 NP16	190	300	360	440	20	7.82	1	295 X 485 X 333	C
FBKHFM355X150AL	FBKHA355X150ALH	355 x 150 NP16	190	300	360	440	20	7.48	1	620 X 465 X 480	C
FBKHFM400X150AL	FBKHM400X150ALH	400 x 150 NP16	215	300	360	460	20	7.73	1	295 X 485 X 333	C

Balloon Saddle



- PE100
- Water PN16
- Gas 10 Bar
- d90x2½" - 250x2½"

Red cap protects external thread

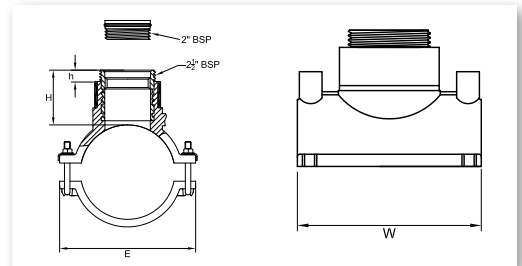

4mm Pin Fitting Code	4.7mm Pin Fitting Code	Fitting Size	H	h	W	E	Fusion Time	Cooling Time	Weight	Box Quantity	Box Size (W X L X D)	Delivery Code
		mm	mm	mm	mm	mm	secs	mins	Kg	mm		
XBBKHFM90X2.5	XBBKHA90X2.5	90 x 2½"	71	15	167	154	100	10	2.05	4	295 X 485 X 199	C
XBBKHFM110X2.5	XBBKHA110X2.5	110 x 2½"	72	15	166	180	120	10	2.35	8	295 X 485 X 199	C
XBBKHFM125X2.5	XBBKHA125X2.5	125 x 2½"	72.5	15	166	180	120	10	2.29	8	295 X 485 X 199	C
XBBKHFM160X2.5	XBBKHA160X2.5	160 x 2½"	84	15	215	236	120	10	3.21	2	295 X 485 X 333	C
XBBKHFM180X2.5	XBBKHA180X2.5	180 x 2½"	74	15	215	236	140	10	2.98	2	295 X 485 X 333	C
XBBKHFM200X2.5	XBBKHA200X2.5	200 x 2½"	82	15	166	263	120	10	3.35	2	295 X 485 X 333	C
XBBKHFM225X2.5	XBBKHA225X2.5	225 x 2½"	80	15	166	300	120	10	3.50	2	295 X 485 X 333	C
XBBKHFM250X2.5	XBBKHA250X2.5	250 x 2½"	86	15	166	317	120	10	3.77	2	295 X 485 X 333	C

Transition Saddle



- PE100
- Water PN16
- Gas 10 Bar
- d63x1¼" - 250x2"

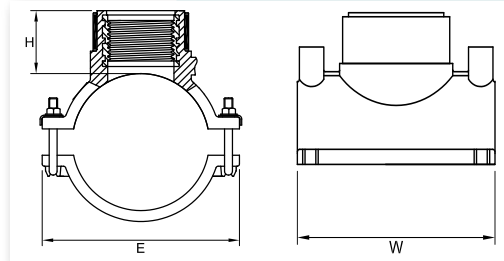

4mm Pin Fitting Code	4.7mm Pin Fitting Code	Fitting Size	H	W	E	Fusion Time	Cooling Time	Weight	Box Quantity	Box Size (W X L X D)	Delivery Code
			mm	mm	mm					mm	
XBBKHF63X1.3	XBBKHA63X1.3	63mm x 1¼"	90	118	102	120	10	1.00	10	295 X 485 X 199	C
XBBKHF90X1.3	XBBKHA90X1.3	90mm x 1¼"	57	167	156	100	10	1.64	5	295 X 485 X 199	C
XBBKHF90X1.5	XBBKHA90X1.5	90mm x 1½"	57	167	156	100	10	1.60	5	295 X 485 X 199	C
XBBKHF90X2	XBBKHA90X2	90mm x 2"	57	167	156	100	10	1.38	5	295 X 485 X 199	C
XBBKHF110X1.3	XBBKHA110X1.3	110mm x 1¼"	56	166	180	120	10	1.96	6	295 X 485 X 199	C
XBBKHF110X1.5	XBBKHA110X1.5	110mm x 1½"	56	166	180	120	10	2.40	2	295 X 485 X 199	C
XBBKHF110X2	XBBKHA110X2	110mm x 2"	56	166	180	120	10	1.71	5	295 X 485 X 199	C
XBBKHF125X1.3	XBBKHA125X1.3	125mm x 1¼"	58	166	180	120	10	2.38	5	295 X 485 X 199	C
XBBKHF125X1.5	XBBKHA125X1.5	125mm x 1½"	58	166	180	120	10	2.34	5	295 X 485 X 199	C
XBBKHF125X2	XBBKHA125X2	125mm x 2"	58	166	180	120	10	1.64	5	295 X 485 X 199	C
XBBKHF160X1.3	XBBKHA160X1.3	160mm x 1¼"	84	215	236	120	10	2.83	5	295 X 485 X 333	C
XBBKHF160X1.5	XBBKHA160X1.5	160mm x 1½"	84	215	236	120	10	2.79	5	295 X 485 X 333	C
XBBKHF160X2	XBBKHA160X2	160mm x 2"	84	215	236	120	10	2.65	5	295 X 485 X 333	C
XBBKHF180X1.3	XBBKHA180X1.3	180mm x 1¼"	74	215	236	140	10	3.06	2	295 X 485 X 333	C
XBBKHF180X1.5	XBBKHA180X1.5	180mm x 1½"	74	215	236	140	10	3.03	2	295 X 485 X 333	C
XBBKHF180X2	XBBKHA180X2	180mm x 2"	74	215	236	140	10	2.60	2	295 X 485 X 333	C
XBBKHF200X2	XBBKHA200X2	200mm x 2"	82	166	263	120	10	2.17	2	295 X 485 X 333	C
XBBKHF225X2	XBBKHA225X2	225mm x 2"	80	166	300	120	10	2.30	2	295 X 485 X 333	C
XBBKHF250X2	XBBKHA250X2	250mm x 2"	86	166	317	120	10	2.42	2	295 X 485 X 333	C

Duckfoot Bend



- PE100
- Water PN16
- d90x90

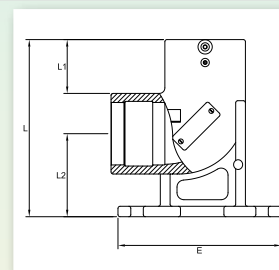

4mm Pin Fitting Code	4.7mm Pin Fitting Code	Fitting Size	L	L1	L2	E	Fusion Time	Cooling Time	Weight	Box Quantity	Box Size (W X L X D)	Delivery Code
			mm	mm	mm	mm					mm	
DFBBKHF90X90	DFBBKHA90X90	90 x 90deg	257	77	120	232	140	10	2.15	1	295 X 485 X 424	A

Duckfoot Bend Kit



- PE100
- Water PN16
- d63xDN80 - d180xDN80

Kit: E/F bend, E/F coupler and/or E/F reducer¹, spigot reducer¹, riser, flange gasket, backing ring², bolts², nuts², washers²

1. Spigot reducer and coupler in all kits except 90 x 80NP16
2. Rilsan coated

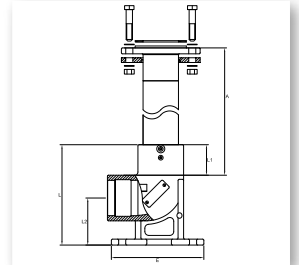

4mm Pin Fitting Code	4.7mm Pin Fitting Code	Fitting Size	L	L1	L2	A	E	Fusion Time	Cooling Time	Weight	Box Quantity	Box Size (W X L X D)	Delivery Code
			mm	mm	mm	mm	mm						
DFBKHF63X80KR	DFBBKA63X80KR	63 x 80NP16	257	77	120	455	232	140	10	6.96	1	295 X 485 X 333	A
DFBKHF90X80KR	DFBBKA90X80KR	90 x 80NP16	257	77	120	455	232	140	10	6.54	1	295 X 485 X 333	A
DFBKHF110X80KR	DFBBKA110X80KR	110 x 80NP16	257	77	120	455	232	140	10	7.63	1	295 X 485 X 333	A
DFBKHF125X80KR	DFBBKA125X80KR	125 x 80NP16	257	77	120	455	232	140	10	7.91	1	295 X 485 X 333	A
DFBKHF160X80KR	DFBBKA160X80KR	160 x 80NP16	257	77	120	455	232	140	10	10.33	1	295 X 485 X 424	A
DFBKHF180X80KR	DFBBKA180X80KR	180 x 80NP16	257	77	120	455	232	140	10	10.04	1	295 X 485 X 333	A

Hydrant Branch Saddle Kit



- PE100
- Water PN16
- d90xDN80 - d250xDN80

Kit: E/F hydrant branch saddle, coupler¹, riser, flange gasket, backing ring², bolts², nuts², washers²

1. Coupler in kit is 90mm
2. Rilsan coated

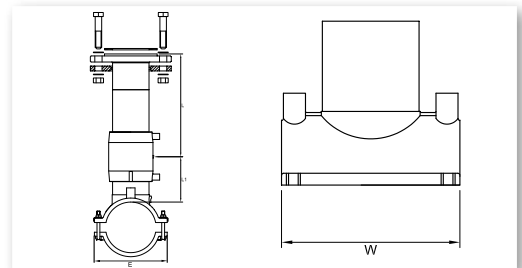

4mm Pin Fitting Code	4.7mm Pin Fitting Code	Fitting Size	L	L1	W	E	Fusion Time	Cooling Time	Weight	Box Quantity	Box Size (W X L X D)	Delivery Code
			mm	mm	mm	mm						
HBSHF90X80KRR	HBSHA90X80KRR	90 x 80K	455	124	144	154	100	10	5.64	1	295 X 485 X 333	C
HBSHF110X80KRR	HBSHA110X80KRR	110 x 80K	455	121	165	180	120	10	5.98	1	295 X 485 X 199	C
HBSHF125X80KRR	HBSHA125X80KRR	125 x 80K	455	114	165	180	120	10	5.90	1	295 X 485 X 199	C
HBSHF160X80KRR	HBSHA160X80KRR	160 x 80K	455	110	215	236	120	10	7.64	1	295 X 485 X 333	C
HBSHF180X80KRR	HBSHA180X80KRR	180 x 80K	455	100	215	236	120	10	6.69	1	295 X 485 X 333	C
HBSHF200X80KRR	HBSHA200X80KRR	200 x 80K	455	115	165	263	120	10	6.85	1	295 X 485 X 333	C
HBSHF225X80KRR	HBSHA225X80KRR	225 x 80K	455	112	165	291	120	10	6.94	1	295 X 485 X 333	C
HBSHF250X80KRR	HBSHA250X80KRR	250 x 80K	455	120	165	317	120	10	7.37	1	295 X 485 X 333	C

Stub Flange Kit



- PE100
- Water PN16
- d63xDN50 - d225xDN200

Kit: Coupler, stub flange, backing ring, gasket

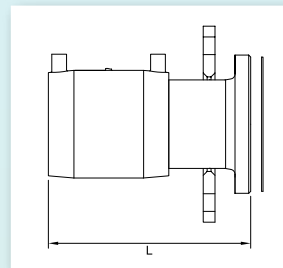

Fitting Code	Fitting Size	Coupler Size	L	Fusion Time	Cooling Time	Weight	Box Quantity	Box Size (W X L X D)	Delivery Code
	mm	mm		secs	mins			mm	
SFHK63K	63 x 50	63	181	80	5	2.07	1	295 X 486 X 199	C
SFHK90K	90 x 80	90	217	120	10	5.05	1	295 X 486 X 199	C
SFHK110K	110 x 100	110	246	200	10	4.77	1	295 X 486 X 199	C
SFHK125K	125 x 100	125	151	220	10	4.71	1	295 X 486 X 199	C
SFHK160K	160 x 150	160	269	180	10	9.71	1	295 X 486 X 333	C
SFHK180K	180 x 150	180	284	360	20	9.84	1	295 X 486 X 333	C
SFHK225K	225 X 200	225	310	600	30	16.22	1	295 X 486 X 333	C



SPIGOT FITTINGS

FOR GAS AND WATER



The Fusion range of spigot fittings is one of the most extensive in the world, with over 3,000 different product lines.

Fusion have a whole range of moulded, machined and butt welded spigots including elbows, bends, tees, stub flanges and many more in a range of different sizes and SDR's needed for polyethylene pipe jointing. Our spigot range allows for complicated yet high performance pipeline systems with a more diverse range of fittings than electrofusion, especially for larger diameter fittings.

Manufacturing

All Fusamatic branded spigots are manufactured from PE100 virgin polyethylene polymer supplied by recognised international market leaders such as Borealis and Ineos. All materials comply with the requirements of relevant standards including EN 12201 for drainage, sewerage and potable water, and EN 1555 for gas. The recommended temperature range for Fusamatic spigots is +5°C and +40°C with butt fusion jointing methods, or between -10°C and +40°C using Fusamatic electrofusion systems.

All Fusamatic branded spigot fittings are available with long spigot welding ends suitable for butt fusion and electrofusion on site; short spigot welding ends are also available for cost effective factory assembled fabrications.

Fusamatic branded spigots comply with the requirements of:

- EN 12201-3 Plastics piping systems for water supply, and for drainage and sewerage under pressure. Polyethylene (PE) Fittings.
- EN 1555-3 Plastics piping systems for the supply of gaseous fuels. Polyethylene (PE) Fittings.

International performance standards and regulations

Fusamatic branded spigots have the following international approvals:

- EN1555-3
- EN12201-3
- AS/NZS 4129 and ISO Type 5
- WRAS (UK)

Sizes

Note: SDR ratings, brand supplied and stated diameters are subject to availability.

Contact us for specific details on +44 (0)1246 268666 or via the website - www.fusiongroup.com

Backing Rings

Fusion are able to provide a range of backing rings for mechanical connections in galvanised, stainless and polypropylene coated steel.

These can be supplied drilled in accordance to local standards, but typically available in stock for EN 1092 - PN10, EN 1092 - PN16 and ANSI Class 150.

Other ancillary items such as gaskets and bolting sets can be provided upon request.

Applications

- Potable water mains, service pipes and house connections
- Gas transmission, distribution and house connections
- Wastewater systems including sewers
- Water and wastewater treatment plants
- Rain water and grey water collection
- Syphonic roof drainage
- Trenchless pipeline techniques including directional drilling
- Pumped slurry systems in mines and quarries
- Ducting for electrical, telecommunications and fibre optic cabling including subsea
- Open water and marine fish cages
- Industrial applications including process pipework and compressed air networks
- Agricultural irrigation

90° Elbow

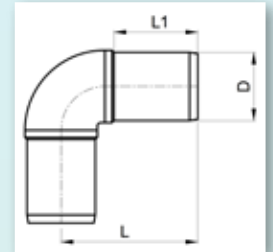

- PE100
- SDR 11 - Water PN16 / Gas 10 Bar
- SDR 17 - Water PN10 / Gas 6 Bar
- d20-500

Code	D	L	L1	Weight	Box Quantity	Delivery Code
	mm	mm	mm	Kg		
PE100 SDR 11 Water PN 16 Gas 10 Bar						
LSEHK20X90N	20	63	41	0.020	60	A
LSEHK25X90N	25	63	41	0.030	60	A
LSEHK32X90N	32	72	44	0.042	50	A
LSEHK40X90N	40	80	49	0.072	42	A
LSEHK50X90N	50	92	55	0.132	25	A
LSEHK63X90N	63	111	63	0.214	30	A
LSEHK75X90N	75	126	70	0.418	30	A
LSEHK90X90N	90	145	79	0.654	20	A
LSEHK110X90N	110	161	82	1.084	12	A
LSEHK125X90N	125	173	87	1.448	12	A
LSEHK140X90N	140	195	92	2.152	8	A
LSEHK160X90N	160	205	98	2.934	4	A
LSEHK180X90N	180	230	105	4.000	4	A
LSEHK200X90N	200	245	112	5.892	4	A
LSEHK225X90N	225	264	120	7.220	2	A
LSEHK250X90N	250	292	129	10.200	1	A
LSEHK280X90N	280	340	139	15.442	1	A
LSEHK315X90N	315	370	150	20.830	1	A
LSEHK355X90N	355	401	164	30.420	1	A
LSEHK400X90N	400	451	179	43.330	1	A
LSEHK450X90N	450	522	202	58.900	1	A
LSEHK500X90N	500	562	222	79.500	1	A
PE100 SDR 17 Water PN 10 Gas 6 Bar						
LSEHK50X90V	50	108	80	0.105	-	A
LSEHK63X90V	63	111	63	0.215	30	A
LSEHK75X90V	75	126	70	0.312	30	A
LSEHK90X90V	90	145	79	0.472	20	A
LSEHK110X90V	110	161	82	0.768	12	A
LSEHK125X90V	125	173	87	1.040	12	A
LSEHK140X90V	140	195	92	1.488	8	A
LSEHK160X90V	160	205	98	2.218	4	A
LSEHK180X90V	180	230	105	2.864	4	A
LSEHK200X90V	200	245	112	4.362	4	A
LSEHK225X90V	225	264	120	5.168	2	A
LSEHK250X90V	250	292	129	7.476	1	A
LSEHK280X90V	280	340	139	11.430	1	A
LSEHK315X90V	315	370	150	15.684	1	A
LSEHK355X90V	355	401	164	21.100	1	A
LSEHK400X90V	400	451	179	30.450	1	A
LSEHK450X90V	450	522	202	43.400	1	A
LSEHK500X90V	500	562	222	60.100	1	A

90° Elbow - Continued

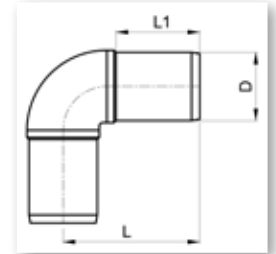

- PE100
- SDR 7.4 - Water PN25
- SDR 9 - Water PN20
- d25-500

Code	D mm	L mm	L1 mm	Weight Kg	Box Quantity	Delivery Code
PE100 SDR 7.4 Water PN 25						
LSEHK25X90T	25	-	-	-	100	B
LSEHK32X90T	32	-	-	-	60	B
LSEHK40X90T	40	88	56	0.110	60	B
LSEHK50X90T	50	90	57	0.180	46	B
LSEHK63X90T	63	112	67	0.380	70	B
LSEHK75X90T	75	127	72	0.570	32	B
LSEHK90X90T	90	150	82	0.960	24	B
LSEHK110X90T	110	167	90	1.560	15	B
LSEHK125X90T	125	178	91	2.210	8	B
LSEHK140X90T	140	192	96	3.130	6	B
LSEHK160X90T	160	209	104	4.300	5	B
LSEHK180X90T	180	209	107	4.300	4	B
LSEHK200X90T	200	250	117	7.700	40	B
LSEHK225X90T	225	265	122	9.280	28	B
LSEHK250X90T	250	294	131	14.740	20	B
LSEHK280X90T	280	322	126	20.200	14	B
LSEHK315X90T	315	350	153	27.900	9	B
LSEHK355X90T	355	375	165	34.200	8	B
LSEHK400X90T	400	424	185	48.620	1	B
LSEHK450X90T	450	-	-	-	1	B
LSEHK500X90T	500	-	-	-	1	B
PE100 SDR 9 Water PN 20						
LSEHK63X90R	63	112	67	0.360	70	B
LSEHK75X90R	75	127	72	0.050	32	B
LSEHK90X90R	90	150	82	0.910	24	B
LSEHK110X90R	110	167	90	1.480	15	B
LSEHK125X90R	125	178	91	2.100	8	B
LSEHK140X90R	140	192	96	2.970	6	B
LSEHK160X90R	160	209	104	4.100	5	B
LSEHK180X90R	180	223	107	5.040	4	B
LSEHK200X90R	200	250	117	7.320	40	B
LSEHK225X90R	225	265	122	8.820	28	B
LSEHK250X90R	250	294	131	14.000	20	B
LSEHK280X90R	280	322	126	19.190	14	B
LSEHK315X90R	315	350	153	26.510	9	B
LSEHK355X90R	355	375	165	32.490	8	B
LSEHK400X90R	400	424	185	46.190	1	B
LSEHK450X90R	450	-	-	-	1	B
LSEHK500X90R	500	-	-	-	1	B

45° Elbow

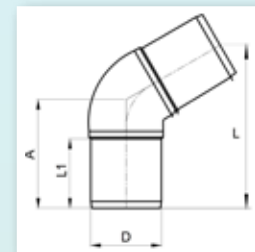

- PE100
- SDR 11 - Water PN16 / Gas 10 Bar
- SDR 17 - Water PN10 / Gas 6 Bar
- d20-500

Code	D mm	L mm	L1 mm	A mm	Weight Kg	Box Quantity	Delivery Code
PE100 SDR 11 Water PN 16 Gas 10 Bar							
LSEHK20X45N	20	119	41	70	0.027	60	A
LSEHK25X45N	25	125	41	73	0.036	50	A
LSEHK32X45N	32	136	44	79	0.057	50	A
LSEHK40X45N	40	145	49	85	0.099	32	A
LSEHK50X45N	50	153	55	89	0.136	62	A
LSEHK63X45N	63	160	63	93	0.211	42	A
LSEHK75X45N	75	176	70	102	0.329	30	A
LSEHK90X45N	90	202	79	118	0.560	24	A
LSEHK110X45N	110	220	82	128	0.951	18	A
LSEHK125X45N	125	239	87	139	1.290	12	A
LSEHK140X45N	140	250	92	145	1.693	12	A
LSEHK160X45N	160	273	98	159	2.398	9	A
LSEHK180X45N	180	290	105	168	3.233	4	A
LSEHK200X45N	200	311	112	179	4.451	4	A
LSEHK225X45N	225	341	120	198	5.815	2	A
LSEHK250X45N	250	368	129	213	7.908	2	A
LSEHK280X45N	280	406	139	235	11.255	1	A
LSEHK315X45N	315	430	150	249	14.170	1	A
LSEHK355X45N	355	490	164	284	22.530	1	A
LSEHK400X45N	400	548	179	317	32.020	1	A
LSEHK450X45N	450	-	202	375	44.000	1	A
LSEHK500X45N	500	-	222	410	57.000	1	A
PE100 SDR 17 Water PN 10 Gas 6 Bar							
LSEHK50X45V	50	-	61	76	0.084	-	A
LSEHK63X45V	63	160	63	93	0.164	42	A
LSEHK75X45V	75	176	70	102	0.239	30	A
LSEHK90X45V	90	202	79	118	0.410	24	A
LSEHK110X45V	110	220	82	128	0.689	18	A
LSEHK125X45V	125	239	87	139	0.906	12	A
LSEHK140X45V	140	250	92	145	1.201	12	A
LSEHK160X45V	160	273	98	159	1.764	9	A
LSEHK180X45V	180	290	105	168	2.283	4	A
LSEHK200X45V	200	311	112	179	3.276	4	A
LSEHK225X45V	225	341	120	198	4.215	2	A
LSEHK250X45V	250	368	129	213	5.908	2	A
LSEHK280X45V	280	406	139	235	8.055	1	A
LSEHK315X45V	315	430	150	249	10.270	1	A
LSEHK355X45V	355	490	164	284	15.470	1	A
LSEHK400X45V	400	548	179	317	21.920	1	A
LSEHK450X45V	450	-	202	375	33.000	1	A
LSEHK500X45V	500	-	222	410	42.800	1	A

45° Elbow - Continued



- PE100
- SDR 7.4 - Water PN25
- SDR 9 - Water PN20
- d40-500

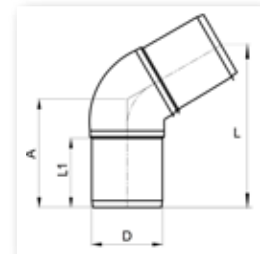

Code	D mm	L mm	L1 mm	A mm	Weight Kg	Box Quantity	Delivery Code
PE100 SDR 7.4 Water PN 25							
LSEHK40X45T	40	-	58	78	-	70	B
LSEHK50X45T	50	-	59	84	0.180	46	B
LSEHK63X45T	63	-	69	90	0.290	62	B
LSEHK75X45T	75	-	73	90	0.450	60	B
LSEHK90X45T	90	-	82	109	0.690	22	B
LSEHK110X45T	110	-	93	127	1.220	12	B
LSEHK125X45T	125	-	93	162	2.000	7	B
LSEHK140X45T	140	-	97	163	2.600	8	B
LSEHK160X45T	160	-	107	175	3.580	6	B
LSEHK180X45T	180	-	108	190	4.380	3	B
LSEHK200X45T	200	-	118	190	5.960	50	B
LSEHK225X45T	225	-	120	210	7.840	32	B
LSEHK250X45T	250	-	135	215	10.400	28	B
LSEHK280X45T	280	-	142	258	15.700	14	B
LSEHK315X45T	315	-	154	270	21.000	12	B
LSEHK355X45T	355	-	155	267	25.460	12	B
LSEHK400X45T	400	-	182	310	35.860	3	B
LSEHK450X45T	450	-	-	-	-	1	B
LSEHK500X45T	500	-	-	-	-	1	B
PE100 SDR 9 Water PN 20							
LSEHK63X45R	63	-	69	90	0.280	62	B
LSEHK75X45R	75	-	73	90	0.430	60	B
LSEHK90X45R	90	-	82	109	0.660	22	B
LSEHK110X45R	110	-	93	127	1.160	12	B
LSEHK125X45R	125	-	93	162	1.900	7	B
LSEHK140X45R	140	-	97	163	2.490	8	B
LSEHK160X45R	160	-	107	175	3.400	6	B
LSEHK180X45R	180	-	108	190	4.160	3	B
LSEHK200X45R	200	-	118	190	5.660	50	B
LSEHK225X45R	225	-	120	210	7.450	32	B
LSEHK250X45R	250	-	136	215	9.880	28	B
LSEHK280X45R	280	-	142	258	14.920	14	B
LSEHK315X45R	315	-	154	270	19.950	12	B
LSEHK355X45R	355	-	165	267	24.190	12	B
LSEHK400X45R	400	-	182	310	34.070	3	B
LSEHK450X45R	450	-	-	-	-	1	B
LSEHK500X45R	500	-	-	-	-	1	B

90° Multi Bend

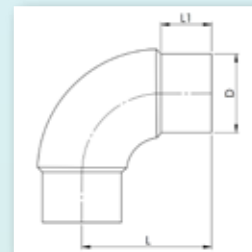

- PE100
- SDR 11 - Water PN16 / Gas 10 Bar
- SDR 17 - Water PN10 / Gas 6 Bar
- d32-315

Code	D	L	L1	Weight	Box Quantity	Delivery Code
	mm	mm	mm	Kg		
PE100 SDR 11 Water PN 16 Gas 10 Bar						
LSMBHK32X90N	32	79	48	0.043	1	B
LSMBHK40X90N	40	92	52	0.079	1	B
LSMBHK50X90N	50	107	59	0.147	1	B
LSMBHK63X90N	63	131	69	0.280	4	B
LSMBHK75X90N	75	153	76	0.460	16	B
LSMBHK90X90N	90	173	83	0.760	10	B
LSMBHK110X90N	110	195	84	1.297	6	B
LSMBHK125X90N	125	216	92	1.820	4	B
LSMBHK140X90N	140	237	96	2.445	5	B
LSMBHK160X90N	160	262	103	3.420	4	B
LSMBHK180X90N	180	294	115	4.980	6	B
LSMBHK200X90N	200	317	122	6.800	4	B
LSMBHK225X90N	225	351	131	9.200	2	B
LSMBHK250X90N	250	382	133	13.120	2	B
LSMBHK280X90N	280	432	153	18.335	1	B
LSMBHK315X90N	315	471	154	25.130	1	B
PE100 SDR 17 Water PN 10 Gas 6 Bar						
LSMBHK50X90V	50	108	59	0.132	1	B
LSMBHK63X90V	63	130	67	0.200	4	B
LSMBHK75X90V	75	153	76	0.345	16	B
LSMBHK90X90V	90	173	83	0.520	10	B
LSMBHK110X90V	110	195	84	0.945	6	B
LSMBHK125X90V	125	216	92	1.340	4	B
LSMBHK140X90V	140	237	97	1.760	5	B
LSMBHK160X90V	160	262	103	2.405	4	B
LSMBHK180X90V	180	290	113	3.390	6	B
LSMBHK200X90V	200	317	122	4.610	4	B
LSMBHK225X90V	225	350	130	6.410	2	B
LSMBHK250X90V	250	382	134	9.830	2	B
LSMBHK280X90V	280	430	154	13.710	1	B
LSMBHK315X90V	315	465	153	19.350	1	B

90° Bend - Short Spigot

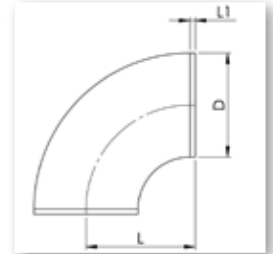

- PE100
- SDR 11 - Water PN16 / (Gas 10 Bar - Upon request)
- SDR 17 - Water PN10 / (Gas 6 Bar - Upon request)
- SDR 33 - Water PN5
- d20-500

Code	D	L	L1	Weight	Box Quantity	Delivery Code
	mm	mm	mm	Kg		
PE100 SDR 11 Water PN 16 (Gas 10 Bar - Upon request)						
SSEHK20X90N	20	38	18	0.009	300	B
SSEHK25X90N	25	32	5	0.010	10	B
SSEHK32X90N	32	37	6	0.020	10	B
SSEHK40X90N	40	44	8	0.030	10	B
SSEHK50X90N	50	51	10	0.070	5	B
SSEHK63X90N	63	66	12	0.140	5	B
SSEHK75X90N	75	87	14	0.250	2	B
SSEHK90X90N	90	100	15	0.350	2	B
SSEHK110X90N	110	118	15	0.690	2	B
SSEHK125X90N	125	138	15	1.050	1	B
SSEHK140X90N	140	155	20	1.450	1	B
SSEHK160X90N	160	178	25	1.980	1	B
SSEHK180X90N	180	195	25	2.830	1	B
SSEHK200X90N	200	210	20	3.910	1	B
SSEHK225X90N	225	236	25	5.400	1	B
SSEHK250X90N	250	279	30	7.260	1	B
SSEHK280X90N	280	316	40	10.500	1	B
SSEHK315X90N	315	352	40	14.600	1	B
SSEHK355X90N	355	380	38	20.825	1	B
SSEHK400X90N	400	434	41	31.435	1	B
SSEHK450X90N	450	450	50	38.3	1	B
SSEHK500X90N	500	450	50	47.3	1	B
PE100 SDR 17 Water PN 10 (Gas 6 Bar - Upon request)						
SSEHK50X90V	50	51	10	0.049	5	B
SSEHK63X90V	63	66	12	0.080	5	B
SSEHK75X90V	75	87	14	0.180	2	B
SSEHK90X90V	90	100	15	0.290	2	B
SSEHK110X90V	110	118	15	0.490	2	B
SSEHK125X90V	125	138	15	0.790	1	B
SSEHK140X90V	140	155	20	1.070	1	B
SSEHK160X90V	160	178	25	1.540	1	B
SSEHK180X90V	180	195	25	2.290	1	B
SSEHK200X90V	200	210	20	3.100	1	B
SSEHK225X90V	225	236	25	4.190	1	B
SSEHK250X90V	250	279	30	4.730	1	B
SSEHK280X90V	280	316	40	6.790	1	B
SSEHK315X90V	315	352	40	9.490	1	B
SSEHK355X90V	355	380	38	13.35	1	B
SSEHK400X90V	400	432	41	20.201	1	B
SSEHK450X90V	450	450	50	22.900	1	B
SSEHK500X90V	500	450	50	30.600	1	B
PE100 SDR 33 Water PN 5						
SSEHK110X90Y	110	138	28	0.215	10	C
SSEHK125X90Y	125	130	15	0.340	1	C
SSEHK140X90Y	140	175	35	0.460	1	C
SSEHK160X90Y	160	200	40	0.745	7	C
SSEHK180X90Y	180	200	8	1.240	1	C
SSEHK200X90Y	200	206	19	1.307	3	C
SSEHK225X90Y	225	236	21	2.240	1	C
SSEHK250X90Y	250	255	20	2.439	4	C
SSEHK280X90Y	280	290	24	4.440	1	C
SSEHK315X90Y	315	322	22	5.020	2	C
SSEHK355X90Y	355	380	15	9.000	1	C
SSEHK400X90Y	400	434	41	11.180	1	C

Seamless Bend 90°

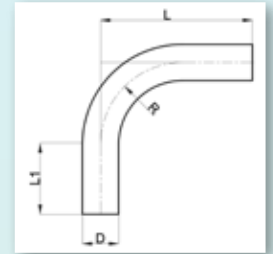

- PE100
- SDR 11 - Water PN16 / (Gas 10 Bar - Upon request)
- SDR 17 - Water PN10 / (Gas 6 Bar - Upon request)
- d32-900

Code	D	L	L1	R	Weight	Box Quantity	Delivery Code
	mm	mm	mm	mm	Kg		
PE100 SDR 11 Water PN 16 (Gas 10 Bar - Upon request)							
LRBHK32X90N	32	148	70	48	0.08	1	B
LRBHK40X90N	40	160	75	60	0.14	1	B
LRBHK50X90N	50	200	100	75	0.200	1	B
LRBHK63X90N	63	220	100	95	0.400	1	B
LRBHK75X90N	75	260	100	113	0.700	1	B
LRBHK90X90N	90	300	150	135	1.100	1	B
LRBHK110X90N	110	380	150	165	2.100	1	B
LRBHK125X90N	125	400	150	188	2.800	1	B
LRBHK140X90N	140	440	150	210	3.900	1	B
LRBHK160X90N	160	480	150	240	5.500	1	B
LRBHK180X90N	180	530	150	270	7.600	1	B
LRBHK200X90N	200	560	150	300	9.900	1	B
LRBHK225X90N	225	590	150	338	13.100	1	B
LRBHK250X90N	250	730	250	375	20.200	1	B
LRBHK280X90N	280	750	250	420	25.700	1	B
LRBHK315X90N	315	900	300	496	39.200	1	B
LRBHK355X90N	355	900	300	533	50.700	1	B
LRBHK400X90N	400	980	300	600	75.000	1	B
LRBHK450X90N	450	1070	300	675	97.000	1	B
LRBHK500X90N	500	1200	350	750	151.000	1	B
LRBHK560X90N	560	1290	350	840	176.000	1	B
LRBHK630X90N	630	1400	350	945	239.000	1	B
LRBHK710X90N	710	1900	350	1128	416.200	1	B
LRBHK800X90N	800	1550	400	1200	312.000	1	B
LRBHK900X90N	900	2200	400	1430	763.200	1	B
PE100 SDR 17 Water PN 10 (Gas 6 Bar - Upon request)							
LRBHK50X90V	50	200	100	75	0.200	1	B
LRBHK63X90V	63	220	100	95	0.300	1	B
LRBHK75X90V	75	260	100	113	0.500	1	B
LRBHK90X90V	90	300	150	135	0.700	1	B
LRBHK110X90V	110	380	150	165	1.400	1	B
LRBHK125X90V	125	400	150	188	1.900	1	B
LRBHK140X90V	140	440	150	210	2.600	1	B
LRBHK160X90V	160	480	150	240	3.700	1	B
LRBHK180X90V	180	530	150	270	5.200	1	B
LRBHK200X90V	200	560	150	300	6.700	1	B
LRBHK225X90V	225	590	150	338	8.800	1	B
LRBHK250X90V	250	730	250	375	13.600	1	B
LRBHK280X90V	280	750	250	420	17.400	1	B
LRBHK315X90V	315	900	300	496	26.500	1	B
LRBHK355X90V	355	900	300	533	41.220	1	B
LRBHK400X90V	400	980	300	600	49.700	1	B
LRBHK450X90V	450	1070	300	675	65.400	1	B
LRBHK500X90V	500	1200	350	750	88.000	1	B
LRBHK560X90V	560	1290	350	840	120.000	1	B
LRBHK630X90V	630	1400	350	945	169.000	1	B
LRBHK710X90V	710	1900	350	1128	281.100	1	B
LRBHK800X90V	800	2000	350	1274	371.400	1	B
LRBHK900X90V	900	2200	400	1430	515.200	1	B



Seamless Bend 60°

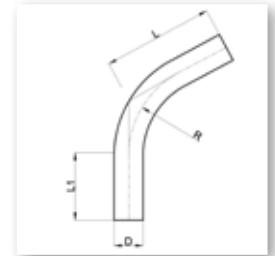

- PE100
- SDR 11 - Water PN16 / (Gas 10 Bar - Upon request)
- SDR17 - Water PN10 / (Gas 6 Bar - Upon request)
- d32-900

Code	D	L	L1	R	Weight	Box Quantity	Delivery Code
	mm	mm	mm	mm	Kg		
PE100 SDR 11 Water PN 16 (Gas 10 Bar - Upon request)							
LRBHK32X60N	32	128	70	48	0.100	1	B
LRBHK40X60N	40	135	75	60	0.120	1	B
LRBHK50X60N	50	170	100	75	0.200	1	B
LRBHK63X60N	63	180	100	95	0.300	1	B
LRBHK75X60N	75	220	100	113	0.600	1	B
LRBHK90X60N	90	250	150	135	1.000	1	B
LRBHK110X60N	110	280	150	165	1.600	1	B
LRBHK125X60N	125	300	150	188	2.300	1	B
LRBHK140X60N	140	350	150	210	3.300	1	B
LRBHK160X60N	160	380	150	240	4.700	1	B
LRBHK180X60N	180	410	150	270	6.400	1	B
LRBHK200X60N	200	430	150	300	8.300	1	B
LRBHK225X60N	225	450	150	338	10.900	1	B
LRBHK250X60N	250	570	250	375	17.100	1	B
LRBHK280X60N	280	580	250	420	21.700	1	B
LRBHK315X60N	315	690	300	496	32.800	1	B
LRBHK355X60N	355	760	300	560	45.700	1	B
LRBHK400X60N	400	780	300	637	59.400	1	B
LRBHK450X60N	450	820	300	711	78.900	1	B
LRBHK500X60N	500	960	350	783	114.200	1	B
LRBHK560X60N	560	980	350	877	145.500	1	B
LRBHK630X60N	630	1200	350	955	226.900	1	B
LRBHK710X60N	710	1450	350	1128	348.800	1	B
LRBHK800X60N	800	1250	400	1200	312.000	1	B
LRBHK900X60N	900	1650	400	1430	428.100	1	B
PE100 SDR 17 Water PN 10 (Gas 6 Bar - Upon request)							
LRBHK50X60V	50	170	100	75	0.100	1	B
LRBHK63X60V	63	180	100	95	0.200	1	B
LRBHK75X60V	75	220	100	113	0.400	1	B
LRBHK90X60V	90	250	150	135	0.700	1	B
LRBHK110X60V	110	280	150	165	1.100	1	B
LRBHK125X60V	125	300	150	188	1.500	1	B
LRBHK140X60V	140	350	150	210	2.200	1	B
LRBHK160X60V	160	380	150	240	3.200	1	B
LRBHK180X60V	180	410	150	270	4.300	1	B
LRBHK200X60V	200	430	150	300	5.600	1	B
LRBHK225X60V	225	450	150	338	7.400	1	B
LRBHK250X60V	250	570	250	375	11.500	1	B
LRBHK280X60V	280	580	250	420	14.700	1	B
LRBHK315X60V	315	690	300	496	22.200	1	B
LRBHK355X60V	355	760	300	560	31.000	1	B
LRBHK400X60V	400	780	300	637	40.100	1	B
LRBHK450X60V	450	820	300	711	53.300	1	B
LRBHK500X60V	500	960	350	783	77.300	1	B
LRBHK560X60V	560	930	350	840	98.200	1	B
LRBHK630X60V	630	1000	350	945	132.300	1	B
LRBHK710X60V	710	1450	350	1128	235.600	1	B
LRBHK800X60V	800	1500	350	1274	307.900	1	B
LRBHK900X60V	900	1650	400	1430	428.100	1	B

Seamless Bend 45°

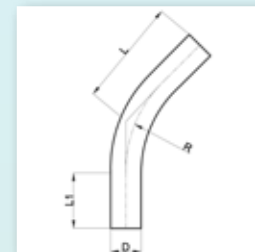

- PE100
- SDR 11 - Water PN16 / (Gas 10 Bar - Upon request)
- SDR 17 - Water PN10 / (Gas 6 Bar - Upon request)
- d32-900

Code	D	L	L1	R	Weight	Box Quantity	Delivery Code
	mm	mm	mm	mm	Kg		
PE100 SDR 11 Water PN 16 (Gas 10 Bar - Upon request)							
LRBHK32X45N	32	120	70	48	0.070	1	B
LRBHK40X45N	40	120	75	60	0.110	1	B
LRBHK50X45N	50	160	100	75	0.200	1	B
LRBHK63X45N	63	170	100	95	0.300	1	B
LRBHK75X45N	75	180	100	113	0.400	1	B
LRBHK90X45N	90	220	150	135	0.600	1	B
LRBHK110X45N	110	240	150	165	1.000	1	B
LRBHK125X45N	125	250	150	188	1.900	1	B
LRBHK140X45N	140	270	150	210	2.600	1	B
LRBHK160X45N	160	330	150	240	4.200	1	B
LRBHK180X45N	180	350	150	270	5.600	1	B
LRBHK200X45N	200	360	150	300	7.100	1	B
LRBHK225X45N	225	380	150	338	9.400	1	B
LRBHK250X45N	250	490	250	375	15.000	1	B
LRBHK280X45N	280	510	250	420	19.500	1	B
LRBHK315X45N	315	560	300	496	27.100	1	B
LRBHK355X45N	355	630	300	560	38.700	1	B
LRBHK400X45N	400	670	300	637	52.200	1	B
LRBHK450X45N	450	750	300	711	74.100	1	B
LRBHK500X45N	500	760	350	750	102.400	1	B
LRBHK560X45N	560	800	350	840	141.000	1	B
LRBHK630X45N	630	870	350	945	186.000	1	B
LRBHK710X45N	710	1300	350	1128	320.300	1	B
LRBHK800X45N	800	950	400	1200	312.000	1	B
LRBHK900X45N	900	1500	400	1430	592.300	1	B
PE100 SDR 17 Water PN 10 (Gas 6 Bar - Upon request)							
LRBHK50X45V	50	160	100	75	0.100	1	B
LRBHK63X45V	63	170	100	95	0.200	1	B
LRBHK75X45V	75	180	100	113	0.300	1	B
LRBHK90X45V	90	220	150	135	0.600	1	B
LRBHK110X45V	110	240	150	165	1.000	1	B
LRBHK125X45V	125	250	150	188	1.300	1	B
LRBHK140X45V	140	270	150	210	1.700	1	B
LRBHK160X45V	160	330	150	240	2.800	1	B
LRBHK180X45V	180	350	150	270	3.800	1	B
LRBHK200X45V	200	360	150	300	4.800	1	B
LRBHK225X45V	225	380	150	338	6.400	1	B
LRBHK250X45V	250	490	250	375	10.100	1	B
LRBHK280X45V	280	510	250	420	13.200	1	B
LRBHK315X45V	315	560	300	496	18.400	1	B
LRBHK355X45V	355	630	300	560	26.300	1	B
LRBHK400X45V	400	670	300	637	35.300	1	B
LRBHK450X45V	450	750	300	711	50.100	1	B
LRBHK500X45V	500	760	350	750	78.000	1	B
LRBHK560X45V	560	800	350	840	93.000	1	B
LRBHK630X45V	630	870	350	945	128.000	1	B
LRBHK710X45V	710	1300	350	1128	216.300	1	B
LRBHK800X45V	800	1400	350	1274	295.300	1	B
LRBHK900X45V	900	1500	400	1430	399.800	1	B
LRBHK800X45N	800	1500	480	1600	560.000	1	B
LRBHK900X45N	800	1500	400	1430	592.300	1	B

Seamless Bend 30°

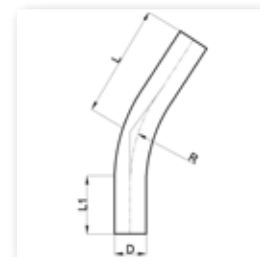

- PE100
- SDR 11 - Water PN16 / (Gas 10 Bar - Upon request)
- SDR 17 - Water PN10 / (Gas 6 Bar - Upon request)
- d32-900

Code	D	L	L1	R	Weight	Box Quantity	Delivery Code
	mm	mm	mm	mm	Kg		
PE100 SDR 11 Water PN 16 (Gas 10 Bar - Upon request)							
LRBHK32X30N	32	113	70	48	0.080	1	B
LRBHK40X30N	40	116	75	60	0.120	1	B
LRBHK50X30N	50	150	100	75	0.200	1	B
LRBHK63X30N	63	160	100	95	0.300	1	B
LRBHK75X30N	75	170	100	113	0.500	1	B
LRBHK90X30N	90	210	150	135	0.800	1	B
LRBHK110X30N	110	220	150	165	1.300	1	B
LRBHK125X30N	125	235	150	188	1.800	1	B
LRBHK140X30N	140	250	150	210	2.400	1	B
LRBHK160X30N	160	260	150	240	3.300	1	B
LRBHK180X30N	180	280	150	270	4.500	1	B
LRBHK200X30N	200	310	150	300	6.100	1	B
LRBHK225X30N	225	350	150	338	8.800	1	B
LRBHK250X30N	250	430	250	375	13.300	1	B
LRBHK280X30N	280	450	250	420	17.400	1	B
LRBHK315X30N	315	500	300	496	24.500	1	B
LRBHK355X30N	355	590	300	560	36.800	1	B
LRBHK400X30N	400	650	300	637	51.400	1	B
LRBHK450X30N	450	700	300	711	70.200	1	B
LRBHK500X30N	500	650	350	750	91.000	1	B
LRBHK560X30N	560	680	350	840	116.000	1	B
LRBHK630X30N	630	730	350	945	156.000	1	B
LRBHK710X30N	710	1150	350	1128	287.000	1	B
LRBHK800X30N	800	950	400	1200	312.000	1	B
LRBHK900X30N	900	1350	400	1430	540.700	1	B
PE100 SDR 17 Water PN 10 (Gas 6 Bar - Upon request)							
LRBHK50X30V	50	150	100	75	0.100	1	B
LRBHK63X30V	63	160	100	95	0.200	1	B
LRBHK75X30V	75	170	100	113	0.300	1	B
LRBHK90X30V	90	210	150	135	0.600	1	B
LRBHK110X30V	110	220	150	165	0.900	1	B
LRBHK125X30V	125	235	150	188	1.200	1	B
LRBHK140X30V	140	250	150	210	1.600	1	B
LRBHK160X30V	160	260	150	240	2.200	1	B
LRBHK180X30V	180	280	150	270	3.000	1	B
LRBHK200X30V	200	310	150	300	4.200	1	B
LRBHK225X30V	225	350	150	338	5.900	1	B
LRBHK250X30V	250	430	250	375	9.000	1	B
LRBHK280X30V	280	450	250	420	11.800	1	B
LRBHK315X30V	315	500	300	496	16.600	1	B
LRBHK355X30V	355	590	300	560	24.900	1	B
LRBHK400X30V	400	650	300	637	34.700	1	B
LRBHK450X30V	450	700	300	711	47.400	1	B
LRBHK500X30V	500	650	350	750	63.000	1	B
LRBHK560X30V	560	680	350	840	83.000	1	B
LRBHK630X30V	630	730	350	945	95.800	1	B
LRBHK710X30V	710	1150	350	1128	193.800	1	B
LRBHK800X30V	800	1250	350	1274	267.200	1	B
LRBHK900X30V	900	1350	400	1430	365.000	1	B

Seamless Bend 22°

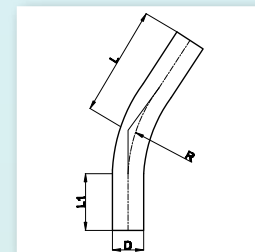

- PE100
- SDR 11 - Water PN16 / (Gas 10 Bar - Upon request)
- SDR 17 - Water PN10 / (Gas 6 Bar - Upon request)
- d32-900

Code	D	L	L1	R	Weight	Box Quantity	Delivery Code
	mm	mm	mm	mm	Kg		
PE100 SDR 11 Water PN 16 (Gas 10 Bar - Upon request)							
LRBHK32X22N	32	113	70	48	0.077	1	B
LRBHK40X22N	40	116	75	60	0.100	1	B
LRBHK50X22N	50	150	100	75	0.200	1	B
LRBHK63X22N	63	160	100	95	0.300	1	B
LRBHK75X22N	75	170	100	113	0.500	1	B
LRBHK90X22N	90	210	150	135	0.800	1	B
LRBHK110X22N	110	220	150	165	1.300	1	B
LRBHK125X22N	125	235	150	188	1.800	1	B
LRBHK140X22N	140	250	150	210	2.400	1	B
LRBHK160X22N	160	260	150	240	3.300	1	B
LRBHK180X22N	180	280	150	270	4.500	1	B
LRBHK200X22N	200	310	150	300	6.200	1	B
LRBHK225X22N	225	350	150	338	8.800	1	B
LRBHK250X22N	250	430	250	375	13.400	1	B
LRBHK280X22N	280	450	250	420	17.500	1	B
LRBHK315X22N	315	500	300	496	24.600	1	B
LRBHK355X22N	355	590	300	560	36.900	1	B
LRBHK400X22N	400	650	300	637	51.600	1	B
LRBHK450X22N	450	700	300	711	70.500	1	B
LRBHK500X22N	500	650	350	750	83.300	1	B
LRBHK560X22N	560	680	350	840	108.600	1	B
LRBHK630X22N	630	730	350	945	160.000	1	B
LRBHK710X22N	710	1150	350	1128	288.000	1	B
LRBHK800X22N	800	950	400	1200	312.000	1	B
LRBHK900X22N	900	1350	400	1430	366.400	1	B
PE100 SDR 17 Water PN 10 (Gas 6 Bar - Upon request)							
LRBHK50X22V	50	150	100	75	0.100	1	B
LRBHK63X22V	63	160	100	95	0.200	1	B
LRBHK75X22V	75	170	100	113	0.300	1	B
LRBHK90X22V	90	210	150	135	0.600	1	B
LRBHK110X22V	110	220	150	165	0.900	1	B
LRBHK125X22V	125	235	150	188	1.200	1	B
LRBHK140X22V	140	250	150	210	1.600	1	B
LRBHK160X22V	160	260	150	240	2.200	1	B
LRBHK180X22V	180	280	150	270	3.100	1	B
LRBHK200X22V	200	310	150	300	4.200	1	B
LRBHK225X22V	225	350	150	338	6.000	1	B
LRBHK250X22V	250	430	250	375	9.000	1	B
LRBHK280X22V	280	450	250	420	11.800	1	B
LRBHK315X22V	315	500	300	496	16.700	1	B
LRBHK355X22V	355	590	300	560	25.000	1	B
LRBHK400X22V	400	650	300	637	34.900	1	B
LRBHK450X22V	450	700	300	711	47.600	1	B
LRBHK500X22V	500	650	350	750	54.000	1	B
LRBHK560X22V	560	680	350	840	70.300	1	B
LRBHK630X22V	630	730	350	945	95.800	1	B
LRBHK710X22V	710	1150	350	1128	194.500	1	B
LRBHK800X22V	800	1250	350	1274	268.200	1	B
LRBHK900X22V	900	1350	400	1430	366.400	1	B

Seamless Bend 11°

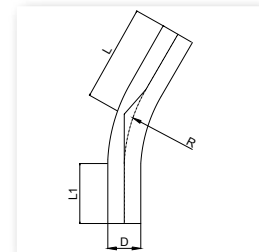

- PE100
- SDR 11 - Water PN16 / (Gas 10 Bar - Upon request)
- SDR 17 - Water PN10 / (Gas 6 Bar - Upon request)
- d32-900

Code	D	L	L1	R	Weight	Box Quantity	Delivery Code
	mm	mm	mm	mm	Kg		
PE100 SDR 11 Water PN 16 (Gas 10 Bar - Upon request)							
LRBHK32X11N	32	113	70	48	0.077	1	B
LRBHK40X11N	40	116	75	60	0.120	1	B
LRBHK50X11N	50	150	100	75	0.200	1	B
LRBHK63X11N	63	160	100	95	0.300	1	B
LRBHK75X11N	75	170	100	113	0.500	1	B
LRBHK90X11N	90	210	150	135	0.800	1	B
LRBHK110X11N	110	220	150	165	1.300	1	B
LRBHK125X11N	125	235	150	188	1.800	1	B
LRBHK140X11N	140	250	150	210	2.400	1	B
LRBHK160X11N	160	260	150	240	3.300	1	B
LRBHK180X11N	180	280	150	270	4.500	1	B
LRBHK200X11N	200	310	150	300	6.200	1	B
LRBHK225X11N	225	350	150	338	8.800	1	B
LRBHK250X11N	250	430	250	375	13.400	1	B
LRBHK280X11N	280	450	250	420	17.500	1	B
LRBHK315X11N	315	500	300	496	24.700	1	B
LRBHK355X11N	355	590	300	560	37.000	1	B
LRBHK400X11N	400	650	300	637	51.700	1	B
LRBHK450X11N	450	700	300	711	70.600	1	B
LRBHK500X11N	500	650	350	750	83.300	1	B
LRBHK560X11N	560	680	350	840	108.600	1	B
LRBHK630X11N	630	730	350	945	148.300	1	B
LRBHK710X11N	710	1150	350	1128	288.600	1	B
LRBHK800X11N	800	950	400	1200	312.000	1	B
LRBHK900X11N	900	1350	400	1430	544.100	1	B
PE100 SDR 17 Water PN 10 (Gas 6 Bar - Upon request)							
LRBHK50X11V	50	150	100	75	0.100	1	B
LRBHK63X11V	63	160	100	95	0.200	1	B
LRBHK75X11V	75	170	100	113	0.300	1	B
LRBHK90X11V	90	210	150	135	0.600	1	B
LRBHK110X11V	110	220	150	165	0.900	1	B
LRBHK125X11V	125	235	150	188	1.200	1	B
LRBHK140X11V	140	250	150	210	1.600	1	B
LRBHK160X11V	160	260	150	240	2.200	1	B
LRBHK180X11V	180	280	150	270	3.100	1	B
LRBHK200X11V	200	310	150	300	4.200	1	B
LRBHK225X11V	225	350	150	338	6.000	1	B
LRBHK250X11V	250	430	250	375	9.000	1	B
LRBHK280X11V	280	450	250	420	11.900	1	B
LRBHK315X11V	315	500	300	496	16.700	1	B
LRBHK355X11V	355	590	300	560	25.100	1	B
LRBHK400X11V	400	650	300	637	34.900	1	B
LRBHK450X11V	450	700	300	711	47.700	1	B
LRBHK500X11V	500	650	350	750	54.000	1	B
LRBHK560X11V	560	680	350	840	82.000	1	B
LRBHK630X11V	630	730	350	945	95.800	1	B
LRBHK710X11V	710	1150	350	1128	194.900	1	B
LRBHK800X11V	800	1250	350	1274	268.800	1	B
LRBHK900X11V	900	1350	400	1430	367.300	1	B

Seamless Bends - 90°, 60°, 45°, 30°, 22° & 11°

- PE100
- SDR 7.4 - Water PN25
- SDR9 upon request
- d110-315



Code	D	L	L1	R	Weight	Box Quantity	Delivery Code
	mm	mm	mm	mm	Kg		
PE100 SDR 7.4 Water PN 25							
LRBHK110X90T	110	340	150	165	2.720	1	C
LRBHK160X90T	160	415	150	240	7.160	1	C
LRBHK225X90T	225	513	150	338	16.370	1	C
LRBHK315X90T	315	803	250	473	53.000	1	C
LRBHK110X60T	110	270	150	165	2.383	1	C
LRBHK160X60T	160	313	150	240	7.155	1	C
LRBHK225X60T	225	370	150	338	13.952	1	C
LRBHK315X60T	315	612	250	473	50.670	1	C
LRBHK110X45T	110	243	150	165	2.113	1	C
LRBHK160X45T	160	274	150	240	6.678	1	C
LRBHK225X45T	225	315	150	338	12.970	1	C
LRBHK315X45T	315	535	250	473	41.600	1	C
LRBHK110X30T	110	219	150	165	2.473	1	C
LRBHK160X30T	160	239	150	240	6.678	1	C
LRBHK225X30T	225	266	150	338	11.912	1	C
LRBHK315X30T	315	460	250	473	37.400	1	C
LRBHK110X22T	110	219	150	165	2.473	1	C
LRBHK160X22T	160	239	150	240	6.678	1	C
LRBHK225X22T	225	266	150	338	11.912	1	C
LRBHK315X22T	315	460	250	473	37.400	1	C
LRBHK110X11T	110	219	150	165	2.473	1	C
LRBHK160X11T	160	239	150	240	6.678	1	C
LRBHK225X11T	225	266	150	338	11.912	1	C
LRBHK315X11T	315	460	250	473	37.400	1	C

Equal Tee

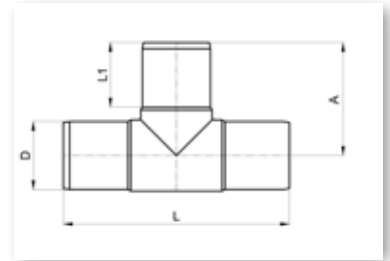

- PE100
- SDR 11 - Water PN16 / Gas 10 Bar
- SDR 17 - Water PN10 / Gas 6 Bar
- d20-630

Code	D mm	L mm	L1 mm	A mm	Weight Kg	Box Quantity	Delivery Code
PE100 SDR 11 Water PN 16 Gas 10 Bar							
LSETHK20N	20	148	41	74	0.038	50	A
LSETHK25N	25	158	41	78	0.054	40	A
LSETHK32N	32	166	44	84	0.074	30	A
LSETHK40N	40	188	49	96	0.134	50	A
LSETHK50N	50	229	55	114	0.242	47	A
LSETHK63N	63	216	63	107	0.384	36	A
LSETHK75N	75	261	70	130	0.560	22	A
LSETHK90N	90	290	79	142	0.892	14	A
LSETHK110N	110	327	82	162	1.580	14	A
LSETHK125N	125	356	87	178	2.204	8	A
LSETHK140N	140	380	92	189	2.751	6	A
LSETHK160N	160	417	98	208	4.130	4	A
LSETHK180N	180	458	105	225	5.658	3	A
LSETHK200N	200	481	112	236	7.490	2	A
LSETHK225N	225	527	120	260	10.126	2	A
LSETHK250N	250	590	129	292	13.768	2	A
LSETHK280N	280	690	139	340	21.564	1	A
LSETHK315N	315	712	150	352	27.066	1	A
LSETHK355N	355	789	164	394	36.830	1	A
LSETHK400N	400	877	179	439	55.760	1	A
LSETHK450N	450	984	195	470	80.000	2	A
LSETHK500N	500	1090	220	515	110.000	2	A
LSETHK560N	560	1230	240	565	146.000	1	A
LSETHK630N	630	1320	250	618	193.000	1	A
PE100 SDR 17 Water PN 10 Gas 6 Bar							
LSETHK50V	50	184	57	90	0.136	6	A
LSETHK63V	63	225	63	114	0.310	36	A
LSETHK75V	75	261	70	130	0.434	22	A
LSETHK90V	90	290	79	142	0.676	14	A
LSETHK110V	110	327	82	162	1.232	14	A
LSETHK125V	125	356	87	178	1.626	8	A
LSETHK140V	140	378	92	189	2.028	6	A
LSETHK160V	160	417	98	208	3.076	4	A
LSETHK180V	180	458	105	225	4.140	3	A
LSETHK200V	200	481	112	236	5.222	2	A
LSETHK225V	225	527	120	260	7.350	2	A
LSETHK250V	250	590	129	292	9.858	2	A
LSETHK280V	280	690	139	340	15.856	1	A
LSETHK315V	315	712	150	352	19.200	1	A
LSETHK355V	355	789	164	394	27.280	1	A
LSETHK400V	400	877	179	439	38.250	1	A
LSETHK450V	450	984	195	470	59.800	2	A
LSETHK500V	500	1090	220	515	78.200	2	A
LSETHK560V	560	1230	240	565	107.200	1	A
LSETHK630V	630	1320	250	618	144.800	1	A

Equal Tee - Continued

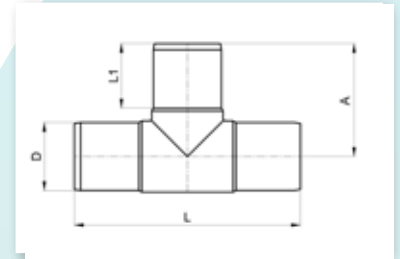

- PE100
- SDR 7.4 - Water PN25
- SDR 9 - Water PN20
- d25-630

Code	D mm	L mm	L1 mm	A mm	Weight Kg	Box Quantity	Delivery Code
PE100 SDR 7.4 Water PN 25							
LSETHK25T	25	-	-	-	-	50	B
LSETHK32T	32	-	-	-	-	30	B
LSETHK40T	40	-	-	-	-	44	B
LSETHK50T	50	180	56	-	0.230	30	B
LSETHK63T	63	229	68	-	0.520	44	B
LSETHK75T	75	256	72	-	0.800	28	B
LSETHK90T	90	303	82	-	1.360	16	B
LSETHK110T	110	336	92	-	2.240	7	B
LSETHK125T	125	356	91	-	2.980	5	B
LSETHK140T	140	390	96	-	4.180	4	B
LSETHK160T	160	423	104	-	6.360	48	B
LSETHK180T	180	451	107	-	7.780	35	B
LSETHK200T	200	501	117	-	10.600	29	B
LSETHK225T	225	538	121	-	14.270	20	B
LSETHK250T	250	596	131	-	19.740	14	B
LSETHK280T	280	651	127	-	27.180	10	B
LSETHK315T	315	703	152	-	40.000	7	B
LSETHK355T	355	800	165	-	52.200	6	B
LSETHK400T	400	890	180	-	66.000	4	B
LSETHK450T	450	984	195	-	92.600	2	B
LSETHK500T	500	1090	220	-	142.000	2	B
LSETHK560T	560	1230	240	-	205.000	1	B
LSETHK630T	630	1320	250	-	-	1	B
PE100 SDR 9 Water PN 20							
LSETHK75R	75	256	72	-	0.760	28	B
LSETHK90R	90	303	82	-	1.290	16	B
LSETHK110R	110	336	92	-	2.130	7	B
LSETHK125R	125	356	91	-	2.830	5	B
LSETHK140R	140	390	96	-	3.970	4	B
LSETHK160R	160	423	104	-	6.040	48	B
LSETHK180R	180	451	107	-	7.390	35	B
LSETHK200R	200	501	117	-	10.100	29	B
LSETHK225R	225	538	121	-	13.560	20	B
LSETHK250R	250	596	131	-	18.750	14	B
LSETHK280R	280	651	127	-	25.820	10	B
LSETHK315R	315	703	152	-	38.000	7	B
LSETHK355R	355	800	165	-	49.600	6	B
LSETHK400R	400	890	180	-	62.700	4	B
LSETHK450R	450	984	195	-	87.970	2	B
LSETHK500R	500	1090	220	-	134.900	2	B
LSETHK560R	560	1230	240	-	194.750	1	B
LSETHK630R	630	1320	250	-	-	1	B

Equal Tee - Short Spigot

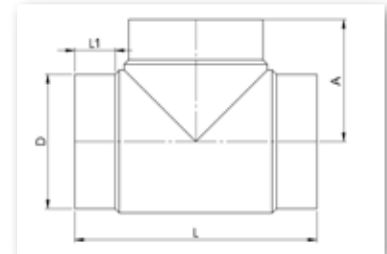

- PE100
- SDR 11 - Water PN16 / (Gas 10 Bar - Upon request)
- SDR17 - Water PN10 / (Gas 6 Bar - Upon request)
- SDR 33 - Water PN5
- d20-500

Code	D	L	L1	A	Weight	Box Quantity	Delivery Code
	mm	mm	mm	mm	Kg		
PE100 SDR 11 Water PN 16 (Gas 10 Bar - Upon request)							
SSETHK20N	20	76	11	38	0.021	90	C
SSETHK25N	25	84	11	40	0.030	50	C
SSETHK32N	32	87	11	42	0.046	30	C
SSETHK40N	40	90	11	45	0.067	25	C
SSETHK50N	50	100	12	50	0.115	10	C
SSETHK63N	63	135	17	67	0.251	30	C
SSETHK75N	75	153	19	75	0.394	16	C
SSETHK90N	90	198	43	99	0.705	10	C
SSETHK110N	110	254	55	127	1.260	6	C
SSETHK125N	125	254	52	125	1.638	4	C
SSETHK140N	140	314	65	153	2.690	5	C
SSETHK160N	160	322	58	161	3.380	4	C
SSETHK180N	180	430	94	214	5.740	2	C
SSETHK200N	200	438	90	219	7.280	3	C
SSETHK225N	225	452	76	226	9.615	3	C
SSETHK250N	250	450	68	227	10.770	3	C
SSETHK280N	280	530	87	265	15.950	1	C
SSETHK315N	315	570	88	285	21.285	1	C
SSETHK355N	355	698	103	349	31.505	1	C
SSETHK400N	400	730	105	363	40.570	1	C
SSETHK450N	450	837	137	419	47.000	1	C
SSETHK500N	500	930	159	465	89.000	1	C
PE100 SDR 17 Water PN 10 (Gas 6 Bar - Upon request)							
SSETHK50V	50	100	13	50	0.086	10	C
SSETHK63V	63	136	17	67	0.187	30	C
SSETHK75V	75	154	19	75	0.293	16	C
SSETHK90V	90	198	42	99	0.535	10	C
SSETHK110V	110	257	55	129	0.930	6	C
SSETHK125V	125	254	52	125	1.169	4	C
SSETHK140V	140	314	62	157	1.805	5	C
SSETHK160V	160	320	57	160	2.375	4	C
SSETHK180V	180	435	96	214	4.095	2	C
SSETHK200V	200	440	93	220	5.145	3	C
SSETHK225V	225	450	76	225	7.140	3	C
SSETHK250V	250	450	67	225	7.670	3	C
SSETHK280V	280	528	86	264	10.900	1	C
SSETHK315V	315	565	87	282	14.870	1	C
SSETHK355V	355	699	103	348	22.360	1	C
SSETHK400V	400	722	105	361	28.585	1	C
SSETHK450V	450	838	137	419	45.000	1	C
SSETHK500V	500	940	163	471	62.200	1	C
PE100 SDR 33 Water PN 5							
SSETHK110Y	110	215	30	105	0.700	1	C
SSETHK125Y	125	218	35	107	0.500	1	C
SSETHK140Y	140	253	20	125	1.400	1	C
SSETHK160Y	160	270	40	140	1.300	1	C
SSETHK180Y	180	310	45	150	1.400	1	C
SSETHK200Y	200	340	45	170	2.300	1	C
SSETHK225Y	225	440	48	220	4.000	1	C
SSETHK250Y	250	438	52	215	4.600	1	C
SSETHK280Y	280	500	65	243	7.800	1	C
SSETHK315Y	315	535	77	270	10.000	1	C
SSETHK355Y	355	674	96	347	13.500	1	C
SSETHK400Y	400	680	90	340	21.300	1	C

Reducing Tee

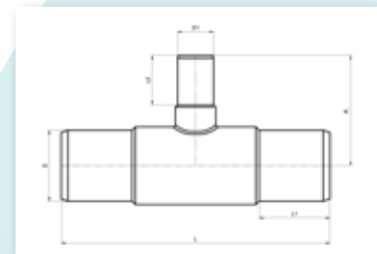

- PE100
- SDR 11 - Water PN16 / Gas 10 Bar
- d50x25 - 280x160

Code	D	L	L1	L2	A	Weight	Box Quantity	Delivery Code
	mm	mm	mm	mm	mm	Kg		
PE100 SDR 11 Water PN 16 Gas 10 Bar								
LSRTHK50X25N	50-25	229	55	41	85	0.180	32	B
LSRTHK50X32N	50-32	229	55	44	88	0.192	32	B
LSRTHK50X40N	50-40	229	55	49	94	0.210	32	B
LSRTHK63X32N	63-32	216	63	44	89	0.304	36	B
LSRTHK63X40N	63-40	216	63	49	95	0.312	36	B
LSRTHK63X50N	63-50	216	63	55	103	0.346	36	B
LSRTHK75X32N	75-32	260	70	44	100	0.450	22	B
LSRTHK75X40N	75-40	261	70	49	106	0.454	22	B
LSRTHK75X50N	75-50	261	70	55	113	0.480	22	B
LSRTHK75X63N	75-63	261	70	63	121	0.522	22	B
LSRTHK90X50N	90-50	290	79	55	124	0.748	14	B
LSRTHK90X63N	90-63	290	79	63	132	0.790	14	B
LSRTHK90X75N	90-75	290	79	70	136	0.834	14	B
LSRTHK110X50N	110-50	327	82	55	147	1.282	14	B
LSRTHK110X63N	110-63	327	82	63	149	1.318	14	B
LSRTHK110X75N	110-75	327	82	70	151	1.356	14	B
LSRTHK110X90N	110-90	327	82	79	157	1.422	14	B
LSRTHK125X63N	125-63	356	87	63	154	1.740	8	B
LSRTHK125X90N	125-90	356	87	79	172	2.000	8	B
LSRTHK125X110N	125-110	356	87	82	176	2.082	8	B
LSRTHK140X63N	140-63	390	97	72	-	2.510	4	B
LSRTHK140X90N	140-90	380	92	79	175	2.414	6	B
LSRTHK140X110N	140-110	380	92	82	179	2.542	6	B
LSRTHK140X125N	140-125	380	92	87	184	2.612	6	B
LSRTHK160X63N	160-63	417	98	63	175	3.430	5	B
LSRTHK160X75N	160-75	417	98	70	182	3.428	5	B
LSRTHK160X90N	160-90	417	98	79	187	3.334	5	B
LSRTHK160X110N	160-110	417	98	82	195	3.660	4	B
LSRTHK160X125N	160-125	417	98	87	200	3.754	4	B
LSRTHK180X63N	180-63	450	105	64	-	4.590	42	B
LSRTHK180X90N	180-90	458	105	79	206	4.818	3	B
LSRTHK180X110N	180-110	458	105	82	210	4.950	3	B
LSRTHK180X125N	180-125	458	105	87	215	5.086	3	B
LSRTHK180X160N	180-160	458	105	98	222	5.346	3	B
LSRTHK200X63N	200-63	481	112	63	191	6.170	3	B
LSRTHK200X90N	200-90	481	112	79	207	6.200	3	B
LSRTHK200X110N	200-110	481	112	82	211	6.324	3	B
LSRTHK200X125N	200-125	481	112	87	225	6.464	3	B
LSRTHK200X160N	200-160	481	112	98	227	6.820	3	B
LSRTHK200X180N	200-180	500	116	112	-	7.100	29	B
LSRTHK225X75N	225-75	560	129	73	219	9.750	3	B
LSRTHK225X90N	225-90	527	120	79	222	8.728	2	B
LSRTHK225X110N	225-110	527	120	82	226	8.750	2	B
LSRTHK225X125N	225-125	527	120	87	239	8.930	2	B
LSRTHK225X160N	225-160	527	120	98	242	9.120	2	B
LSRTHK225X180N	225-180	540	120	106	-	9.300	20	B
LSRTHK250X90N	250-90	590	129	79	243	11.428	2	B
LSRTHK250X110N	250-110	590	129	82	251	11.690	2	B
LSRTHK250X125N	250-125	590	129	87	252	11.630	2	B
LSRTHK250X160N	250-160	590	129	98	267	11.950	2	B
LSRTHK250X180N	250-180	596	130	106	-	12.620	16	B
LSRTHK250X200N	250-200	590	129	112	278	12.607	2	B
LSRTHK250X225N	250-225	590	129	120	285	13.264	2	B
LSRTHK280X110N	280-110	690	139	82	290	17.890	1	B
LSRTHK280X160N	280-160	690	139	98	302	18.186	1	B

Reducing Tee - Continued

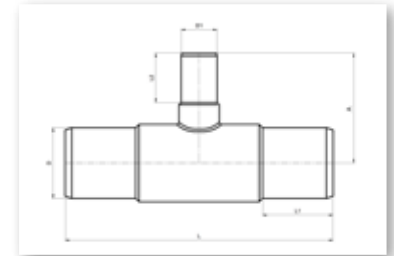

- PE100
- SDR 11 - Water PN16 / Gas 10 Bar
- SDR 17 - Water PN10 / Gas 6 Bar
- d63x50 - 630x250

Code	D	L	L1	L2	A	Weight	Box Quantity	Delivery Code
	mm	mm	mm	mm	mm	Kg		
PE100 SDR 11 Water PN 16 Gas 10 Bar								
LSRTHK280X200N	280-200	690	139	112	316	18.932	1	B
LSRTHK280X225N	280-225	690	139	120	320	19.700	1	B
LSRTHK280X250N	280-250	685	139	129	331	20.175	1	B
LSRTHK315X110N	315-110	712	150	82	293	22.746	1	B
LSRTHK315X125N	315-125	703	152	105	-	23.500	10	B
LSRTHK315X160N	315-160	712	150	98	303	23.860	1	B
LSRTHK315X180N	315-180	703	152	116	-	24.100	9	B
LSRTHK315X200N	315-200	712	150	112	317	24.300	1	B
LSRTHK315X225N	315-225	712	150	120	325	24.920	1	B
LSRTHK315X250N	315-250	712	150	129	332	25.420	1	B
LSRTHK355X110N	355-110	690	180	90	-	28.160	9	B
LSRTHK355X160N	355-160	685	180	101	-	27.800	8	B
LSRTHK355X225N	355-225	674	174	120	-	28.970	7	B
LSRTHK400X110N	400-110	755	190	89	-	38.400	6	B
LSRTHK400X160N	400-160	755	190	102	-	39.310	5	B
LSRTHK400X225N	400-225	755	190	120	-	50.200	5	B
LSRTHK450X315N	450-315	887	198	155	-	63.800	3	B
LSRTHK450X225N	450-225	765	198	122	-	53.000	4	B
LSRTHK450X160N	450-160	676	197	100	-	42.600	4	B
LSRTHK500X160N	500-160	710	215	99	-	55.200	4	B
LSRTHK500X250N	500-250	815	220	140	-	63.000	3	B
LSRTHK560X250N	560-250	960	240	135	-	95.000	2	B
LSRTHK630X160N	630-160	800	255	101	-	99.500	2	B
LSRTHK630X250N	630-250	875	255	137	-	103.000	2	B
PE100 SDR 17 Water PN 10 Gas 6 Bar								
LSRTHK63X50V	63-50	217	61	56	103	0.220	1	B
LSRTHK75X50V	75-50	252	68	56	109	0.410	1	B
LSRTHK75X63V	75-63	261	70	63	121	0.382	22	B
LSRTHK90X50V	90-50	302	81	58	-	0.710	20	B
LSRTHK90X63V	90-63	290	79	63	132	0.614	14	B
LSRTHK90X75V	90-75	290	79	70	136	0.612	14	B
LSRTHK110X50V	110-50	335	90	57	-	0.990	13	B
LSRTHK110X63V	110-63	327	82	63	149	1.020	14	B
LSRTHK110X75V	110-75	327	82	70	151	1.034	14	B
LSRTHK110X90V	110-90	327	82	79	157	1.100	14	B
LSRTHK125X63V	125-63	358	90	70	-	1.330	6	B
LSRTHK125X90V	125-90	356	87	79	172	1.420	8	B
LSRTHK125X110V	125-110	356	87	82	176	1.522	8	B
LSRTHK140X63V	140-63	390	97	72	-	2.160	3	B
LSRTHK140X90V	140-90	380	92	79	175	1.700	6	B
LSRTHK140X110V	140-110	380	92	82	179	1.816	6	B
LSRTHK140X125V	140-125	380	92	87	184	1.826	6	B
LSRTHK160X63V	160-63	417	98	63	175	2.536	5	B
LSRTHK160X75V	160-75	417	98	70	182	2.590	5	B
LSRTHK160X90V	160-90	417	98	79	187	2.642	5	B
LSRTHK160X110V	160-110	417	98	82	195	2.714	4	B
LSRTHK160X125V	160-125	417	98	87	200	2.742	4	B
LSRTHK180X63V	180-63	450	105	64	-	4.360	42	B
LSRTHK180X90V	180-90	458	105	79	206	3.540	3	B
LSRTHK180X110V	180-110	458	105	82	210	3.612	3	B
LSRTHK180X125V	180-125	458	105	87	215	3.682	3	B
LSRTHK180X160V	180-160	458	105	98	226	3.858	3	B
LSRTHK200X63V	200-63	481	112	63	191	4.427	3	B
LSRTHK200X90V	200-90	481	112	79	207	4.426	3	B
LSRTHK200X110V	200-110	481	112	82	211	4.545	3	B
LSRTHK200X125V	200-125	481	112	87	225	4.686	3	B

Reducing Tee - Continued

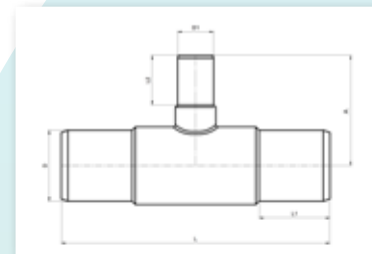

- PE100
- SDR 17 - Water PN10 / Gas 6 Bar
- d200x160 - 630x250

Code	D	L	L1	L2	A	Weight	Box Quantity	Delivery Code
	mm	mm	mm	mm	mm	Kg		
PE100 SDR 17 Water PN 10 Gas 6 Bar								
LSRTHK200X160V	200-160	481	112	98	227	4.854	3	B
LSRTHK200X180V	200-180	500	116	112	-	6.750	29	B
LSRTHK225X75V	225-75	561	129	72	219	7.060	3	B
LSRTHK225X90V	225-90	527	120	79	222	6.270	2	B
LSRTHK225X110V	225-110	527	120	82	226	6.344	2	B
LSRTHK225X125V	225-125	527	120	87	239	6.400	2	B
LSRTHK225X160V	225-160	527	120	98	242	6.652	2	B
LSRTHK225X180V	225-180	540	120	106	-	7.800	20	B
LSRTHK250X90V	250-90	590	129	79	243	8.550	2	B
LSRTHK250X110V	250-110	590	129	82	251	8.382	2	B
LSRTHK250X125V	250-125	590	129	87	252	8.500	2	B
LSRTHK250X160V	250-160	590	129	98	267	8.724	2	B
LSRTHK250X180V	250-180	596	130	109	-	9.560	16	B
LSRTHK250X200V	250-200	590	129	112	278	9.109	2	B
LSRTHK250X225V	250-225	590	129	120	285	9.494	2	B
LSRTHK280X110V	280-110	690	139	82	290	13.330	1	B
LSRTHK280X160V	280-160	690	139	98	302	13.650	1	B
LSRTHK280X200V	280-200	690	139	112	316	13.950	1	B
LSRTHK280X225V	280-225	690	139	120	320	14.160	1	B
LSRTHK280X250V	280-250	690	139	129	334	14.478	1	B
LSRTHK315X110V	315-110	712	150	82	293	16.234	1	B
LSRTHK315X125V	315-125	703	152	105	-	18.030	9	B
LSRTHK315X160V	315-160	712	150	98	303	16.430	1	B
LSRTHK315X180V	315-180	703	152	116	-	18.240	9	B
LSRTHK315X200V	315-200	712	150	112	317	16.750	1	B
LSRTHK315X225V	315-225	712	150	120	320	17.000	1	B
LSRTHK315X250V	315-250	712	150	129	332	17.640	1	B
LSRTHK355X110V	355-110	690	180	90	-	20.600	9	B
LSRTHK355X160V	355-160	685	180	101	-	20.940	8	B
LSRTHK355X225V	355-225	674	174	120	-	20.940	7	B
LSRTHK355X250V	355-250	685	175	130	-	21.400	7	B
LSRTHK400X110V	400-110	755	190	89	-	29.000	6	B
LSRTHK400X160V	400-160	755	190	102	-	29.100	5	B
LSRTHK400X225V	400-225	755	190	120	-	29.920	5	B
LSRTHK450X160V	450-160	676	197	100	-	31.800	4	B
LSRTHK450X225V	450-225	765	198	122	-	40.000	4	B
LSRTHK450X315V	450-315	887	198	155	-	48.000	3	B
LSRTHK500X160V	500-160	710	215	99	-	39.540	4	B
LSRTHK500X250V	500-250	960	240	135	-	46.400	3	B
LSRTHK560X250V	560-250	960	240	135	-	70.800	2	B
LSRTHK630X160V	630-160	800	255	101	-	66.200	2	B
LSRTHK630X250V	630-250	875	255	137	-	80.200	2	B



Reducing Tee - Continued

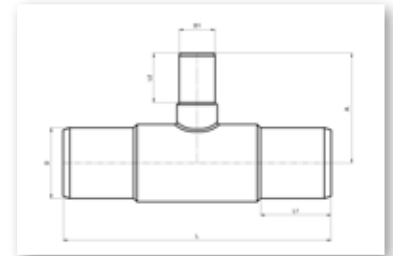

- PE100
- SDR 7.4 - Water PN25
- SDR 9 - Water PN20
- d250x160 - 560x250

Code	D mm	L mm	L1 mm	L2 mm	A mm	Weight Kg	Box Quantity	Delivery Code
PE100 SDR 7.4 Water PN 25								
LSRTHK250X160T	250-160	596	130	106	-	9.310	16	C
LSRTHK315X110T	315-110	703	156	91	-	17.440	1	C
LSRTHK315X160T	315-160	703	152	106	-	17.800	9	C
LSRTHK315X200T	315-200	703	152	120	-	18.000	1	C
LSRTHK355X160T	355-160	685	180	101	-	20.940	8	C
LSRTHK400X160T	400-160	755	190	102	-	29.100	5	C
LSRTHK400X225T	400-225	755	190	120	-	29.920	1	C
LSRTHK450X160T	450-160	676	197	100	-	31.800	1	C
LSRTHK450X225T	450-225	198	196	122	-	40.000	1	C
LSRTHK450X315T	450-315	887	196	155	-	48.000	1	C
LSRTHK560X250T	560-250	960	240	135	-	70.800	1	C
PE100 SDR 9 Water PN20								
LSRTHK250X160R	250-160	596	130	106	-	16.500	16	C
LSRTHK315X110R	315-110	703	156	91	-	29.000	10	C
LSRTHK315X160R	315-160	703	152	106	-	29.500	9	C
LSRTHK315X200R	315-200	703	152	120	-	29.500	9	C
LSRTHK355X160R	355-160	685	180	101	-	35.820	8	C
LSRTHK400X160R	400-160	755	190	102	-	49.610	5	C
LSRTHK400X225R	400-225	755	190	120	-	50.730	1	C
LSRTHK450X160R	450-160	676	197	100	-	49.600	1	C
LSRTHK450X225R	450-225	198	196	122	-	62.200	1	C
LSRTHK450X315R	450-315	887	196	155	-	74.600	1	C
LSRTHK560X250R	560-250	960	240	135	-	158.840	1	C

Reducing Tee - Short Spigot

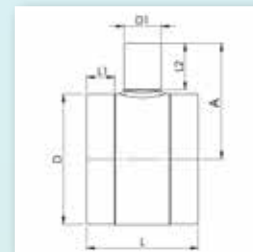

- PE100
- SDR 11 - Water PN16 / (Gas 10 Bar - Upon request)
- SDR 17 - Water PN10 / (Gas 6 Bar - Upon request)
- d90x32 - 180x125

Code	D-D1 mm	L mm	L1 mm	L2 mm	A mm	Weight Kg	Box Quantity	Delivery Code
PE100 SDR 11 Water PN 16 (Gas 10 Bar - Upon request)								
SSRTHK90X32N	90-32	203	53	23	85	0.560	1	C
SSRTHK110X32N	110-32	234	66	22	91	0.940	1	C
SSRTHK110X50N	110-50	240	66	27	101	0.950	1	C
SSRTHK125X63N	125-63	264	70	31	110	1.400	1	C
SSRTHK140X63N	140-63	291	83	32	120	1.800	1	C
SSRTHK140X75N	140-75	291	81	35	130	1.880	1	C
SSRTHK140X90N	140-90	291	81	41	130	1.920	1	C
SSRTHK140X110N	140-110	291	50	44	140	2.240	1	C
SSRTHK160X125N	160-125	315	58	47	150	2.690	1	C
SSRTHK180X63N	180-63	348	125	30	140	3.160	1	C
SSRTHK180X75N	180-75	348	112	30	160	3.350	1	C
SSRTHK180X125N	180-125	348	92	50	150	3.550	1	C
PE100 SDR 17 Water PN 10 (Gas 6 Bar - Upon request)								
SSRTHK140X63V	140-63	291	83	32	120	1.360	1	C
SSRTHK140X75V	140-75	291	81	35	130	1.370	1	C
SSRTHK140X90V	140-90	291	81	41	130	1.380	1	C
SSRTHK140X110V	140-110	291	50	44	140	1.660	1	C
SSRTHK160X125V	160-125	315	58	47	150	2.690	1	C
SSRTHK180X63V	180-63	348	125	30	140	2.200	1	C
SSRTHK180X75V	180-75	348	112	30	160	2.300	1	C
SSRTHK180X125V	180-125	348	92	50	150	2.500	1	C

Reducing and Equal Tee (Machined)

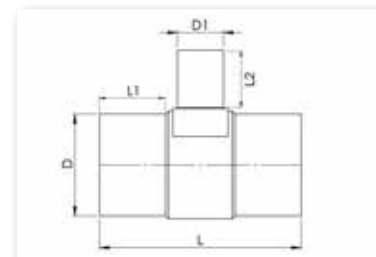

- PE100
- SDR 11 - Water PN16 / (Gas 10 Bar - Upon request)
- d250x63 - 450x200

Code	D-D1	L	L1	L2	Weight Kg	Box Quantity	Delivery Code
	mm	mm	mm	mm			
PE100 SDR 11 Water PN 16 (Gas 10 Bar - Upon request)							
MLSRTHK250X63N	250-63	676	250	150	11.700	1	C
MLSRTHK250X75N	250-75	691	250	150	12.100	1	C
MLSRTHK250X90N	250-90	706	250	150	12.600	1	C
MLSRTK250X110N	250-110	726	250	150	13.200	1	C
MLSRTK250X125N	250-125	741	250	150	13.700	1	C
MLSRTK250X140N	250-140	756	250	150	14.200	1	C
MLSRTK250X160N	250-160	777	250	150	15.000	1	C
MLSRTK250X180N	250-180	797	250	150	15.800	1	C
MLSRTK250X200N	250-200	817	250	150	16.600	1	C
MLSRTK250X225N	250-225	844	250	150	17.800	1	C
MLSRTHK280X63N	280-63	676	250	150	14.600	1	C
MLSRTHK280X75N	280-75	691	250	150	15.100	1	C
MLSRTHK280X90N	280-90	706	250	150	15.600	1	C
MLSRTK280X110N	280-110	726	250	150	16.300	1	C
MLSRTK280X125N	280-125	741	250	150	16.900	1	C
MLSRTK280X140N	280-140	756	250	150	17.500	1	C
MLSRTK280X160N	280-160	777	250	150	18.400	1	C
MLSRTK280X180N	280-180	797	250	150	19.300	1	C
MLSRTK280X200N	280-200	817	250	150	20.200	1	C
MLSRTK280X225N	280-225	844	250	150	21.500	1	C
MLSRTHK315X75N	315-75	791	300	150	21.400	1	C
MLSRTHK315X90N	315-90	806	300	150	22.000	1	C
MLSRTK315X110N	315-110	826	300	150	22.900	1	C
MLSRTK315X125N	315-125	841	300	150	23.500	1	C
MLSRTK315X140N	315-140	856	300	150	24.200	1	C
MLSRTK315X160N	315-160	877	300	150	25.200	1	C
MLSRTK315X180N	315-180	897	300	150	26.200	1	C
MLSRTK315X200N	315-200	917	300	150	27.300	1	C
MLSRTK315X225N	315-225	944	300	150	28.800	1	C
MLSRTK315X250N	315-250	967	300	250	31.700	1	C
MLSRTHK355X90N	355-90	806	300	150	27.800	1	C
MLSRTK355X110N	355-110	826	300	150	28.800	1	C
MLSRTK355X125N	355-125	841	300	150	29.600	1	C
MLSRTK355X140N	355-140	856	300	150	30.400	1	C
MLSRTK355X160N	355-160	877	300	150	31.600	1	C
MLSRTK355X180N	355-180	897	300	150	32.700	1	C
MLSRTK355X200N	355-200	917	300	150	34.000	1	C
MLSRTK355X225N	355-225	944	300	150	35.700	1	C
MLSRTK355X250N	355-250	967	300	250	38.800	1	C
MLSRTK355X280N	355-280	997	300	250	41.300	1	C
MLSRTK400X110N	400-110	826	300	150	36.100	1	C
MLSRTK400X125N	400-125	841	300	150	37.100	1	C
MLSRTK400X140N	400-140	856	300	150	38.000	1	C
MLSRTK400X160N	400-160	877	300	150	39.400	1	C
MLSRTK400X180N	400-180	897	300	150	40.800	1	C
MLSRTK400X200N	400-200	917	300	150	42.200	1	C
MLSRTK400X225N	400-225	944	300	150	44.100	1	C
MLSRTK400X250N	400-250	967	300	250	47.500	1	C
MLSRTK400X280N	400-280	997	300	250	50.300	1	C
MLSRTK400X315N	400-315	1032	300	300	55.100	1	C
MLSRTK450X125N	450-125	841	300	150	46.400	1	C
MLSRTK450X140N	450-140	856	300	150	47.600	1	C
MLSRTK450X160N	450-160	877	300	150	49.200	1	C
MLSRTK450X180N	450-180	897	300	150	50.800	1	C
MLSRTK450X200N	450-200	917	300	150	52.400	1	C

Reducing and Equal Tee (Machined) - Continued

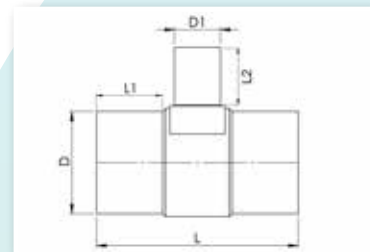

- PE100
- SDR 11 - Water PN16 / (Gas 10 Bar - Upon request)
- d450x225 - 900x900

Code	D-D1	L	L1	L2	Weight	Box Quantity	Delivery Code
	mm	mm	mm	mm	Kg		
PE100 SDR 11 Water PN 16 (Gas 10 Bar - Upon request)							
MLSRTK450X225N	450-225	944	300	150	54.700	1	C
MLSRTK450X250N	450-250	967	300	250	58.300	1	C
MLSRTK450X280N	450-280	997	300	250	61.500	1	C
MLSRTK450X315N	450-315	1032	300	300	66.600	1	C
MLSRTK450X355N	450-355	1072	300	300	71.700	1	C
MLSRTK500X140N	500-140	956	350	150	64.700	1	C
MLSRTK500X160N	500-160	977	350	150	66.600	1	C
MLSRTK500X180N	500-180	997	350	150	68.500	1	C
MLSRTK500X200N	500-200	1017	350	150	70.400	1	C
MLSRTK500X225N	500-225	1044	350	150	73.000	1	C
MLSRTK500X250N	500-250	1067	350	250	77.000	1	C
MLSRTK500X280N	500-280	1097	350	250	80.500	1	C
MLSRTK500X315N	500-315	1132	350	300	86.200	1	C
MLSRTK500X355N	500-355	1172	350	300	91.800	1	C
MLSRTK500X400N	500-400	1218	350	300	98.700	1	C
MLSRTK560X160N	560-160	1005	350	150	85.100	1	C
MLSRTK560X180N	560-180	1025	350	150	87.400	1	C
MLSRTK560X200N	560-200	1045	350	150	89.600	1	C
MLSRTK560X225N	560-225	1070	350	150	92.600	1	C
MLSRTK560X250N	560-250	1095	350	250	97.100	1	C
MLSRTK560X280N	560-280	1125	350	250	101.200	1	C
MLSRTK560X315N	560-315	1160	350	300	107.400	1	C
MLSRTK560X355N	560-355	1200	350	300	113.800	1	C
MLSRTK560X400N	560-400	1246	350	300	121.500	1	C
MLSRTK560X450N	560-450	1296	350	300	130.500	1	C
MLSETHK560N	560-560	1410	350	350	156.600	1	C
MLSRTK630X180N	630-180	1025	350	150	110.000	1	C
MLSRTK630X200N	630-200	1045	350	150	112.700	1	C
MLSRTK630X225N	630-225	1070	350	150	116.200	1	C
MLSRTK630X250N	630-250	1095	350	250	121.300	1	C
MLSRTK630X280N	630-280	1125	350	250	126.100	1	C
MLSRTK630X315N	630-315	1160	350	300	133.200	1	C
MLSRTK630X355N	630-355	1200	350	300	140.400	1	C
MLSRTK630X400N	630-400	1246	350	300	149.200	1	C
MLSRTK630X450N	630-450	1296	350	300	159.400	1	C
MLSRTK630X500N	630-500	1346	350	350	173.300	1	C
MLSETHK630N	630-630	1480	350	350	206.400	1	C
MLSRTK710X180N	710-180	1025	350	150	138.900	1	C
MLSRTK710X200N	710-200	1045	350	150	142.300	1	C
MLSRTK710X225N	710-225	1070	350	150	146.500	1	C
MLSRTK710X250N	710-250	1095	350	250	152.300	1	C
MLSRTK710X280N	710-280	1125	350	250	158.100	1	C
MLSRTK710X315N	710-315	1160	350	300	166.200	1	C
MLSRTK710X355N	710-355	1200	350	300	174.600	1	C
MLSRTK710X400N	710-400	1246	350	300	184.700	1	C
MLSRTK710X450N	710-450	1296	350	300	196.300	1	C
MLSRTK710X500N	710-500	1346	350	350	211.700	1	C
MLSRTK710X560N	710-560	1410	350	350	228.800	1	C
MLSETHK710N	710-710	1560	350	350	273.900	1	C
MLSETHK800N	800-800	1652	350	350	369.100	1	C
MLSETHK900N	900-900	1850	400	400	519.000	1	C

Reducing and Equal Tee (Machined) - Continued

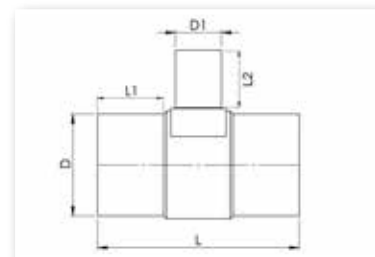

- PE100
- SDR 17 - Water PN10 / (Gas 5 Bar - Upon request)
- d250x63 - 450x200

Code	D-D1	L	L1	L2	Weight	Box Quantity	Delivery Code
	mm	mm	mm	mm	Kg		
PE100 SDR 17 Water PN 10 (Gas 5 Bar - Upon request)							
MLSRTHK250X63V	250-63	676	250	150	8.200	1	C
MLSRTHK250X75V	250-75	691	250	150	8.500	1	C
MLSRTHK250X90V	250-90	706	250	150	8.800	1	C
MLSRTK250X110V	250-110	726	250	150	9.300	1	C
MLSRTK250X125V	250-125	741	250	150	9.700	1	C
MLSRTK250X140V	250-140	756	250	150	10.100	1	C
MLSRTK250X160V	250-160	777	250	150	10.700	1	C
MLSRTK250X180V	250-180	797	250	150	11.300	1	C
MLSRTK250X200V	250-200	817	250	150	11.900	1	C
MLSRTK250X225V	250-225	844	250	150	12.800	1	C
MLSRTHK280X63V	280-63	676	250	150	10.300	1	C
MLSRTHK280X75V	280-75	691	250	150	10.700	1	C
MLSRTHK280X90V	280-90	706	250	150	11.100	1	C
MLSRTK280X110V	280-110	726	250	150	11.700	1	C
MLSRTK280X125V	280-125	741	250	150	12.100	1	C
MLSRTK280X140V	280-140	756	250	150	12.600	1	C
MLSRTK280X160V	280-160	777	250	150	13.200	1	C
MLSRTK280X180V	280-180	797	250	150	13.900	1	C
MLSRTK280X200V	280-200	817	250	150	14.600	1	C
MLSRTK280X225V	280-225	844	250	150	15.600	1	C
MLSRTHK315X75V	315-75	791	300	150	15.000	1	C
MLSRTHK315X90V	315-90	806	300	150	15.500	1	C
MLSRTK315X110V	315-110	826	300	150	16.200	1	C
MLSRTK315X125V	315-125	841	300	150	16.700	1	C
MLSRTK315X140V	315-140	856	300	150	17.200	1	C
MLSRTK315X160V	315-160	877	300	150	18.000	1	C
MLSRTK315X180V	315-180	897	300	150	18.700	1	C
MLSRTK315X200V	315-200	917	300	150	19.500	1	C
MLSRTK315X225V	315-225	944	300	150	20.700	1	C
MLSRTK315X250V	315-250	967	300	250	22.800	1	C
MLSRTHK355X90V	355-90	806	300	150	19.600	1	C
MLSRTK355X110V	355-110	826	300	150	20.400	1	C
MLSRTK355X125V	355-125	841	300	150	21.000	1	C
MLSRTK355X140V	355-140	856	300	150	21.600	1	C
MLSRTK355X160V	355-160	877	300	150	22.500	1	C
MLSRTK355X180V	355-180	897	300	150	23.400	1	C
MLSRTK355X200V	355-200	917	300	150	24.300	1	C
MLSRTK355X225V	355-225	944	300	150	25.600	1	C
MLSRTK355X250V	355-250	967	300	250	27.900	1	C
MLSRTK355X280V	355-280	997	300	250	29.700	1	C
MLSRTK400X110V	400-110	826	300	150	25.400	1	C
MLSRTK400X125V	400-125	841	300	150	26.100	1	C
MLSRTK400X140V	400-140	856	300	150	26.800	1	C
MLSRTK400X160V	400-160	877	300	150	27.900	1	C
MLSRTK400X180V	400-180	897	300	150	28.900	1	C
MLSRTK400X200V	400-200	917	300	150	29.900	1	C
MLSRTK400X225V	400-225	944	300	150	31.400	1	C
MLSRTK400X250V	400-250	967	300	250	33.900	1	C
MLSRTK400X280V	400-280	997	300	250	36.000	1	C
MLSRTK400X315V	400-315	1032	300	300	39.400	1	C
MLSRTK450X125V	450-125	841	300	150	32.600	1	C
MLSRTK450X140V	450-140	856	300	150	33.400	1	C
MLSRTK450X160V	450-160	877	300	150	34.600	1	C
MLSRTK450X180V	450-180	897	300	150	35.800	1	C
MLSRTK450X200V	450-200	917	300	150	37.100	1	C

Reducing and Equal Tee (Machined) - Continued

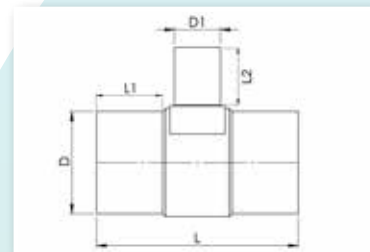

- PE100
- SDR 17 - Water PN10 / (Gas 5 Bar - Upon request)
- d450x225 - 1200x1200

Code	D-D1	L	L1	L2	Weight Kg	Box Quantity	Delivery Code
	mm	mm	mm	mm			
PE100 SDR 17 Water PN 10 Gas 5 Bar (Upon request)							
MLSRTK450X225V	450-225	944	300	150	38.800	1	C
MLSRTK450X250V	450-250	967	300	250	41.400	1	C
MLSRTK450X280V	450-280	997	300	250	43.800	1	C
MLSRTK450X315V	450-315	1032	300	300	47.600	1	C
MLSRTK450X355V	450-355	1072	300	300	51.300	1	C
MLSRTK500X140V	500-140	956	350	150	45.400	1	C
MLSRTK500X160V	500-160	977	350	150	46.800	1	C
MLSRTK500X180V	500-180	997	350	150	48.200	1	C
MLSRTK500X200V	500-200	1017	350	150	49.600	1	C
MLSRTK500X225V	500-225	1044	350	150	51.600	1	C
MLSRTK500X250V	500-250	1067	350	250	54.500	1	C
MLSRTK500X280V	500-280	1097	350	250	57.100	1	C
MLSRTK500X315V	500-315	1132	350	300	61.300	1	C
MLSRTK500X355V	500-355	1172	350	300	65.500	1	C
MLSRTK500X400V	500-400	1218	350	300	70.600	1	C
MLSRTK560X160V	560-160	1005	350	150	59.600	1	C
MLSRTK560X180V	560-180	1025	350	150	61.300	1	C
MLSRTK560X200V	560-200	1045	350	150	63.000	1	C
MLSRTK560X225V	560-225	1070	350	150	65.200	1	C
MLSRTK560X250V	560-250	1095	350	250	68.500	1	C
MLSRTK560X280V	560-280	1125	350	250	71.600	1	C
MLSRTK560X315V	560-315	1160	350	300	76.200	1	C
MLSRTK560X355V	560-355	1200	350	300	80.900	1	C
MLSRTK560X400V	560-400	1246	350	300	86.600	1	C
MLSRTK560X450V	560-450	1296	350	300	93.300	1	C
MLSETHK560V	560-560	1410	350	350	112.200	1	C
MLSRTK630X180V	630-180	1025	350	150	77.100	1	C
MLSRTK630X200V	630-200	1045	350	150	79.100	1	C
MLSRTK630X225V	630-225	1070	350	150	81.700	1	C
MLSRTK630X250V	630-250	1095	350	250	85.500	1	C
MLSRTK630X280V	630-280	1125	350	250	89.100	1	C
MLSRTK630X315V	630-315	1160	350	300	94.200	1	C
MLSRTK630X355V	630-355	1200	350	300	99.600	1	C
MLSRTK630X400V	630-400	1246	350	300	106.100	1	C
MLSRTK630X450V	630-450	1296	350	300	113.700	1	C
MLSRTK630X500V	630-500	1346	350	350	124.000	1	C
MLSETHK630V	630-630	1480	350	350	148.000	1	C
MLSRTK710X180V	710-180	1025	350	150	97.100	1	C
MLSRTK710X200V	710-200	1045	350	150	99.600	1	C
MLSRTK710X225V	710-225	1070	350	150	102.800	1	C
MLSRTK710X250V	710-250	1095	350	250	107.000	1	C
MLSRTK710X280V	710-280	1125	350	250	111.300	1	C
MLSRTK710X315V	710-315	1160	350	300	117.200	1	C
MLSRTK710X355V	710-355	1200	350	300	123.400	1	C
MLSRTK710X400V	710-400	1246	350	300	130.900	1	C
MLSRTK710X450V	710-450	1296	350	300	139.600	1	C
MLSRTK710X500V	710-500	1346	350	350	150.900	1	C
MLSRTK710X560V	710-560	1410	350	350	163.600	1	C
MLSETHK710V	710-710	1560	350	350	196.400	1	C
MLSETHK800V	800-800	1652	350	350	258.900	1	C
MLSETHK900V	900-900	1850	400	400	366.300	1	C
MLSETHK1000V	1000-1000	1955	400	400	474.100	1	C
MLSETHK1200V	1200-1200	2155	400	400	739.600	1	C

Reducing and Equal Tee - Short Spigot (Machined)

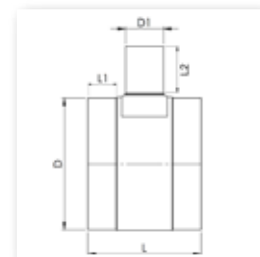

- PE100
- SDR 11 - Water PN16 / (Gas 10 Bar - Upon request)
- d280x63 - 500x225

Code	D-D1	L	L1	L2	Weight Kg	Box Quantity	Delivery Code
	mm	mm	mm	mm			
PE100 SDR 11 Water PN 16 (Gas 10 Bar - Upon request)							
MSSRTK280X63N	280-63	266	70	150	6.500	1	C
MSSRTK280X75N	280-75	281	70	150	6.900	1	C
MSSRTK280X90N	280-90	296	70	150	7.500	1	C
MSSRTK280X110N	280-110	316	70	150	8.200	1	C
MSSRTK280X125N	280-125	331	70	150	8.800	1	C
MSSRTK280X140N	280-140	346	70	150	9.400	1	C
MSSRTK280X160N	280-160	367	70	150	10.300	1	C
MSSRTK280X180N	280-180	387	70	150	11.200	1	C
MSSRTK280X200N	280-200	407	70	150	12.100	1	C
MSSRTK280X225N	280-225	434	70	150	13.400	1	C
MSSRTK315X110N	315-110	316	70	150	10.100	1	C
MSSRTK315X125N	315-125	331	70	150	10.700	1	C
MSSRTK315X140N	315-140	346	70	150	11.400	1	C
MSSRTK315X160N	315-160	367	70	150	12.400	1	C
MSSRTK315X180N	315-180	387	70	150	13.400	1	C
MSSRTK315X200N	315-200	407	70	150	14.500	1	C
MSSRTK315X225N	315-225	434	70	150	16.000	1	C
MSSRTK315X250N	315-250	457	70	250	18.900	1	C
MSSRTK315X75N	315-75	281	70	150	8.600	1	C
MSSRTK315X90N	315-90	296	70	150	9.200	1	C
MSSRTK355X90N	355-90	306	75	150	11.800	1	C
MSSRTK355X110N	355-110	326	75	150	12.800	1	C
MSSRTK355X125N	355-125	341	75	150	13.600	1	C
MSSRTK355X140N	355-140	356	75	150	14.400	1	C
MSSRTK355X160N	355-160	377	75	150	15.600	1	C
MSSRTK355X180N	355-180	397	75	150	16.800	1	C
MSSRTK355X200N	355-200	417	75	150	18.000	1	C
MSSRTK355X225N	355-225	444	75	150	19.700	1	C
MSSRTK355X250N	355-250	467	75	250	22.900	1	C
MSSRTK355X280N	355-280	497	75	250	25.400	1	C
MSSRTK400X110N	400-110	326	75	150	15.900	1	C
MSSRTK400X125N	400-125	341	75	150	16.800	1	C
MSSRTK400X140N	400-140	356	75	150	17.800	1	C
MSSRTK400X160N	400-160	377	75	150	19.200	1	C
MSSRTK400X180N	400-180	397	75	150	20.500	1	C
MSSRTK400X200N	400-200	417	75	150	21.900	1	C
MSSRTK400X225N	400-225	444	75	150	23.900	1	C
MSSRTK400X250N	400-250	467	75	250	27.300	1	C
MSSRTK400X280N	400-280	497	75	250	30.100	1	C
MSSRTK400X315N	400-315	532	75	300	34.800	1	C
MSSRTK450X125N	450-125	341	75	150	20.800	1	C
MSSRTK450X140N	450-140	356	75	150	21.900	1	C
MSSRTK450X160N	450-160	377	75	150	23.500	1	C
MSSRTK450X180N	450-180	397	75	150	25.100	1	C
MSSRTK450X200N	450-200	417	75	150	26.800	1	C
MSSRTK450X225N	450-225	444	75	150	29.000	1	C
MSSRTK450X250N	450-250	467	75	250	32.700	1	C
MSSRTK450X280N	450-280	497	75	250	35.800	1	C
MSSRTK450X315N	450-315	532	75	300	41.000	1	C
MSSRTK450X355N	450-355	572	75	300	46.100	1	C
MSSRTK500X140N	500-140	356	75	150	26.700	1	C
MSSRTK500X160N	500-160	377	75	150	28.600	1	C
MSSRTK500X180N	500-180	397	75	150	30.500	1	C
MSSRTK500X200N	500-200	417	75	150	32.400	1	C
MSSRTK500X225N	500-225	444	75	150	35.100	1	C

Reducing and Equal Tee - Short Spigot (Machined) - Continued

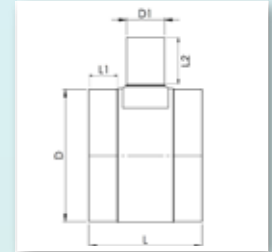

- PE100
- SDR 11 - Water PN16 / (Gas 10 Bar - Upon request)
- d500x250 - 900x900

Code	D-D1	L	L1	L2	Weight	Box Quantity	Delivery Code
	mm	mm	mm	mm	Kg		
PE100 SDR 11 Water PN 16 (Gas 10 Bar - Upon request)							
MSSRTK500X250N	500-250	467	75	250	39.000	1	C
MSSRTK500X280N	500-280	497	75	250	42.500	1	C
MSSRTK500X315N	500-315	532	75	300	48.200	1	C
MSSRTK500X355N	500-355	572	75	300	53.800	1	C
MSSRTK500X400N	500-400	618	75	300	60.700	1	C
MSSRTK560X160N	560-160	375	75	150	35.200	1	C
MSSRTK560X180N	560-180	395	75	150	37.400	1	C
MSSRTK560X200N	560-200	415	75	150	39.700	1	C
MSSRTK560X225N	560-225	440	75	150	42.600	1	C
MSSRTK560X250N	560-250	465	75	250	47.100	1	C
MSSRTK560X280N	560-280	495	75	250	51.200	1	C
MSSRTK560X315N	560-315	530	75	300	57.500	1	C
MSSRTK560X355N	560-355	570	75	300	63.800	1	C
MSSRTK560X400N	560-400	616	75	300	71.500	1	C
MSSRTK560X450N	560-450	666	75	300	80.600	1	C
MSSETHK560N	560-560	780	75	350	106.600	1	C
MSSRTK630X180N	630-180	395	75	150	46.700	1	C
MSSRTK630X200N	630-200	415	75	150	49.400	1	C
MSSRTK630X225N	630-225	440	75	150	52.900	1	C
MSSRTK630X250N	630-250	465	75	250	58.100	1	C
MSSRTK630X280N	630-280	495	75	250	62.800	1	C
MSSRTK630X315N	630-315	530	75	300	69.900	1	C
MSSRTK630X355N	630-355	570	75	300	77.200	1	C
MSSRTK630X400N	630-400	616	75	300	85.900	1	C
MSSRTK630X450N	630-450	666	75	300	96.100	1	C
MSSRTK630X500N	630-500	716	75	350	110.100	1	C
MSSETHK630N	630-630	850	75	350	143.100	1	C
MSSRTK710X180N	710-180	395	75	150	58.500	1	C
MSSRTK710X200N	710-200	415	75	150	61.800	1	C
MSSRTK710X225N	710-225	440	75	150	66.100	1	C
MSSRTK710X250N	710-250	465	75	250	72.000	1	C
MSSRTK710X280N	710-280	495	75	250	77.700	1	C
MSSRTK710X315N	710-315	533	75	300	86.200	1	C
MSSRTK710X355N	710-355	570	75	300	94.200	1	C
MSSRTK710X400N	710-400	616	75	300	104.300	1	C
MSSRTK710X450N	710-450	666	75	300	115.900	1	C
MSSRTK710X500N	710-500	716	75	350	131.300	1	C
MSSRTK710X560N	710-560	780	75	350	148.400	1	C
MSSETHK710N	710-710	930	75	350	193.600	1	C
MSSETHK800N	800-800	1032	80	350	267.300	1	C
MSSETHK900N	900-900	1150	80	400	370.800	1	C

Reducing and Equal Tee - Short Spigot (Machined) - Continued

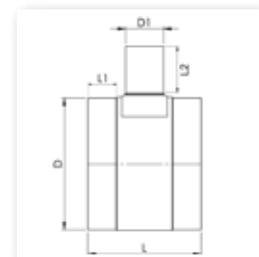

- PE100
- SDR 17 - Water PN10 / (Gas 5 Bar - Upon request)
- d280x63 - 500x225

Code	D-D1	L	L1	L2	Weight Kg	Box Quantity	Delivery Code
	mm	mm	mm	mm			
PE100 SDR 17 Water PN 10 (Gas 5 Bar - Upon request)							
MSSRTK280X63V	280-63	266	70	150	4.700	1	C
MSSRTK280X75V	280-75	281	70	150	5.100	1	C
MSSRTK280X90V	280-90	296	70	150	5.500	1	C
MSSRTK280X110V	280-110	316	70	150	6.000	1	C
MSSRTK280X125V	280-125	331	70	150	6.500	1	C
MSSRTK280X140V	280-140	346	70	150	6.900	1	C
MSSRTK280X160V	280-160	367	70	150	7.600	1	C
MSSRTK280X180V	280-180	387	70	150	8.300	1	C
MSSRTK280X200V	280-200	407	70	150	9.000	1	C
MSSRTK280X225V	280-225	434	70	150	10.000	1	C
MSSRTK315X75V	315-75	281	70	150	6.200	1	C
MSSRTK315X90V	315-90	296	70	150	6.700	1	C
MSSRTK315X110V	315-110	316	70	150	7.400	1	C
MSSRTK315X125V	315-125	331	70	150	7.800	1	C
MSSRTK315X140V	315-140	346	70	150	8.400	1	C
MSSRTK315X160V	315-160	367	70	150	9.100	1	C
MSSRTK315X180V	315-180	387	70	150	9.900	1	C
MSSRTK315X200V	315-200	407	70	150	10.700	1	C
MSSRTK315X225V	315-225	434	70	150	11.800	1	C
MSSRTK315X250V	315-250	457	70	250	13.900	1	C
MSSRTK355X90V	355-90	306	75	150	8.600	1	C
MSSRTK355X110V	355-110	326	75	150	9.400	1	C
MSSRTK355X125V	355-125	341	75	150	10.000	1	C
MSSRTK355X140V	355-140	356	75	150	10.600	1	C
MSSRTK355X160V	355-160	377	75	150	11.500	1	C
MSSRTK355X180V	355-180	397	75	150	12.400	1	C
MSSRTK355X200V	355-200	417	75	150	13.300	1	C
MSSRTK355X225V	355-225	444	75	150	14.600	1	C
MSSRTK355X250V	355-250	467	75	250	16.800	1	C
MSSRTK355X280V	355-280	497	75	250	18.700	1	C
MSSRTK400X110V	400-110	326	75	150	11.500	1	C
MSSRTK400X125V	400-125	341	75	150	12.200	1	C
MSSRTK400X140V	400-140	356	75	150	12.900	1	C
MSSRTK400X160V	400-160	377	75	150	13.900	1	C
MSSRTK400X180V	400-180	397	75	150	15.000	1	C
MSSRTK400X200V	400-200	417	75	150	16.000	1	C
MSSRTK400X225V	400-225	444	75	150	17.500	1	C
MSSRTK400X250V	400-250	467	75	250	19.900	1	C
MSSRTK400X280V	400-280	497	75	250	22.000	1	C
MSSRTK400X315V	400-315	532	75	300	25.400	1	C
MSSRTK450X125V	450-125	341	75	150	15.000	1	C
MSSRTK450X140V	450-140	356	75	150	15.800	1	C
MSSRTK450X160V	450-160	377	75	150	17.000	1	C
MSSRTK450X180V	450-180	397	75	150	18.200	1	C
MSSRTK450X200V	450-200	417	75	150	19.400	1	C
MSSRTK450X225V	450-225	444	75	150	21.100	1	C
MSSRTK450X250V	450-250	467	75	250	23.700	1	C
MSSRTK450X280V	450-280	497	75	250	26.100	1	C
MSSRTK450X315V	450-315	532	75	300	29.800	1	C
MSSRTK450X355V	450-355	572	75	300	33.600	1	C
MSSRTK500X140V	500-140	356	75	150	19.300	1	C
MSSRTK500X160V	500-160	377	75	150	20.700	1	C
MSSRTK500X180V	500-180	397	75	150	22.100	1	C
MSSRTK500X200V	500-200	417	75	150	23.500	1	C
MSSRTK500X225V	500-225	444	75	150	25.500	1	C

Reducing and Equal Tee - Short Spigot (Machined) - Continued

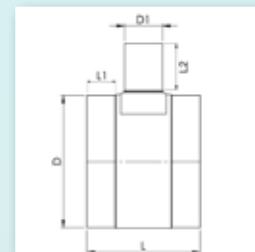

- PE100
- SDR 17 - Water PN10 / (Gas 5 Bar - Upon request)
- d500x250 - 1200x1200

Code	D-D1	L	L1	L2	Weight	Box Quantity	Delivery Code
	mm	mm	mm	mm	Kg		
PE100 SDR 17 Water PN 10 (Gas 5 Bar - Upon request)							
MSSRTK500X250V	500-250	467	75	250	28.300	1	C
MSSRTK500X280V	500-280	497	75	250	31.000	1	C
MSSRTK500X315V	500-315	532	75	300	35.100	1	C
MSSRTK500X355V	500-355	572	75	300	39.200	1	C
MSSRTK500X400V	500-400	618	75	300	44.300	1	C
MSSRTK560X160V	560-160	375	75	150	25.300	1	C
MSSRTK560X180V	560-180	395	75	150	27.000	1	C
MSSRTK560X200V	560-200	415	75	150	28.700	1	C
MSSRTK560X225V	560-225	440	75	150	30.900	1	C
MSSRTK560X250V	560-250	465	75	250	34.100	1	C
MSSRTK560X280V	560-280	495	75	250	37.200	1	C
MSSRTK560X315V	560-315	530	75	300	41.700	1	C
MSSRTK560X355V	560-355	570	75	300	46.400	1	C
MSSRTK560X400V	560-400	616	75	300	52.100	1	C
MSSRTK560X450V	560-450	666	75	300	58.800	1	C
MSSETHK560V	560-560	780	75	350	77.500	1	C
MSSRTK630X180V	630-180	395	75	150	33.600	1	C
MSSRTK630X200V	630-200	415	75	150	35.600	1	C
MSSRTK630X225V	630-225	440	75	150	38.200	1	C
MSSRTK630X250V	630-250	465	75	250	41.900	1	C
MSSRTK630X280V	630-280	495	75	250	45.500	1	C
MSSRTK630X315V	630-315	530	75	300	50.600	1	C
MSSRTK630X355V	630-355	570	75	300	56.000	1	C
MSSRTK630X400V	630-400	616	75	300	62.400	1	C
MSSRTK630X450V	630-450	666	75	300	70.000	1	C
MSSRTK630X500V	630-500	716	75	350	80.100	1	C
MSSETHK630V	630-630	850	75	350	104.000	1	C
MSSRTK710X180V	710-180	395	75	150	41.900	1	C
MSSRTK710X200V	710-200	415	75	150	44.400	1	C
MSSRTK710X225V	710-225	440	75	150	47.500	1	C
MSSRTK710X250V	710-250	465	75	250	51.800	1	C
MSSRTK710X280V	710-280	495	75	250	56.000	1	C
MSSRTK710X315V	710-315	533	75	300	62.200	1	C
MSSRTK710X355V	710-355	570	75	300	68.100	1	C
MSSRTK710X400V	710-400	616	75	300	75.500	1	C
MSSRTK710X450V	710-450	666	75	300	84.100	1	C
MSSRTK710X500V	710-500	716	75	350	95.300	1	C
MSSRTK710X560V	710-560	780	75	350	107.900	1	C
MSSETHK710V	710-710	930	75	350	140.600	1	C
MSSETHK800V	800-800	1032	80	350	191.200	1	C
MSSETHK900V	900-900	1130	80	400	266.800	1	C
MSSETHK1000V	1000-1000	1235	80	400	351.500	1	C
MSSETHK1200V	1200-1200	1435	80	400	563.000	1	C

Reducing Tee Eccentric Level Invert (Machined)

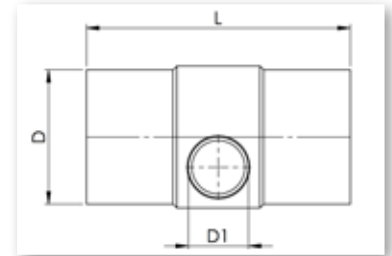

- PE100
- SDR 11 - Water PN16 (Gas 10 Bar - Upon request)
- d280x63 - 500x225

Code	D-D1	L	Weight	Box Quantity	Delivery Code
	mm	mm	Kg		
PE100 SDR 11 Water PN 16 (Gas 10 Bar - Upon request)					
MLIRTHK280X63N	280-63	690	15.400	1	C
MLIRTHK280X75N	280-75	705	15.900	1	C
MLIRTHK280X90N	280-90	720	16.400	1	C
MLIRTK280X110N	280-110	740	17.200	1	C
MLIRTK280X125N	280-125	755	17.700	1	C
MLIRTK280X140N	280-140	770	18.300	1	C
MLIRTK280X160N	280-160	790	19.200	1	C
MLIRTK280X180N	280-180	810	20.100	1	C
MLIRTK280X200N	280-200	830	21.000	1	C
MLIRTK280X225N	280-225	855	22.300	1	C
MLIRTHK315X75N	315-75	805	22.400	1	C
MLIRTHK315X90N	315-90	820	23.000	1	C
MLIRTK315X110N	315-110	840	23.900	1	C
MLIRTK315X125N	315-125	855	24.600	1	C
MLIRTK315X140N	315-140	870	25.300	1	C
MLIRTK315X160N	315-160	890	26.200	1	C
MLIRTK315X180N	315-180	910	27.200	1	C
MLIRTK315X200N	315-200	930	28.300	1	C
MLIRTK315X225N	315-225	955	29.700	1	C
MLIRTK315X250N	315-250	980	32.800	1	C
MLIRTHK355X90N	355-90	820	29.200	1	C
MLIRTK355X110N	355-110	840	30.200	1	C
MLIRTK355X125N	355-125	855	31.000	1	C
MLIRTK355X140N	355-140	870	31.900	1	C
MLIRTK355X160N	355-160	890	33.000	1	C
MLIRTK355X180N	355-180	910	34.200	1	C
MLIRTK355X200N	355-200	930	35.400	1	C
MLIRTK355X225N	355-225	955	37.000	1	C
MLIRTK355X250N	355-250	980	40.300	1	C
MLIRTK355X280N	355-280	1010	42.900	1	C
MLIRTK400X110N	400-110	840	37.800	1	C
MLIRTK400X125N	400-125	855	38.800	1	C
MLIRTK400X140N	400-140	870	39.800	1	C
MLIRTK400X160N	400-160	890	41.100	1	C
MLIRTK400X180N	400-180	910	42.500	1	C
MLIRTK400X200N	400-200	930	43.900	1	C
MLIRTK400X225N	400-225	955	45.700	1	C
MLIRTK400X250N	400-250	980	49.200	1	C
MLIRTK400X280N	400-280	1010	52.000	1	C
MLIRTK400X315N	400-315	1045	56.800	1	C
MLIRTK450X125N	450-125	855	48.600	1	C
MLIRTK450X140N	450-140	870	49.800	1	C
MLIRTK450X160N	450-160	890	51.400	1	C
MLIRTK450X180N	450-180	910	53.000	1	C
MLIRTK450X200N	450-200	930	54.600	1	C
MLIRTK450X225N	450-225	955	56.700	1	C
MLIRTK450X250N	450-250	980	60.500	1	C
MLIRTK450X280N	450-280	1010	63.600	1	C
MLIRTK450X315N	450-315	1045	68.800	1	C
MLIRTK450X355N	450-355	1085	74.000	1	C
MLIRTK500X140N	500-140	970	67.500	1	C
MLIRTK500X160N	500-160	990	69.400	1	C
MLIRTK500X180N	500-180	1010	71.300	1	C
MLIRTK500X200N	500-200	1030	73.200	1	C
MLIRTK500X225N	500-225	1055	75.700	1	C

Reducing Tee Eccentric Level Invert (Machined) - Continued

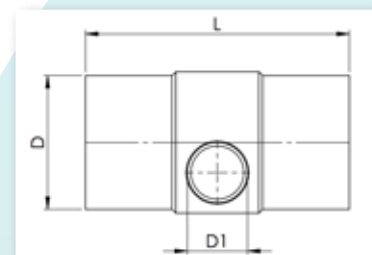

- PE100
- SDR 11 - Water PN16 / (Gas 10 Bar - Upon request)
- d500x250 - 710x560

Code	D-D1	L	Weight	Box Quantity	Delivery Code
	mm	mm	Kg		
PE100 SDR 11 Water PN 16 (Gas 10 Bar - Upon request)					
MLIRTK500X250N	500-250	1080	79.800	1	C
MLIRTK500X280N	500-280	1110	83.300	1	C
MLIRTK500X315N	500-315	1145	88.900	1	C
MLIRTK500X355N	500-355	1185	94.600	1	C
MLIRTK500X400N	500-400	1230	101.500	1	C
MLIRTK560X160N	560-160	1020	88.900	1	C
MLIRTK560X180N	560-180	1045	91.800	1	C
MLIRTK560X200N	560-200	1065	94.100	1	C
MLIRTK560X225N	560-225	1085	96.500	1	C
MLIRTK560X250N	560-250	1110	101.100	1	C
MLIRTK560X280N	560-280	1140	105.100	1	C
MLIRTK560X315N	560-315	1180	112.000	1	C
MLIRTK560X355N	560-355	1225	118.900	1	C
MLIRTK560X400N	560-400	1270	126.500	1	C
MLIRTK560X450N	560-450	1315	135.200	1	C
MLIRTK630X180N	630-180	1045	115.000	1	C
MLIRTK630X200N	630-200	1065	117.800	1	C
MLIRTK630X225N	630-225	1085	120.600	1	C
MLIRTK630X250N	630-250	1110	125.800	1	C
MLIRTK630X280N	630-280	1140	130.500	1	C
MLIRTK630X315N	630-315	1180	138.200	1	C
MLIRTK630X355N	630-355	1225	146.000	1	C
MLIRTK630X400N	630-400	1270	154.500	1	C
MLIRTK630X450N	630-450	1315	163.900	1	C
MLIRTK630X500N	630-500	1370	178.800	1	C
MLIRTK710X180N	710-180	1045	146.300	1	C
MLIRTK710X200N	710-200	1065	149.800	1	C
MLIRTK710X225N	710-225	1085	153.300	1	C
MLIRTK710X250N	710-250	1110	159.300	1	C
MLIRTK710X280N	710-280	1140	165.100	1	C
MLIRTK710X315N	710-315	1180	174.200	1	C
MLIRTK710X355N	710-355	1225	183.500	1	C
MLIRTK710X400N	710-400	1270	193.400	1	C
MLIRTK710X450N	710-450	1315	204.000	1	C
MLIRTK710X500N	710-500	1370	220.500	1	C
MLIRTK710X560N	710-560	1430	237.200	1	C

Reducing Tee Eccentric Level Invert (Machined) - Continued

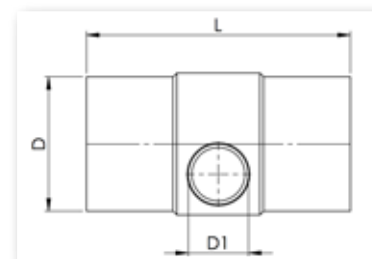

- PE100
- SDR 17 - Water PN10 (Gas 5 Bar - Upon request)
- d280x63 - 500x225

Code	D-D1	L	Weight	Box Quantity	Delivery Code
	mm	mm	Kg		
PE100 SDR 17 Water PN 10 (Gas 5 Bar - Upon request)					
MLIRTHK280X63V	280-63	690	10.900	1	C
MLIRTHK280X75V	280-75	705	11.300	1	C
MLIRTHK280X90V	280-90	720	11.700	1	C
MLIRTK280X110V	280-110	740	12.200	1	C
MLIRTK280X125V	280-125	755	12.700	1	C
MLIRTK280X140V	280-140	770	13.100	1	C
MLIRTK280X160V	280-160	790	13.800	1	C
MLIRTK280X180V	280-180	810	14.400	1	C
MLIRTK280X200V	280-200	830	15.200	1	C
MLIRTK280X225V	280-225	855	16.100	1	C
MLIRTHK315X75V	315-75	805	15.800	1	C
MLIRTHK315X90V	315-90	820	16.200	1	C
MLIRTK315X110V	315-110	840	16.900	1	C
MLIRTK315X125V	315-125	855	17.400	1	C
MLIRTK315X140V	315-140	870	17.900	1	C
MLIRTK315X160V	315-160	890	18.600	1	C
MLIRTK315X180V	315-180	910	19.400	1	C
MLIRTK315X200V	315-200	930	20.200	1	C
MLIRTK315X225V	315-225	955	21.200	1	C
MLIRTK315X250V	315-250	980	23.500	1	C
MLIRTHK355X90V	355-90	820	20.600	1	C
MLIRTK355X110V	355-110	840	21.400	1	C
MLIRTK355X125V	355-125	855	22.000	1	C
MLIRTK355X140V	355-140	870	22.600	1	C
MLIRTK355X160V	355-160	890	23.500	1	C
MLIRTK355X180V	355-180	910	24.400	1	C
MLIRTK355X200V	355-200	930	25.300	1	C
MLIRTK355X225V	355-225	955	26.500	1	C
MLIRTK355X250V	355-250	980	28.900	1	C
MLIRTK355X280V	355-280	1010	30.800	1	C
MLIRTK400X110V	400-110	840	26.600	1	C
MLIRTK400X125V	400-125	855	27.300	1	C
MLIRTK400X140V	400-140	870	28.000	1	C
MLIRTK400X160V	400-160	890	29.000	1	C
MLIRTK400X180V	400-180	910	30.000	1	C
MLIRTK400X200V	400-200	930	31.100	1	C
MLIRTK400X225V	400-225	955	32.400	1	C
MLIRTK400X250V	400-250	980	34.900	1	C
MLIRTK400X280V	400-280	1010	37.000	1	C
MLIRTK400X315V	400-315	1045	40.500	1	C
MLIRTK450X125V	450-125	855	34.100	1	C
MLIRTK450X140V	450-140	870	35.000	1	C
MLIRTK450X160V	450-160	890	36.200	1	C
MLIRTK450X180V	450-180	910	37.300	1	C
MLIRTK450X200V	450-200	930	38.500	1	C
MLIRTK450X225V	450-225	955	40.100	1	C
MLIRTK450X250V	450-250	980	42.700	1	C
MLIRTK450X280V	450-280	1010	45.100	1	C
MLIRTK450X315V	450-315	1045	48.800	1	C
MLIRTK450X355V	450-355	1085	52.700	1	C
MLIRTK500X140V	500-140	970	47.300	1	C
MLIRTK500X160V	500-160	990	48.700	1	C
MLIRTK500X180V	500-180	1010	50.100	1	C
MLIRTK500X200V	500-200	1030	51.500	1	C
MLIRTK500X225V	500-225	1055	53.400	1	C

Reducing Tee Eccentric Level Invert (Machined) - Continued

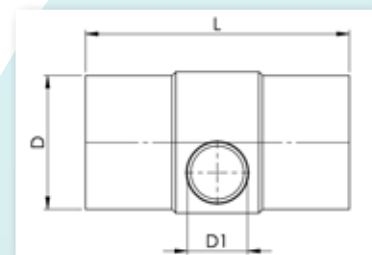

- PE100
- SDR 17 - Water PN10 (Gas 5 Bar - Upon request)
- d500x250 - 710x560

Code	D-D1	L	Weight	Box Quantity	Delivery Code
	mm	mm	Kg		
PE100 SDR 17 Water PN 10 (Gas 5 Bar - Upon request)					
MLIRTK500X250V	500-250	1080	56.200	1	C
MLIRTK500X280V	500-280	1110	58.900	1	C
MLIRTK500X315V	500-315	1145	62.900	1	C
MLIRTK500X355V	500-355	1185	67.200	1	C
MLIRTK500X400V	500-400	1230	72.300	1	C
MLIRTK560X160V	560-160	1020	62.300	1	C
MLIRTK560X180V	560-180	1045	64.500	1	C
MLIRTK560X200V	560-200	1065	66.200	1	C
MLIRTK560X225V	560-225	1085	67.900	1	C
MLIRTK560X250V	560-250	1110	71.100	1	C
MLIRTK560X280V	560-280	1140	74.100	1	C
MLIRTK560X315V	560-315	1180	79.100	1	C
MLIRTK560X355V	560-355	1225	84.200	1	C
MLIRTK560X400V	560-400	1270	89.900	1	C
MLIRTK560X450V	560-450	1315	96.400	1	C
MLIRTK630X180V	630-180	1045	80.500	1	C
MLIRTK630X200V	630-200	1065	82.500	1	C
MLIRTK630X225V	630-225	1085	84.600	1	C
MLIRTK630X250V	630-250	1110	88.200	1	C
MLIRTK630X280V	630-280	1140	91.700	1	C
MLIRTK630X315V	630-315	1180	97.200	1	C
MLIRTK630X355V	630-355	1225	103.000	1	C
MLIRTK630X400V	630-400	1270	109.100	1	C
MLIRTK630X450V	630-450	1315	116.100	1	C
MLIRTK630X500V	630-500	1370	127.100	1	C
MLIRTK710X180V	710-180	1045	102.400	1	C
MLIRTK710X200V	710-200	1065	105.000	1	C
MLIRTK710X225V	710-225	1085	107.500	1	C
MLIRTK710X250V	710-250	1110	111.800	1	C
MLIRTK710X280V	710-280	1140	116.000	1	C
MLIRTK710X315V	710-315	1180	122.700	1	C
MLIRTK710X355V	710-355	1225	129.500	1	C
MLIRTK710X400V	710-400	1270	136.700	1	C
MLIRTK710X450V	710-450	1315	144.400	1	C
MLIRTK710X500V	710-500	1370	156.500	1	C
MLIRTK710X560V	710-560	1430	169.000	1	C

45° Angle Branch Tee

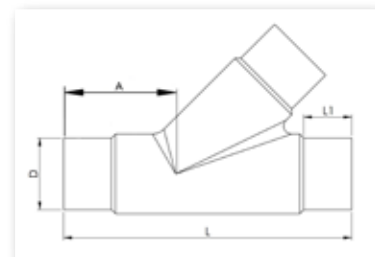

- PE100
- SDR 11 - Water PN16 / Gas 10 Bar
- SDR17 - Water PN10 / Gas 6 Bar
- d63 - 250 x 45

Code	D mm	L mm	L1 mm	A mm	Weight Kg	Box Quantity	Delivery Code
PE100 SDR 11 Water PN 16 Gas 10 Bar							
ABTHK63X45N	63	254	63	164	0.474	22	A
ABTHK75X45N	75	284	70	185	0.693	20	A
ABTHK90X45N	90	321	79	213	1.150	11	A
ABTHK110X45N	110	376	82	251	1.964	9	A
ABTHK125X45N	125	412	87	277	2.860	5	A
ABTHK140X45N	140	500	100	-	4.930	42	A
ABTHK160X45N	160	531	98	356	6.350	30	A
ABTHK180X45N	180	578	105	394	8.590	20	A
ABTHK200X45N	200	630	112	430	11.350	13	A
ABTHK225X45N	225	692	120	475	15.790	10	A
ABTHK250X45N	250	729	129	507	20.130	8	A
PE100 SDR 11 Water PN 16 Gas 10 Bar							
ABTHK63X45V	63	254	63	164	0.342	22	A
ABTHK75X45V	75	284	70	185	0.502	20	A
ABTHK90X45V	90	321	79	213	0.840	11	A
ABTHK110X45V	110	376	82	251	1.433	9	A
ABTHK125X45V	125	412	87	277	2.125	5	A
ABTHK140X45V	140	500	100	-	4.170	42	A
ABTHK160X45V	160	531	98	356	4.700	30	A
ABTHK180X45V	180	578	105	394	6.470	20	A
ABTHK200X45V	200	630	112	430	8.580	13	A
ABTHK225X45V	225	692	120	475	11.920	10	A
ABTHK250X45V	250	729	129	507	14.840	8	A

Y Piece

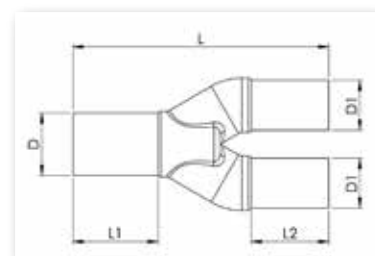

- PE100
- SDR 11 - Water PN16 / Gas 10 Bar
- d32x25 - 50x40

Code	D-D1 mm	L mm	L1 mm	L2 mm	Weight Kg	Box Quantity	Delivery Code
PE100 SDR 11 Water PN 16 Gas 10 Bar							
YPHK32X25N	32-25	156	44	41	0.070	120	C
YPHK40X32N	40-32	165	50	44	0.110	100	C
YPHK50X40N	50-40	186	55	50	0.180	50	C

Cross Piece

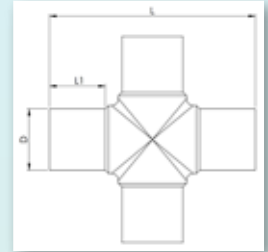

- PE100
- SDR 11 - Water PN16 / Gas 10 Bar
- SDR 17 - Water PN10 / Gas 6 Bar
- SDR 7.4 - Water PN25
- d63-355

Code	D	L	L1	Weight	Box Quantity	Delivery Code
	mm	mm	mm	Kg		
PE100 SDR 11 Water PN 16 Gas 10 Bar						
LSCRHK63X63N	63	229	68	-	1	C
LSCRHK75X75N	75	256	72	-	1	C
LSCRHK90X90N	90	303	82	-	1	C
LSCRHK110X110N	110	336	92	-	1	C
LSCRHK125X125N	125	350	89	-	1	C
LSCRHK140X140N	140	390	96	-	1	C
LSCRHK160X160N	160	423	104	-	1	C
LSCRHK180N	180	451	107	-	1	C
LSCRHK200N	200	501	117	-	1	C
LSCRHK225N	225	538	121	-	1	C
LSCRHK250N	250	596	131	-	1	C
LSCRHK280N	280	651	127	-	1	C
LSCRHK315N	315	703	152	-	1	C
LSCRHK355N	355	800	165	-	1	C
PE100 SDR 17 Water PN 10 Gas 6 Bar						
LSCRHK63X63V	63	229	68	-	1	C
LSCRHK75X75V	75	256	72	-	1	C
LSCRHK90X90V	90	303	82	-	1	C
LSCRHK110X110V	110	336	92	-	1	C
LSCRHK125X125V	125	350	89	-	1	C
LSCRHK140X140V	140	390	96	-	1	C
LSCRHK160X160V	160	423	104	-	1	C
LSCRHK180V	180	451	107	-	1	C
LSCRHK200V	200	501	117	-	1	C
LSCRHK225V	225	538	121	-	1	C
LSCRHK250V	250	596	131	-	1	C
LSCRHK280V	280	651	127	-	1	C
LSCRHK315V	315	703	152	-	1	C
LSCRHK355V	355	800	165	-	1	C
PE100 SDR 7.4 Water PN 25						
LSCRHK63X63T	63	229	68	-	1	C
LSCRHK75X75T	75	256	72	-	1	C
LSCRHK90X90T	90	303	82	-	1	C
LSCRHK110X110T	110	336	92	-	1	C
LSCRHK125X125T	125	350	89	-	1	C
LSCRHK140X140T	140	390	96	-	1	C
LSCRHK160X160T	160	423	104	-	1	C
LSCRHK180T	180	451	107	-	1	C
LSCRHK200T	200	501	117	-	1	C
LSCRHK225T	225	538	121	-	1	C
LSCRHK250T	250	596	131	-	1	C
LSCRHK280T	280	651	127	-	1	C
LSCRHK315T	315	703	152	-	1	C



Reduced Cross Piece



- PE100
- SDR 11 - Water PN16 / Gas 10 Bar
- d125-90

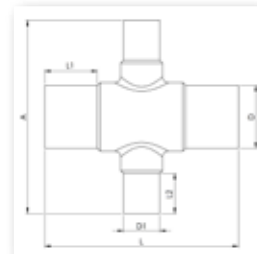

Code	D mm	L mm	L1 mm	L2 mm	L3 mm	Weight Kg	Box Quantity	Delivery Code
PE100 SDR 11 Water PN 16 Gas 10 Bar								
LSCRHK125X90N	125-90	351	92	83	343	2.140	60	C

Reducer

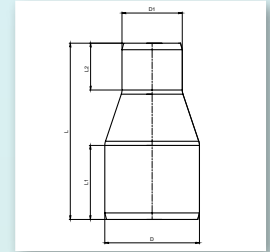

- PE100
- SDR 11- Water PN16 / Gas 10 Bar
- d25x20 - 200x180

Code	D-D1	L	L1	L2	Weight	Box Quantity	Delivery Code
	mm	mm	mm	mm	Kg		
PE100 SDR 11 Water PN 16 Gas 10 Bar							
SPRHK25X20N	25-20	120	41	41	0.024	80	A
SPRHK32X20N	32-20	115	44	41	0.030	50	A
SPRHK32X25N	32-25	130	44	41	0.034	50	A
SPRHK40X20N	40-20	94	45	36	0.030	10	A
SPRHK40X25N	40-25	130	49	41	0.042	50	A
SPRHK40X32N	40-32	130	49	44	0.052	50	A
SPRHK50X25N	50-25	140	55	41	0.068	40	A
SPRHK50X32N	50-32	140	55	44	0.074	40	A
SPRHK50X40N	50-40	140	55	49	0.078	40	A
SPRHK63X25N	63-25	143	63	41	0.106	20	A
SPRHK63X32N	63-32	150	63	44	0.112	20	A
SPRHK63X40N	63-40	150	63	49	0.116	20	A
SPRHK63X50N	63-50	150	63	55	0.140	20	A
SPRHK75X32N	75-32	170	70	44	0.164	36	A
SPRHK75X40N	75-40	170	70	49	0.166	36	A
SPRHK75X50N	75-50	175	70	55	0.194	36	A
SPRHK75X63N	75-63	175	70	63	0.232	36	A
SPRHK90X50N	90-50	190	79	55	0.288	36	A
SPRHK90X63N	90-63	196	79	63	0.302	36	A
SPRHK90X75N	90-75	200	79	70	0.390	36	A
SPRHK110X50N	110-50	176	88	57	0.460	45	A
SPRHK110X63N	110-63	214	82	63	0.496	30	A
SPRHK110X75N	110-75	216	82	70	0.546	30	A
SPRHK110X90N	110-90	213	82	79	0.586	30	A
SPRHK125X63N	125-63	195	87	63	0.602	24	A
SPRHK125X75N	125-75	215	87	70	0.642	24	A
SPRHK125X90N	125-90	222	87	79	0.729	24	A
SPRHK125X110N	125-110	222	87	82	0.844	18	A
SPRHK140X75N	140-75	225	92	70	0.826	16	A
SPRHK140X90N	140-90	225	92	79	0.824	16	A
SPRHK140X110N	140-110	233	92	82	1.002	16	A
SPRHK140X125N	140-125	225	92	87	1.090	16	A
SPRHK160X90N	160-90	245	98	79	1.220	16	A
SPRHK160X110N	160-110	250	98	82	1.280	16	A
SPRHK160X125N	160-125	250	98	87	1.442	16	A
SPRHK160X140N	160-140	245	98	92	1.468	16	A
SPRHK180X63N	180-63	226	107	68	1.310	6	A
SPRHK180X90N	180-90	245	106	79	1.495	8	A
SPRHK180X110N	180-110	255	105	82	1.588	6	A
SPRHK180X125N	180-125	255	105	87	1.646	6	A
SPRHK180X140N	180-140	250	105	92	1.800	6	A
SPRHK180X160N	180-160	255	105	98	2.068	6	A
SPRHK200X90N	200-90	253	116	83	1.870	6	A
SPRHK200X110N	200-110	275	112	82	2.192	8	A
SPRHK200X140N	200-140	275	112	92	2.342	8	A
SPRHK200X160N	200-160	270	112	98	2.364	8	A
SPRHK200X180N	200-180	275	112	105	2.654	8	A

Reducer - Continued

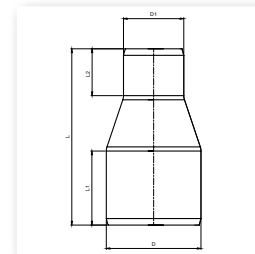

- PE100
- SDR 11 - Water PN16 / Gas 10 Bar up to 400mm
- SDR 11 - Water PN16 / Gas 10 Bar sizes above 400mm upon request
- d225x110 - 630x560

Code	D-D1	L	L1	L2	Weight	Box Quantity	Delivery Code
	mm	mm	mm	mm	Kg		
PE100 SDR 11 Water PN 16 Gas 10 Bar							
SPRHK225X110N	225-110	295	120	82	2.848	6	A
SPRHK225X160N	225-160	280	120	98	3.024	5	A
SPRHK225X180N	225-180	280	120	105	3.336	5	A
SPRHK225X200N	225-200	300	120	112	3.758	5	A
SPRHK250X160N	250-160	294	129	98	3.542	2	A
SPRHK250X180N	250-180	305	129	105	4.208	2	A
SPRHK250X200N	250-200	310	129	112	4.346	2	A
SPRHK250X225N	250-225	305	129	120	4.708	2	A
SPRHK280X180N	280-180	348	139	105	5.390	2	A
SPRHK280X200N	280-200	348	139	112	5.758	2	A
SPRHK280X225N	280-225	336	139	120	6.050	2	A
SPRHK280X250N	280-250	348	139	129	6.818	2	A
SPRHK315X200N	315-200	330	160	120	6.500	1	A
SPRHK315X225N	315-225	375	150	120	7.652	2	A
SPRHK315X250N	315-250	375	150	129	8.066	2	A
SPRHK315X280N	315-280	355	150	139	8.678	2	A
SPRHK355X225N	355-225	337	164	130	8.400	1	A
SPRHK355X250N	355-250	426	175	145	10.900	1	A
SPRHK355X280N	355-280	426	170	155	11.700	1	A
SPRHK355X315N	355-315	426	175	170	12.700	1	A
SPRHK400X225N	400-225	365	179	130	11.500	1	A
SPRHK400X250N	400-250	358	179	130	11.700	1	A
SPRHK400X280N	400-280	465	190	155	14.800	1	A
SPRHK400X315N	400-315	430	179	150	14.560	1	A
SPRHK400X355N	400-355	463	190	185	17.000	1	A
SPRHK450X280N	450-280	401	195	150	16.300	1	A
SPRHK450X315N	450-315	401	195	160	16.900	1	A
SPRHK450X355N	450-355	392	195	164	17.400	1	A
SPRHK450X400N	450-400	394	195	179	18.600	1	A
SPRHK500X315N	500-315	432	212	160	21.900	1	A
SPRHK500X355N	500-355	425	212	164	22.400	1	A
SPRHK500X400N	500-400	426	212	179	23.500	1	A
SPRHK500X450N	500-450	427	212	195	25.100	1	A
SPRHK560X355N	560-355	465	235	164	30.100	1	A
SPRHK560X400N	560-400	467	235	179	31.100	1	A
SPRHK560X450N	560-450	469	235	195	32.600	1	A
SPRHK560X500N	560-500	471	235	212	34.500	1	A
SPRHK630X400N	630-400	507	256	179	41.700	1	A
SPRHK630X450N	630-450	509	256	195	43.000	1	A
SPRHK630X500N	630-500	511	256	212	44.700	1	A
SPRHK630X560N	630-560	517	256	235	47.700	1	A

Reducer - Continued

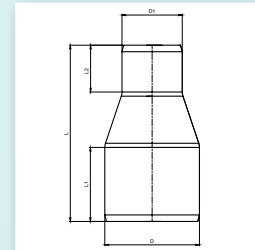

- PE100
- SDR17 - Water PN10 / Gas 6 Bar
- d50x32 - 315x280

Code	D-D1	L	L1	L2	Weight	Box Quantity	Delivery Code
	mm	mm	mm	mm	Kg		
PE100 SDR 17 Water PN 10 Gas 6 Bar							
SPRHK50X32V	50-32				Available upon request		
SPRHK50X40V	50-40				Available upon request		
SPRHK63X32V	63-32	142	63	46	0.080	15	A
SPRHK63X40V	63-40				Available upon request		
SPRHK63X50V	63-50	152	64	58	0.095	15	A
SPRHK75X40V	75-40	143	72	49	0.120	48	A
SPRHK75X50V	75-50	145	73	57	0.130	48	A
SPRHK75X63V	75-63	175	70	63	0.199	36	A
SPRHK90X50V	90-50	138	82	55	0.190	60	A
SPRHK90X63V	90-63	196	79	63	0.258	36	A
SPRHK90X75V	90-75	200	79	70	0.330	36	A
SPRHK110X50V	110-50	176	88	57	0.300	45	A
SPRHK110X63V	110-63	214	82	63	0.421	30	A
SPRHK110X75V	110-75	216	82	70	0.463	30	A
SPRHK110X90V	110-90	213	82	79	0.498	30	A
SPRHK125X63V	125-63	195	87	63	0.511	24	A
SPRHK125X75V	125-75	215	87	70	0.545	24	A
SPRHK125X90V	125-90	222	87	79	0.619	24	A
SPRHK125X110V	125-110	222	87	82	0.717	18	A
SPRHK140X75V	140-75	225	92	70	0.702	16	A
SPRHK140X90V	140-90	225	92	79	0.700	16	A
SPRHK140X110V	140-110	233	92	82	0.851	16	A
SPRHK140X125V	140-125	225	92	87	0.926	16	A
SPRHK160X90V	160-90	245	98	79	1.038	16	A
SPRHK160X110V	160-110	250	98	82	1.088	16	A
SPRHK160X125V	160-125	250	98	87	1.225	16	A
SPRHK160X140V	160-140	245	98	92	1.247	16	A
SPRHK180X63V	180-63	226	107	68	0.960	1	A
SPRHK180X90V	180-90	244	105	80	1.040	10	A
SPRHK180X110V	180-110	255	105	82	1.350	6	A
SPRHK180X125V	180-125	255	105	87	1.414	6	A
SPRHK180X140V	180-140	250	105	92	1.530	6	A
SPRHK180X160V	180-160	255	105	98	1.757	6	A
SPRHK200X90V	200-90	253	116	83	1.300	6	A
SPRHK200X110V	200-110	275	112	82	1.863	8	A
SPRHK200X140V	200-140	275	112	92	1.990	8	A
SPRHK200X160V	200-160	270	112	98	2.009	8	A
SPRHK200X180V	200-180	275	112	105	2.255	8	A
SPRHK225X110V	225-110	295	120	82	2.420	6	A
SPRHK225X160V	225-160	280	120	98	2.570	5	A
SPRHK225X140V	225-140	290	133	114	1.980	4	A
SPRHK225X180V	225-180	280	120	105	2.835	5	A
SPRHK225X200V	225-200	300	120	112	3.194	5	A
SPRHK250X160V	250-160	294	129	98	3.017	2	A
SPRHK250X180V	250-180	305	129	105	3.576	2	A
SPRHK250X200V	250-200	310	129	112	3.694	2	A
SPRHK250X225V	250-225	305	129	120	3.995	2	A
SPRHK280X180V	280-180	348	139	105	4.589	2	A
SPRHK280X200V	280-200	348	139	112	4.894	2	A
SPRHK280X225V	280-225	336	139	120	5.142	2	A
SPRHK280X250V	280-250	348	139	129	5.795	2	A
SPRHK315X200V	315-200	330	160	120	4.500	1	A
SPRHK315X225V	315-225	375	150	120	6.504	2	A
SPRHK315X250V	315-250	375	150	129	6.856	2	A
SPRHK315X280V	315-280	355	150	139	7.383	2	A



Reducer - Continued



- PE100
- SDR 17 - Water PN10 / Gas 6 Bar up to 400mm
- SDR 17 - Water PN10 / Gas 6 Bar sizes above 400mm upon request
- d355x250 - 1000x900

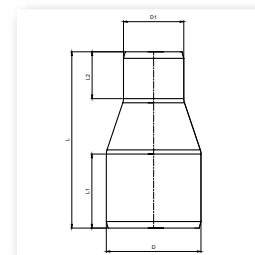

Code	D-D1	L	L1	L2	Weight	Box Quantity	Delivery Code
	mm	mm	mm	mm	Kg		
PE100 SDR 17 Water PN 10 Gas 6 Bar							
SPRHK355X250V	355-250	426	175	145	9.600	1	A
SPRHK355X280V	355-280	426	170	155	10.200	1	A
SPRHK355X315V	355-315	426	175	170	11.100	1	A
SPRHK400X225V	400-225	365	179	130	7.900	1	A
SPRHK400X250V	400-250	358	179	130	8.000	1	A
SPRHK400X280V	400-280	465	190	155	13.200	1	A
SPRHK400X315V	400-315	430	179	150	12.376	1	A
SPRHK400X355V	400-355	463	190	185	15.000	1	A
SPRHK450X280V	450-280	401	195	150	11.200	1	A
SPRHK450X315V	450-315	401	195	160	11.500	1	A
SPRHK450X355V	450-355	392	195	164	11.900	1	A
SPRHK450X400V	450-400	394	195	179	12.600	1	A
SPRHK500X315V	500-315	432	212	160	15.000	1	A
SPRHK500X355V	500-355	425	212	164	15.300	1	A
SPRHK500X400V	500-400	426	212	179	16.000	1	A
SPRHK500X450V	500-450	427	212	195	17.000	1	A
SPRHK560X355V	560-355	465	235	164	20.700	1	A
SPRHK560X400V	560-400	467	235	179	21.300	1	A
SPRHK560X450V	560-450	469	235	195	22.200	1	A
SPRHK560X500V	560-500	471	235	212	23.400	1	A
SPRHK630X400V	630-400	507	256	179	28.500	1	A
SPRHK630X450V	630-450	509	256	195	29.400	1	A
SPRHK630X500V	630-500	511	256	212	30.500	1	A
SPRHK630X560V	630-560	517	256	235	32.500	1	A
SPRHK710X500V	710-500	890	350	350	61.800	1	A
SPRHK710X560V	710-560	870	350	350	64.100	1	A
SPRHK710X630V	710-630	840	350	350	66.300	1	A
SPRHK800X560V	800-560	900	350	350	79.600	1	A
SPRHK800X630V	800-630	880	350	350	82.500	1	A
SPRHK800X710V	800-710	850	350	350	85.400	1	A
SPRHK900X800V	900-800	910	400	350	116.700	1	A
SPRHK900X710V	900-710	940	400	350	113.100	1	A
SPRHK900X630V	900-630	970	400	350	110.800	1	A
SPRHK1000X710V	1000-710	970	400	350	138.400	1	A
SPRHK1000X800V	1000-800	940	400	350	141.200	1	A
SPRHK1000X900V	1000-900	900	400	350	143.700	1	A

Reducer - Continued

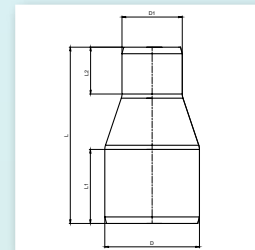

- PE100
- SDR 7.4 - Water PN25
- d40x25 - 225x200

Code	D-D1	L	L1	L2	Weight	Box Quantity	Delivery Code
	mm	mm	mm	mm	Kg		
PE100 SDR 7.4 Water PN 25							
SPRHK40X25T	40-25	-	-	-	-	70	C
SPRHK40X32T	40-32	-	-	-	-	60	C
SPRHK50X25T	50-25	114	56	44	0.080	130	C
SPRHK50X32T	50-32	115	56	48	0.080	80	C
SPRHK50X40T	50-40	110	54	50	0.090	80	C
SPRHK63X25T	63-25	127	64	44	0.130	72	C
SPRHK63X32T	63-32	127	66	49	0.140	72	C
SPRHK63X40T	63-40	128	65	52	0.140	72	C
SPRHK63X50T	63-50	136	66	57	0.170	50	C
SPRHK75X32T	75-32	142	73	46	0.210	44	C
SPRHK75X40T	75-40	143	72	49	0.220	48	C
SPRHK75X50T	75-50	145	73	57	0.230	48	C
SPRHK75X63T	75-63	141	73	65	0.270	30	C
SPRHK90X50T	90-50	138	82	55	0.360	60	C
SPRHK90X63T	90-63	163	82	66	0.390	60	C
SPRHK90X75T	90-75	167	83	73	0.440	36	C
SPRHK110X50T	110-50	176	88	57	0.570	45	C
SPRHK110X63T	110-63	178	89	67	0.750	36	C
SPRHK110X75T	110-75	178	88	73	0.650	36	C
SPRHK110X90T	110-90	186	88	82	0.710	30	C
SPRHK125X63T	125-63	181	90	66	0.790	26	C
SPRHK125X75T	125-75	187	91	73	0.820	24	C
SPRHK125X90T	125-90	189	91	81	0.900	18	C
SPRHK125X110T	125-110	191	90	90	1.000	24	C
SPRHK140X90T	140-90	204	95	81	1.150	24	C
SPRHK140X110T	140-110	203	95	91	1.270	19	C
SPRHK140X125T	140-125	198	96	93	1.440	18	C
SPRHK160X90T	160-90	226	106	83	1.720	14	C
SPRHK160X110T	160-110	226	106	92	1.840	14	C
SPRHK160X125T	160-125	216	105	93	1.740	12	C
SPRHK160X140T	160-140	204	100	93	1.850	8	C
SPRHK180X125T	180-125	240	110	90	2.270	6	C
SPRHK180X140T	180-140	218	106	94	2.260	12	C
SPRHK180X160T	180-160	220	105	105	2.460	6	C
SPRHK200X140T	200-140	234	111	95	2.790	6	C
SPRHK200X160T	200-160	241	117	100	3.000	6	C
SPRHK200X180T	200-180	234	114	106	3.710	4	C
SPRHK225X160T	225-160	258	115	104	3.950	126 - Pallet	C
SPRHK225X180T	225-180	271	122	118	4.220	4	C
SPRHK225X200T	225-200	257	118	116	4.350	72 - Pallet	C

Reducer - Continued

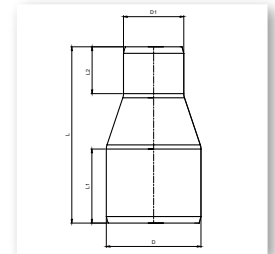

- PE100
- SDR 9 - Water PN20
- d63x40 - 225x200

Code	D-D1	L	L1	L2	Weight	Box Quantity	Delivery Code
	mm	mm	mm	mm	Kg		
PE100 SDR 9 Water PN 20							
SPRHK63X40R	63-40	128	65	52	0.120	72	C
SPRHK63X50R	63-50	136	66	57	0.140	50	C
SPRHK75X40R	75-40	143	72	49	0.180	48	C
SPRHK75X50R	75-50	145	73	57	0.200	48	C
SPRHK75X63R	75-63	141	73	65	0.240	30	C
SPRHK90X50R	90-50	138	82	55	0.300	60	C
SPRHK90X63R	90-63	163	82	66	0.320	60	C
SPRHK90X75R	90-75	167	83	73	0.400	36	C
SPRHK110X50R	110-50	176	88	57	0.460	45	C
SPRHK110X63R	110-63	178	89	67	0.490	36	C
SPRHK110X75R	110-75	178	88	73	0.530	36	C
SPRHK110X90R	110-90	186	88	82	0.580	30	C
SPRHK125X63R	125-63	181	90	66	0.650	26	C
SPRHK125X75R	125-75	187	91	73	0.680	24	C
SPRHK125X90R	125-90	189	91	81	0.720	18	C
SPRHK125X110R	125-110	191	90	90	0.800	24	C
SPRHK140X90R	140-90	204	95	81	0.920	24	C
SPRHK140X110R	140-110	203	95	91	1.000	19	C
SPRHK140X125R	140-125	198	96	93	1.070	18	C
SPRHK160X90R	160-90	226	106	83	1.270	14	C
SPRHK160X110R	160-110	226	106	92	1.360	14	C
SPRHK160X125R	160-125	216	105	93	1.390	12	C
SPRHK160X140R	160-140	204	100	93	1.480	8	C
SPRHK180X125R	180-125	240	110	90	1.750	6	C
SPRHK180X140R	180-140	218	106	94	1.780	12	C
SPRHK180X160R	180-160	220	105	105	1.930	6	C
SPRHK200X140R	200-140	234	111	95	2.240	6	C
SPRHK200X160R	200-160	241	117	100	2.470	6	C
SPRHK200X180R	200-180	234	114	106	2.530	4	C
SPRHK225X160R	225-160	258	115	104	3.130	126 - Pallet	C
SPRHK225X180R	225-180	271	122	118	3.500	4	C
SPRHK225X200R	225-200	257	118	116	3.560	72 - Pallet	C

Reducer - Short Spigot

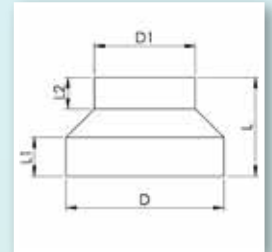

- PE100
- SDR11 - Water PN16 / (Gas 10 Bar - Upon request)
- d25x20 - 280x250

Code	D-D1	L	L1	L2	Weight	Box Quantity	Delivery Code
	mm	mm	mm	mm	Kg		
PE100 SDR 11 Water PN 16 (Gas 10 Bar - Upon request)							
SSRHK25X20N	25-20	68	20	20	0.004	1	C
SSRHK32X20N	32-20	68	23	23	0.014	80	C
SSRHK32X25N	32-25	38	16	14	0.010	10	C
SSRHK40X20N	40-20	50	18	13	0.014	1	C
SSRHK40X25N	40-25	47	19	14	0.016	10	C
SSRHK40X32N	40-32	39	19	15	0.016	10	C
SSRHK50X25N	50-25	53	19	17	0.027	10	C
SSRHK50X32N	50-32	44	18	14	0.029	10	C
SSRHK50X40N	50-40	46	20	19	0.029	10	C
SSRHK63X32N	63-32	63	23	22	0.052	5	C
SSRHK63X40N	63-40	58	24	18	0.052	5	C
SSRHK63X50N	63-50	54	25	20	0.059	5	C
SSRHK75X32N	75-32	70	25	10	0.072	1	C
SSRHK75X40N	75-40	70	29	22	0.074	2	C
SSRHK75X50N	75-50	71	28	23	0.081	2	C
SSRHK75X63N	75-63	70	29	31	0.100	2	C
SSRHK90X50N	90-50	73	26	22	0.120	2	C
SSRHK90X63N	90-63	71	29	24	0.130	2	C
SSRHK90X75N	90-75	80	33	33	0.160	2	C
SSRHK110X50N	110-50	90	33	29	0.210	2	C
SSRHK110X63N	110-63	105	40	36	0.245	4	C
SSRHK110X75N	110-75	90	34	35	0.250	2	C
SSRHK110X90N	110-90	104	40	41	0.285	4	C
SSRHK125X63N	125-63	100	40	34	0.300	2	C
SSRHK125X75N	125-75	98	32	19	0.310	18	C
SSRHK125X90N	125-90	110	42	41	0.370	18	C
SSRHK125X110N	125-110	100	40	48	0.400	2	C
SSRHK140X75N	140-75	110	49	37	0.460	2	C
SSRHK140X90N	140-90	126	45	28	0.440	2	C
SSRHK140X110N	140-110	126	45	34	0.500	2	C
SSRHK140X125N	140-125	128	45	42	0.550	2	C
SSRHK160X90N	160-90	120	53	37	0.670	2	C
SSRHK160X110N	160-110	125	50	39	0.740	2	C
SSRHK160X125N	160-125	120	54	45	0.700	2	C
SSRHK160X140N	160-140	98	44	43	0.810	2	C
SSRHK180X90N	180-90	130	59	37	0.990	1	C
SSRHK180X110N	180-110	130	60	40	0.990	1	C
SSRHK180X125N	180-125	152	62	42	1.050	1	C
SSRHK180X140N	180-140	135	51	47	1.150	8	C
SSRHK180X160N	180-160	131	60	55	1.210	1	C
SSRHK200X140N	200-140	140	60	48	1.260	1	C
SSRHK200X160N	200-160	140	60	54	1.520	1	C
SSRHK200X180N	200-180	140	60	61	1.420	1	C
SSRHK225X140N	225-140	160	65	57	1.800	1	C
SSRHK225X160N	225-160	190	65	50	2.030	1	C
SSRHK225X180N	225-180	190	65	55	2.050	1	C
SSRHK225X200N	225-200	160	71	71	1.900	1	C
SSRHK250X160N	250-160	157	55	55	2.120	6	C
SSRHK250X180N	250-180	150	62	50	2.360	6	C
SSRHK250X200N	250-200	138	60	50	2.280	6	C
SSRHK250X225N	250-225	142	50	68	2.170	6	C
SSRHK280X180N	280-180	200	85	70	3.200	1	C
SSRHK280X200N	280-200	160	72	51	2.830	114	C
SSRHK280X225N	280-225	154	72	57	2.790	110	C
SSRHK280X250N	280-250	150	71	64	2.870	84	C

Reducer - Short Spigot - Continued

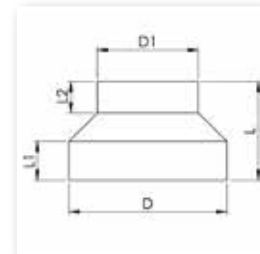

- PE100
- SDR11 - Water PN16 / (Gas 10 Bar - Upon request)
- d315x200 - 1000x900

Code	D-D1	L	L1	L2	Weight	Box Quantity	Delivery Code
	mm	mm	mm	mm	Kg		
PE100 SDR 11 Water PN 16 (Gas 10 Bar - Upon request)							
SSRHK315X200N	315-200	231	95	85	4.600	1	C
SSRHK315X225N	315-225	184	82	57	4.020	72	C
SSRHK315X250N	315-250	178	81	62	4.060	72	C
SSRHK315X280N	315-280	175	79	72	4.150	54	C
SSRHK355X225N	355-225	213	92	57	5.240	48	C
SSRHK355X250N	355-250	195	87	62	5.270	48	C
SSRHK355X280N	355-280	200	87	77	5.820	48	C
SSRHK355X315N	355-315	188	88	78	5.730	35	C
SSRHK400X225N	400-225	160	64	40	5.700	1	C
SSRHK400X250N	400-250	150	61	40	5.400	1	C
SSRHK400X280N	400-280	226	96	73	7.790	42	C
SSRHK400X315N	400-315	218	97	83	7.940	42	C
SSRHK400X355N	400-355	208	97	92	8.020	30	C
SSRHK450X280N	450-280	160	65	40	7.500	1	C
SSRHK450X315N	450-315	206	64	76	7.800	20	C
SSRHK450X355N	450-355	203	64	92	9.040	20	C
SSRHK450X400N	450-400	188	64	99	9.130	20	C
SSRHK500X315N	500-315	170	71	40	10.000	1	C
SSRHK500X355N	500-355	210	62	81	11.700	15	C
SSRHK500X400N	500-400	210	63	96	11.540	15	C
SSRHK500X450N	500-450	166	63	63	15.070	18	C
SSRHK560X355N	560-355	170	65	40	12.600	1	C
SSRHK560X400N	560-400	240	60	98	15.080	16	C
SSRHK560X450N	560-450	187	60	65	13.240	18	C
SSRHK560X500N	560-500	192	62	61	12.340	16	C
SSRHK630X400N	630-400	190	78	40	18.200	1	C
SSRHK630X450N	630-450	234	60	68	19.570	10	C
SSRHK630X500N	630-500	192	62	61	18.120	10	C
SSRHK630X560N	630-560	188	64	65	17.340	12	C
SSRHK710X560N	710-560	160	66	40	21.640	10	C
SSRHK710X630N	710-630	160	66	62	21.400	10	C
SSRHK800X710N	800-710	160	62	62	26.140	7	C
SSRHK900X800N	900-800	160	62	62	31.500	1	C
SSRHK1000X900N	1000-900	170	65	56	42.350	1	C

Reducer - Short Spigot - Continued

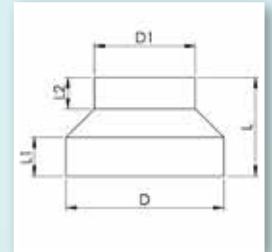

- PE100
- SDR17 - Water PN10 / (Gas 6 Bar - Upon request)
- d63x32 - 450x280

Code	D-D1	L	L1	L2	Weight	Box Quantity	Delivery Code
	mm	mm	mm	mm	Kg		
PE100 SDR 17 Water PN 10 (Gas 6 Bar - Upon request)							
SSRHK63X32V	63-32	63	23	22	0.033	5	C
SSRHK63X50V	63-50	54	25	20	0.040	5	C
SSRHK75X50V	75-50	71	28	23	0.055	2	C
SSRHK75X63V	75-63	70	29	31	0.062	2	C
SSRHK90X50V	90-50	73	26	22	0.100	2	C
SSRHK90X63V	90-63	71	29	24	0.120	2	C
SSRHK90X75V	90-75	80	33	33	0.100	2	C
SSRHK110X50V	110-50	90	33	29	0.210	2	C
SSRHK110X63V	110-63	91	42	23	0.200	2	C
SSRHK110X75V	110-75	90	34	35	0.160	2	C
SSRHK110X90V	110-90	88	40	28	0.180	2	C
SSRHK125X63V	125-63	100	40	34	0.200	2	C
SSRHK125X75V	125-75	103	48	31	0.270	2	C
SSRHK125X90V	125-90	100	38	30	0.270	2	C
SSRHK125X110V	125-110	100	40	40	0.275	18	C
SSRHK140X75V	140-75	110	49	37	0.290	2	C
SSRHK140X90V	140-90	126	45	28	0.300	2	C
SSRHK140X110V	140-110	126	45	34	0.330	2	C
SSRHK140X125V	140-125	128	45	42	0.380	2	C
SSRHK160X90V	160-90	120	53	37	0.500	2	C
SSRHK160X110V	160-110	125	50	39	0.530	2	C
SSRHK160X125V	160-125	120	54	45	0.480	2	C
SSRHK160X140V	160-140	98	44	43	0.610	2	C
SSRHK180X90V	180-90	130	59	37	0.690	1	C
SSRHK180X110V	180-110	130	60	40	0.770	1	C
SSRHK180X125V	180-125	143	52	40	0.705	12	C
SSRHK180X140V	180-140	135	51	47	0.670	12	C
SSRHK180X160V	180-160	140	60	50	0.750	4	C
SSRHK200X140V	200-140	140	60	48	0.860	1	C
SSRHK200X160V	200-160	140	60	54	1.010	1	C
SSRHK200X180V	200-180	145	62	54	0.955	1	C
SSRHK225X140V	225-140	160	65	57	1.800	1	C
SSRHK225X160V	225-160	190	65	50	1.400	1	C
SSRHK225X180V	225-180	190	65	55	1.260	1	C
SSRHK225X200V	225-200	149	62	52	1.210	1	C
SSRHK250X160V	250-160	157	55	55	1.450	6	C
SSRHK250X180V	250-180	150	62	50	1.950	40	C
SSRHK250X200V	250-200	138	60	50	1.680	40	C
SSRHK250X225V	250-225	142	50	68	1.660	40	C
SSRHK280X180V	280-180	200	85	70	2.200	1	C
SSRHK280X200V	280-200	160	72	51	1.940	125	C
SSRHK280X225V	280-225	154	72	57	1.950	110	C
SSRHK280X250V	280-250	150	71	64	2.000	80	C
SSRHK315X200V	315-200	231	95	85	3.100	1	C
SSRHK315X225V	315-225	184	82	57	2.850	80	C
SSRHK315X250V	315-250	178	81	62	4.060	72	C
SSRHK315X280V	315-280	175	79	72	2.840	54	C
SSRHK355X225V	355-225	213	92	57	3.730	54	C
SSRHK355X250V	355-250	195	87	62	3.850	54	C
SSRHK355X280V	355-280	200	87	77	3.960	48	C
SSRHK355X315V	355-315	188	88	78	3.990	35	C
SSRHK400X225V	400-225	160	64	40	3.900	1	C
SSRHK400X250V	400-250	150	61	40	3.800	1	C
SSRHK400X280V	400-280	226	96	73	5.360	42	C
SSRHK400X315V	400-315	218	97	83	5.570	48	C
SSRHK400X355V	400-355	208	97	92	5.520	30	C
SSRHK450X280V	450-280	160	65	40	5.200	1	C

Reducer - Short Spigot - Continued

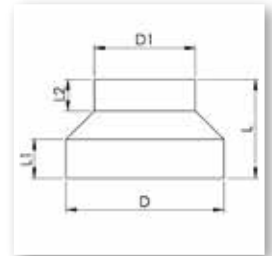

- PE100
- SDR17 - Water PN10 / Gas 6 Bar (Upon request)
- SDR 7.4 - Water PN25
- d250x160 - 1200x1000

Code	D-D1	L	L1	L2	Weight	Box Quantity	Delivery Code
	mm						
PE100 SDR 17 Water PN 10 (Gas 6 Bar - Upon request)							
SSRHK450X315V	450-315	206	64	76	6.400	20	C
SSRHK450X355V	450-355	203	64	92	6.050	20	C
SSRHK450X400V	450-400	188	64	99	6.100	20	C
SSRHK500X315V	500-315	170	71	40	6.900		C
SSRHK500X355V	500-355	210	62	81	7.970	15	C
SSRHK500X400V	500-400	210	63	96	7.120	15	C
SSRHK500X450V	500-450	166	63	63	7.130	18	C
SSRHK560X355V	560-355	170	65	40	8.800	1	C
SSRHK560X400V	560-400	240	60	98	10.970	16	C
SSRHK560X450V	560-450	187	60	65	9.040	18	C
SSRHK560X500V	560-500	192	62	61	9.040	18	C
SSRHK630X400V	630-400	190	78	40	12.700	1	C
SSRHK630X450V	630-450	234	60	68	13.800	10	C
SSRHK630X500V	630-500	192	62	61	13.300	10	C
SSRHK630X560V	630-560	188	64	65	14.260	12	C
SSRHK710X500V	710-500	190	84	40	16.600	1	C
SSRHK710X560V	710-560	160	66	40	14.370	10	C
SSRHK710X630V	710-630	160	66	62	18.450	10	C
SSRHK800X560V	800-560	200	85	40	22.500	1	C
SSRHK800X630V	800-630	180	85	40	20.400	1	C
SSRHK800X710V	800-710	150	78	40	16.800	1	C
SSRHK900X630V	900-630	220	96	40	31.600	1	C
SSRHK900X710V	900-710	190	89	40	27.500	1	C
SSRHK900X800V	900-800	160	85	40	22.900	1	C
SSRHK1000X710V	1000-710	220	91	40	39.700	1	C
SSRHK1000X800V	1000-800	190	86	40	34.400	1	C
SSRHK1000X900V	1000-900	150	75	40	26.700	1	C
SSRK1200X1000V	1200-1000	190	922	40	51.900	1	C
PE100 SDR 7.4 Water PN 25							
SSRHK250X160T	250-160	157	55	55	2.800	1	C
SSRHK250X180T	250-180	150	62	50	2.620	1	C
SSRHK250X200T	250-200	138	60	50	2.750	1	C
SSRHK250X225T	250-225	142	50	68	2.540	1	C
SSRHK280X200T	280-200	160	72	51	3.070	1	C
SSRHK280X225T	280-225	154	72	57	3.520	1	C
SSRHK280X250T	280-250	150	71	64	3.820	1	C
SSRHK315X225T	315-225	184	82	57	5.430	1	C
SSRHK315X250T	315-250	178	81	62	5.550	1	C
SSRHK315X280T	315-280	175	79	72	5.900	1	C
SSRHK355X250T	355-250	195	87	62	7.040	1	C
SSRHK355X280T	355-280	200	87	77	7.600	1	C
SSRHK355X315T	355-315	188	88	78	7.600	1	C
SSRHK400X280T	400-280	226	96	73	10.190	1	C
SSRHK400X315T	400-315	218	97	83	10.960	1	C
SSRHK400X355T	400-355	208	97	92	11.170	1	C
SSRHK450X315T	450-315	206	64	76	11.190	1	C
SSRHK450X355T	450-355	203	64	92	11.750	1	C
SSRHK450X400T	450-400	188	64	99	12.300	1	C
SSRHK500X450T	500-450	166	63	63	13.560	1	C
SSRHK560X400T	560-400	240	60	98	19.000	1	C
SSRHK630X500T	630-500	192	62	61	22.860	1	C

Reducer - Short Spigot - Continued

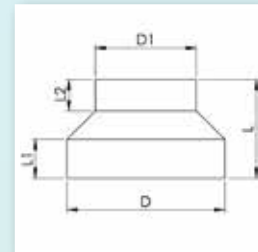

- PE100
- SDR 9 - Water PN20
- SDR 26 - Water PN6
- d250x160 - 1200x1000

Code	D-D1	L	L1	L2	Weight	Box Quantity	Delivery Code
	mm	mm	mm	mm	Kg		
PE100 SDR 9 Water PN 20							
SSRHK250X160R	250-160	157	55	55	2.460	1	C
SSRHK250X180R	250-180	150	62	50	2.230	1	C
SSRHK250X200R	250-200	138	60	50	2.300	1	C
SSRHK250X225R	250-225	142	50	68	2.140	1	C
SSRHK280X200R	280-200	160	72	51	3.220	1	C
SSRHK280X225R	280-225	154	72	57	3.290	1	C
SSRHK280X250R	280-250	150	71	64	3.320	1	C
SSRHK315X225R	315-225	184	82	57	4.670	1	C
SSRHK315X250R	315-250	178	81	62	4.640	1	C
SSRHK315X280R	315-280	175	79	72	5.140	1	C
SSRHK355X250R	355-250	195	87	62	6.000	1	C
SSRHK355X280R	355-280	200	87	77	6.400	1	C
SSRHK355X315R	355-315	188	88	78	6.500	1	C
SSRHK400X280R	400-280	226	96	73	8.670	1	C
SSRHK400X315R	400-315	218	97	83	8.840	1	C
SSRHK400X355R	400-355	208	97	92	9.080	1	C
SSRHK450X315R	450-315	206	64	76	9.540	1	C
SSRHK450X355R	450-355	203	64	92	9.980	1	C
SSRHK450X400R	450-400	188	64	99	10.350	1	C
SSRHK500X355R	500-355	210	62	81	12.020	1	C
SSRHK500X450R	500-450	166	63	63	11.530	1	C
SSRHK560X400R	560-400	240	60	98	17.320	1	C
SSRHK630X500R	630-500	192	62	61	19.980	1	C
PE100 SDR 26 Water PN 6							
SSRHK250X160W	250-160	157	55	55	1.000	1	C
SSRHK250X180W	250-180	150	62	50	1.000	1	C
SSRHK250X200W	250-200	138	60	50	1.000	1	C
SSRHK250X225W	250-225	142	50	68	1.000	1	C
SSRHK280X200W	280-200	160	72	51	1.490	1	C
SSRHK280X225W	280-225	154	72	57	1.480	1	C
SSRHK280X250W	280-250	150	71	64	1.330	1	C
SSRHK315X225W	315-225	184	82	57	2.120	1	C
SSRHK315X250W	315-250	178	81	62	1.970	1	C
SSRHK315X280W	315-280	175	79	72	1.860	1	C
SSRHK355X225W	355-225	213	92	57	2.650	1	C
SSRHK355X250W	355-250	195	87	62	2.530	1	C
SSRHK355X280W	355-280	200	87	77	3.100	1	C
SSRHK355X315W	355-315	188	88	78	3.000	1	C
SSRHK400X280W	400-280	226	96	73	4.340	1	C
SSRHK400X315W	400-315	218	97	83	4.300	1	C
SSRHK400X355W	400-355	208	97	92	4.100	1	C
SSRHK450X315W	450-315	206	64	76	4.600	1	C
SSRHK450X355W	450-355	203	64	92	4.600	1	C
SSRHK450X400W	450-400	188	64	99	4.600	1	C
SSRHK500X355W	500-355	210	62	81	5.900	1	C
SSRHK500X400W	500-400	210	63	96	6.300	1	C
SSRHK500X450W	500-450	166	63	63	6.000	1	C
SSRHK560X400W	560-400	240	60	98	8.400	1	C
SSRHK560X450W	560-450	187	60	65	7.600	1	C
SSRHK560X500W	560-500	192	62	61	6.900	1	C
SSRHK630X450W	630-450	234	60	68	10.600	1	C
SSRHK630X500W	630-500	192	62	61	11.420	1	C
SSRHK630X560W	630-560	188	64	65	9.900	1	C
SSRHK710X560W	710-560	160	66	40	13.800	1	C
SSRHK710X630W	710-630	160	66	62	12.100	1	C
SSRHK800X710W	800-710	160	62	62	14.300	1	C
SSRHK900X800W	900-800	160	62	62	18.600	1	C
SSRHK1000X900W	1000-900	170	65	56	22.000	1	C
SSRK1200X1000W	1200-1000	165	58	45	32.700	1	C

Note: Every effort has been made to ensure the information in this brochure is correct at the date of issue. Fusion operates a policy of continuous product improvement and range extension and, therefore, reserves the right to modify product specifications in line with market requirements. All dimensions in this catalogue are nominal. For more information visit our website www.fusiongroup.com

Reducer - Short Spigot - Continued

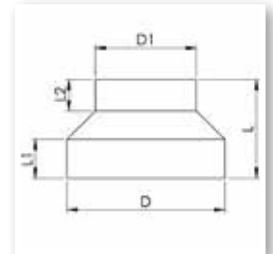

- PE100
- SDR 33 - Water PN5
- d200x140 - 1200x1000

Code	D-D1	L	L1	L2	Weight	Box Quantity	Delivery Code
	mm	mm	mm	mm	Kg		
PE100 SDR 33 Water PN 5							
SSRHK200X140Y	200-140	-	-	-	-	1	C
SSRHK200X160Y	200-160	-	-	-	-	1	C
SSRHK200X180Y	200-180	-	-	-	-	1	C
SSRHK225X140Y	225-140	-	-	-	-	1	C
SSRHK225X160Y	225-160	-	-	-	-	1	C
SSRHK225X180Y	225-180	-	-	-	-	1	C
SSRHK225X200Y	225-200	-	-	-	-	1	C
SSRHK250X160Y	250-160	180	75	63	0.900	1	C
SSRHK250X180Y	250-180	180	75	66	0.900	1	C
SSRHK250X200Y	250-200	180	75	72	0.900	1	C
SSRHK250X225Y	250-225	180	75	83	1.000	1	C
SSRHK280X180Y	280-180	200	85	70	1.200	1	C
SSRHK280X200Y	280-200	200	85	72	1.300	1	C
SSRHK280X225Y	280-225	200	85	80	1.300	1	C
SSRHK280X250Y	280-250	200	85	90	1.400	1	C
SSRHK315X200Y	315-200	231	95	85	1.700	1	C
SSRHK315X225Y	315-225	231	95	88	1.800	1	C
SSRHK315X250Y	315-250	231	95	95	1.900	1	C
SSRHK315X280Y	315-280	231	95	107	2.000	1	C
SSRHK355X225Y	355-225	140	57	40	1.500	1	C
SSRHK355X250Y	355-250	130	54	40	1.400	1	C
SSRHK355X280Y	355-280	120	53	40	1.400	1	C
SSRHK355X315Y	355-315	110	53	40	1.300	1	C
SSRHK400X225Y	400-225	160	64	40	2.200	1	C
SSRHK400X250Y	400-250	150	61	40	2.100	1	C
SSRHK400X280Y	400-280	140	60	40	2.000	1	C
SSRHK400X315Y	400-315	120	50	40	1.800	1	C
SSRHK400X355Y	400-355	110	51	40	1.600	1	C
SSRHK450X280Y	450-280	160	65	40	2.900	1	C
SSRHK450X315Y	450-315	140	55	40	2.600	1	C
SSRHK450X355Y	450-355	130	57	40	2.400	1	C
SSRHK450X400Y	450-400	120	60	40	2.300	1	C
SSRHK500X315Y	500-315	170	71	40	3.900	1	C
SSRHK500X355Y	500-355	150	62	40	3.500	1	C
SSRHK500X400Y	500-400	140	65	40	3.300	1	C
SSRHK500X450Y	500-450	120	60	40	2.800	1	C
SSRHK560X355Y	560-355	170	65	40	4.900	1	C
SSRHK560X400Y	560-400	160	68	40	4.700	1	C
SSRHK560X450Y	560-450	140	62	40	4.200	1	C
SSRHK560X500Y	560-500	130	67	40	3.900	1	C
SSRHK630X400Y	630-400	190	78	40	7.100	1	C
SSRHK630X450Y	630-450	170	72	40	6.400	1	C
SSRHK630X500Y	630-500	150	67	40	5.700	1	C
SSRHK630X560Y	630-560	130	64	40	4.900	1	C
SSRHK710X500Y	710-500	190	84	40	9.200	1	C
SSRHK710X560Y	710-560	170	81	40	8.300	1	C
SSRHK710X630Y	710-630	140	71	40	6.800	1	C
SSRHK800X560Y	800-560	200	85	40	12.500	1	C
SSRHK800X630Y	800-630	180	85	40	11.300	1	C
SSRHK800X710Y	800-710	150	78	40	9.300	1	C
SSRHK900X630Y	900-630	220	96	40	17.600	1	C
SSRHK900X710Y	900-710	190	89	40	15.300	1	C
SSRHK900X800Y	900-800	160	85	40	12.700	1	C
SSRHK1000X710Y	1000-710	220	91	40	22.100	1	C
SSRHK1000X800Y	1000-800	190	86	40	19.100	1	C
SSRHK1000X900Y	1000-900	150	75	40	14.700	1	C
SSRK1200X1000Y	1200-1000	190	92	40	28.400	1	C



Step Reducer - Short Spigot

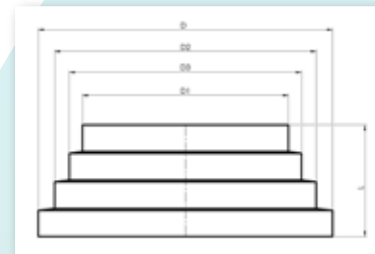

- PE100
- SDR 11 - Water PN16 / Gas 10 Bar
- SDR17 - Water PN10 / Gas 6 Bar
- d225x160 - 900x630

Code	D-D1 mm	D mm	D2 mm	D3 mm	D1 mm	L mm	Weight Kg	Box Quantity	Delivery Code
PE100 SDR 11 Water PN 16 Gas 10 Bar									
SSSRHK225X160N	225-160	225	180	200	160	171	1.700	1	A
SSSRHK315X225N	315-225	315	250	280	225	171	3.700	1	A
SSSRHK450X315N	450-315	450	355	400	315	176	8.300	1	A
SSSRHK630X450N	630-450	630	500	560	450	200	19.300	1	A
PE100 SDR 17 Water PN 10 Gas 6 Bar									
SSSRHK225X160V	225-160	225	180	200	160	171	1.300	1	A
SSSRHK315X225V	315-225	315	250	280	225	171	2.500	1	A
SSSRHK450X315V	450-315	450	355	400	315	180	5.800	1	A
SSSRHK630X450V	630-450	630	500	560	450	208	14.000	1	A
SSSRHK900X630V	900-630	900	710	800	630	194	31.000	1	A



Eccentric Reducer



- PE100
- SDR 11 - Water PN16
- d160x90 - 630x560

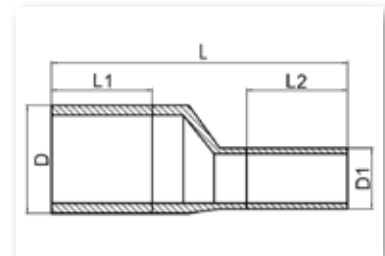

Code	D-D1	L	Weight	Box Quantity	Delivery Code
	mm	mm	Kg		
PE100 SDR 11 Water PN 16					
SPREHK160X90N	160-90	440	2.100	1	C
SPREHK160X110N	160-110	420	2.100	1	C
SPREHK160X125N	160-125	410	2.300	1	C
SPREHK160X140N	160-140	400	2.400	1	C
SPREHK180X110N	180-110	440	2.700	1	C
SPREHK180X125N	180-125	430	2.800	1	C
SPREHK180X140N	180-140	420	2.900	1	C
SPREHK180X160N	180-160	400	3.100	1	C
SPREHK200X125N	200-125	454	3.500	1	C
SPREHK200X140N	200-140	430	3.500	1	C
SPREHK200X160N	200-160	420	3.700	1	C
SPREHK200X180N	200-180	400	3.800	1	C
SPREHK225X140N	225-140	460	4.500	1	C
SPREHK225X160N	225-160	440	4.600	1	C
SPREHK225X180N	225-180	420	4.700	1	C
SPREHK225X200N	225-200	410	4.900	1	C
SPREHK250X160N	250-160	570	7.400	1	C
SPREHK250X180N	250-180	550	7.500	1	C
SPREHK250X200N	250-200	530	7.600	1	C
SPREHK250X225N	250-225	510	7.800	1	C
SPREHK280X180N	280-180	580	9.500	1	C
SPREHK280X200N	280-200	560	9.600	1	C
SPREHK280X225N	280-225	540	9.700	1	C
SPREHK280X250N	280-250	620	11.600	1	C
SPREHK315X200N	315-200	640	13.600	1	C
SPREHK315X225N	315-225	620	13.700	1	C
SPREHK315X250N	315-250	700	15.400	1	C
SPREHK315X280N	315-280	680	16.100	1	C
SPREHK355X225N	355-225	660	17.800	1	C
SPREHK355X250N	355-250	740	19.500	1	C
SPREHK355X280N	355-280	700	19.600	1	C
SPREHK355X315N	355-315	730	21.800	1	C
SPREHK400X250N	400-250	781	25.000	1	C
SPREHK400X280N	400-280	750	25.100	1	C
SPREHK400X315N	400-315	770	26.900	1	C
SPREHK400X355N	400-355	740	28.100	1	C
SPREHK450X280N	450-280	801	32.600	1	C
SPREHK450X315N	450-315	821	34.200	1	C
SPREHK450X355N	450-355	790	35.200	1	C
SPREHK450X400N	450-400	750	36.100	1	C
SPREHK500X280N	500-280	861	42.700	1	C
SPREHK500X315N	500-315	911	45.600	1	C
SPREHK500X355N	500-355	880	46.500	1	C
SPREHK500X400N	500-400	850	47.800	1	C
SPREHK500X450N	500-450	810	49.000	1	C
SPREHK560X400N	560-400	901	60.100	1	C
SPREHK560X450N	560-450	860	60.900	1	C
SPREHK560X500N	560-500	870	65.100	1	C
SPREHK630X450N	630-450	921	78.200	1	C
SPREHK630X500N	630-500	931	82.000	1	C
SPREHK630X560N	630-560	880	83.300	1	C

Eccentric Reducer - Continued

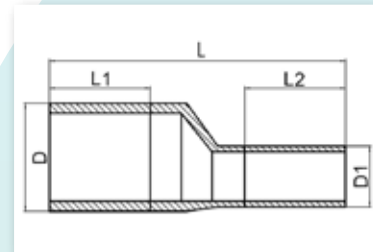

- PE100
- SDR 17 - Water PN10
- d160x90 - 1000x900

Code	D-D1	L	Weight	Box Quantity	Delivery Code
	mm	mm	Kg		
PE100 SDR 17 Water PN 10					
SPREHK160X90V	160-90	440	1.400	1	C
SPREHK160X110V	160-110	420	1.400	1	C
SPREHK160X125V	160-125	410	1.500	1	C
SPREHK160X140V	160-140	400	1.600	1	C
SPREHK180X110V	180-110	440	1.800	1	C
SPREHK180X125V	180-125	430	1.900	1	C
SPREHK180X140V	180-140	420	2.000	1	C
SPREHK180X160V	180-160	400	2.000	1	C
SPREHK200X125V	200-125	454	2.300	1	C
SPREHK200X140V	200-140	430	2.300	1	C
SPREHK200X160V	200-160	420	2.500	1	C
SPREHK200X180V	200-180	400	2.500	1	C
SPREHK225X140V	225-140	460	3.000	1	C
SPREHK225X160V	225-160	440	3.100	1	C
SPREHK225X180V	225-180	420	3.100	1	C
SPREHK225X200V	225-200	410	3.300	1	C
SPREHK250X160V	250-160	570	4.900	1	C
SPREHK250X180V	250-180	550	5.000	1	C
SPREHK250X200V	250-200	530	5.000	1	C
SPREHK250X225V	250-225	510	5.200	1	C
SPREHK280X180V	280-180	580	6.400	1	C
SPREHK280X200V	280-200	560	6.400	1	C
SPREHK280X225V	280-225	540	6.500	1	C
SPREHK280X250V	280-250	620	7.600	1	C
SPREHK315X200V	315-200	640	9.000	1	C
SPREHK315X225V	315-225	620	9.100	1	C
SPREHK315X250V	315-250	700	10.200	1	C
SPREHK315X280V	315-280	680	10.700	1	C
SPREHK355X225V	355-225	660	11.900	1	C
SPREHK355X250V	355-250	740	13.000	1	C
SPREHK355X280V	355-280	700	13.200	1	C
SPREHK355X315V	355-315	730	14.400	1	C
SPREHK400X250V	400-250	781	16.600	1	C
SPREHK400X280V	400-280	750	16.700	1	C
SPREHK400X315V	400-315	770	17.900	1	C
SPREHK400X355V	400-355	740	18.600	1	C
SPREHK450X280V	450-280	801	21.700	1	C
SPREHK450X315V	450-315	821	22.800	1	C
SPREHK450X355V	450-355	790	23.400	1	C
SPREHK450X400V	450-400	750	23.900	1	C
SPREHK500X280V	500-280	861	28.600	1	C
SPREHK500X315V	500-315	911	30.400	1	C
SPREHK500X355V	500-355	880	31.000	1	C
SPREHK500X400V	500-400	850	31.700	1	C
SPREHK500X450V	500-450	810	32.500	1	C
SPREHK560X400V	560-400	901	40.100	1	C
SPREHK560X450V	560-450	860	40.600	1	C
SPREHK560X500V	560-500	870	43.300	1	C
SPREHK630X450V	630-450	921	52.100	1	C
SPREHK630X500V	630-500	931	54.500	1	C
SPREHK630X560V	630-560	880	55.300	1	C
SPREHK710X560V	710-560	941	70.000	1	C
SPREHK710X630V	710-630	880	70.200	1	C
SPREHK800X630V	800-630	971	92.100	1	C
SPREHK800X710V	800-710	890	90.200	1	C
SPREHK900X710V	900-710	1031	124.600	1	C
SPREHK900X800V	900-800	960	124.200	1	C
SPREK1000X800V	1000-800	1051	159.600	1	C
SPREK1000X900V	1000-900	1020	163.500	1	C

Note: Every effort has been made to ensure the information in this brochure is correct at the date of issue. Fusion operates a policy of continuous product improvement and range extension and, therefore, reserves the right to modify product specifications in line with market requirements. All dimensions in this catalogue are nominal. For more information visit our website www.fusiongroup.com

Eccentric Reducer - Continued

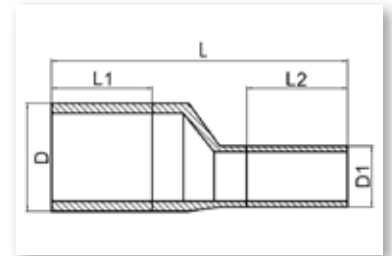

- PE100
- SDR 33 - Water PN5
- d160x90 - 1200x1000

Code	D-D1	L	Weight	Box Quantity	Delivery Code
	mm	mm	Kg		
PE100 SDR 33 Water PN 5					
SPREHK160X90Y	160-90	440	0.700	1	C
SPREHK160X110Y	160-110	420	0.800	1	C
SPREHK160X125Y	160-125	410	0.800	1	C
SPREHK160X140Y	160-140	400	0.900	1	C
SPREHK180X110Y	180-110	440	1.000	1	C
SPREHK180X125Y	180-125	430	1.000	1	C
SPREHK180X140Y	180-140	420	1.000	1	C
SPREHK180X160Y	180-160	400	1.100	1	C
SPREHK200X125Y	200-125	450	1.300	1	C
SPREHK200X140Y	200-140	430	1.300	1	C
SPREHK200X160Y	200-160	420	1.300	1	C
SPREHK200X180Y	200-180	400	1.400	1	C
SPREHK225X140Y	225-140	460	1.600	1	C
SPREHK225X160Y	225-160	440	1.600	1	C
SPREHK225X180Y	225-180	420	1.700	1	C
SPREHK225X200Y	225-200	410	1.800	1	C
SPREHK250X160Y	250-160	570	2.300	1	C
SPREHK250X180Y	250-180	550	2.400	1	C
SPREHK250X200Y	250-200	530	2.500	1	C
SPREHK250X225Y	250-225	510	2.700	1	C
SPREHK280X180Y	280-180	580	3.000	1	C
SPREHK280X200Y	280-200	560	3.100	1	C
SPREHK280X225Y	280-225	540	3.200	1	C
SPREHK280X250Y	280-250	620	4.100	1	C
SPREHK315X200Y	315-200	640	4.100	1	C
SPREHK315X225Y	315-225	620	4.200	1	C
SPREHK315X250Y	315-250	700	5.300	1	C
SPREHK315X280Y	315-280	680	5.600	1	C
SPREHK355X225Y	355-225	660	5.300	1	C
SPREHK355X250Y	355-250	740	6.700	1	C
SPREHK355X280Y	355-280	700	6.700	1	C
SPREHK355X315Y	355-315	730	7.700	1	C
SPREHK400X250Y	400-250	780	8.500	1	C
SPREHK400X280Y	400-280	750	8.600	1	C
SPREHK400X315Y	400-315	770	9.600	1	C
SPREHK400X355Y	400-355	740	10.000	1	C
SPREHK450X280Y	450-280	801	11.100	1	C
SPREHK450X315Y	450-315	820	12.200	1	C
SPREHK450X355Y	450-355	790	12.500	1	C
SPREHK450X400Y	450-400	750	12.800	1	C
SPREHK500X315Y	500-315	911	15.600	1	C
SPREHK500X355Y	500-355	880	16.000	1	C
SPREHK500X400Y	500-400	850	16.600	1	C
SPREHK500X450Y	500-450	810	17.100	1	C
SPREHK560X400Y	560-400	901	20.800	1	C
SPREHK560X450Y	560-450	860	21.200	1	C
SPREHK560X500Y	560-500	876	23.300	1	C
SPREHK630X450Y	630-450	921	27.000	1	C
SPREHK630X500Y	630-500	930	29.200	1	C
SPREHK630X560Y	630-560	880	29.600	1	C
SPREHK710X560Y	710-560	931	37.000	1	C
SPREHK710X630Y	710-630	874	37.300	1	C
SPREHK800X630Y	800-630	971	49.000	1	C
SPREHK800X710Y	800-710	890	48.000	1	C
SPREHK900X710Y	900-710	1031	65.400	1	C
SPREHK900X800Y	900-800	960	65.100	1	C
SPREK1000X800Y	1000-800	970	77.800	1	C
SPREK1000X900Y	1000-900	1091	92.800	1	C
SPREK1200X100Y	1200-1000	-	-	1	C

Note: Every effort has been made to ensure the information in this brochure is correct at the date of issue. Fusion operates a policy of continuous product improvement and range extension and, therefore, reserves the right to modify product specifications in line with market requirements. All dimensions in this catalogue are nominal. For more information visit our website www.fusiongroup.com

Eccentric Reducer - Short Spigot

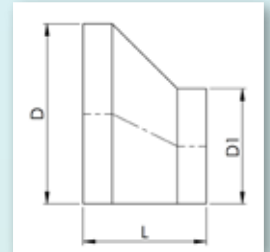

- PE100
- SDR 11 - Water PN16
- d160x90 - 630x560

Code	D-D1	L	Weight	Box Quantity	Delivery Code
	mm	mm	Kg		
PE100 SDR 11 Water PN 16					
SSREHK160X90N	160-90	140	0.700	1	C
SSREHK160X110N	160-110	120	0.600	1	C
SSREHK160X125N	160-125	110	0.600	1	C
SSREHK160X140N	160-140	100	0.600	1	C
SSREHK180X110N	180-110	140	0.900	1	C
SSREHK180X125N	180-125	130	0.900	1	C
SSREHK180X140N	180-140	120	0.900	1	C
SSREHK180X160N	180-160	100	0.800	1	C
SSREHK200X125N	200-125	154	1.300	1	C
SSREHK200X140N	200-140	130	1.100	1	C
SSREHK200X160N	200-160	120	1.100	1	C
SSREHK200X180N	200-180	100	1.000	1	C
SSREHK225X140N	225-140	160	1.700	1	C
SSREHK225X160N	225-160	140	1.500	1	C
SSREHK225X180N	225-180	120	1.400	1	C
SSREHK225X200N	225-200	110	1.300	1	C
SSREHK250X160N	250-160	170	2.300	1	C
SSREHK250X180N	250-180	150	2.100	1	C
SSREHK250X200N	250-200	130	1.900	1	C
SSREHK250X225N	250-225	110	1.700	1	C
SSREHK280X180N	280-180	180	3.000	1	C
SSREHK280X200N	280-200	160	2.800	1	C
SSREHK280X225N	280-225	140	2.500	1	C
SSREHK280X250N	280-250	120	2.300	1	C
SSREHK315X200N	315-200	190	4.100	1	C
SSREHK315X225N	315-225	170	3.800	1	C
SSREHK315X250N	315-250	150	3.500	1	C
SSREHK315X280N	315-280	130	3.100	1	C
SSREHK355X225N	355-225	210	5.800	1	C
SSREHK355X250N	355-250	190	5.400	1	C
SSREHK355X280N	355-280	160	4.500	1	C
SSREHK355X315N	355-315	130	4.000	1	C
SSREHK400X250N	400-250	231	8.100	1	C
SSREHK400X280N	400-280	200	9.500	1	C
SSREHK400X315N	400-315	170	7.800	1	C
SSREHK400X355N	400-355	140	6.300	1	C
SSREHK450X280N	450-280	251	11.200	1	C
SSREHK450X315N	450-315	220	13.600	1	C
SSREHK450X355N	450-355	190	11.500	1	C
SSREHK450X400N	450-400	150	7.500	1	C
SSREHK500X280N	500-280	261	14.400	1	C
SSREHK500X315N	500-315	260	20.100	1	C
SSREHK500X355N	500-355	230	17.500	1	C
SSREHK500X400N	500-400	200	14.900	1	C
SSREHK500X450N	500-450	160	11.400	1	C
SSREHK560X400N	560-400	251	18.400	1	C
SSREHK560X450N	560-450	210	19.700	1	C
SSREHK560X500N	560-500	170	13.300	1	C
SSREHK630X450N	630-450	271	25.300	1	C
SSREHK630X500N	630-500	250	27.400	1	C
SSREHK630X560N	630-560	180	17.900	1	C

Eccentric Reducer – Short Spigot - Continued

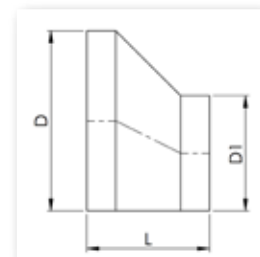

- PE100
- SDR 17 - Water PN10
- d160x90 - 1000x900

Code	D-D1	L	Weight	Box Quantity	Delivery Code
	mm	mm	Kg		
PE100 SDR 17 Water PN 10					
SSREHK160X90V	160-90	140	0.500	1	C
SSREHK160X110V	160-110	120	0.400	1	C
SSREHK160X125V	160-125	110	0.400	1	C
SSREHK160X140V	160-140	100	0.400	1	C
SSREHK180X110V	180-110	140	0.600	1	C
SSREHK180X125V	180-125	130	0.600	1	C
SSREHK180X140V	180-140	120	0.600	1	C
SSREHK180X160V	180-160	100	0.500	1	C
SSREHK200X125V	200-125	154	0.900	1	C
SSREHK200X140V	200-140	130	0.800	1	C
SSREHK200X160V	200-160	120	0.700	1	C
SSREHK200X180V	200-180	100	0.700	1	C
SSREHK225X140V	225-140	160	1.200	1	C
SSREHK225X160V	225-160	140	1.100	1	C
SSREHK225X180V	225-180	120	0.900	1	C
SSREHK225X200V	225-200	110	0.900	1	C
SSREHK250X160V	250-160	170	1.600	1	C
SSREHK250X180V	250-180	150	1.400	1	C
SSREHK250X200V	250-200	130	1.300	1	C
SSREHK250X225V	250-225	110	1.100	1	C
SSREHK280X180V	280-180	180	2.100	1	C
SSREHK280X200V	280-200	160	1.900	1	C
SSREHK280X225V	280-225	140	1.800	1	C
SSREHK280X250V	280-250	120	1.600	1	C
SSREHK315X200V	315-200	190	2.800	1	C
SSREHK315X225V	315-225	170	2.600	1	C
SSREHK315X250V	315-250	150	2.400	1	C
SSREHK315X280V	315-280	130	2.100	1	C
SSREHK355X225V	355-225	210	4.000	1	C
SSREHK355X250V	355-250	190	3.800	1	C
SSREHK355X280V	355-280	160	3.300	1	C
SSREHK355X315V	355-315	130	2.700	1	C
SSREHK400X250V	400-250	231	5.600	1	C
SSREHK400X280V	400-280	200	7.600	1	C
SSREHK400X315V	400-315	170	6.000	1	C
SSREHK400X355V	400-355	130	4.100	1	C
SSREHK450X280V	450-280	251	7.800	1	C
SSREHK450X315V	450-315	210	9.900	1	C
SSREHK450X355V	450-355	180	8.100	1	C
SSREHK450X400V	450-400	150	5.100	1	C
SSREHK500X280V	500-280	261	10.000	1	C
SSREHK500X315V	500-315	260	13.600	1	C
SSREHK500X355V	500-355	220	12.800	1	C
SSREHK500X400V	500-400	190	10.600	1	C
SSREHK500X450V	500-450	140	6.900	1	C
SSREHK560X400V	560-400	251	12.800	1	C
SSREHK560X450V	560-450	200	13.900	1	C
SSREHK560X500V	560-500	170	9.300	1	C
SSREHK630X450V	630-450	271	17.600	1	C
SSREHK630X500V	630-500	240	19.700	1	C
SSREHK630X560V	630-560	180	12.300	1	C
SSREHK710X560V	710-560	241	20.500	1	C
SSREHK710X630V	710-630	180	15.700	1	C
SSREHK800X630V	800-630	271	29.400	1	C
SSREHK800X710V	800-710	190	21.100	1	C
SSREHK900X710V	900-710	281	38.300	1	C
SSREHK900X800V	900-800	210	29.700	1	C
SSREK1000X800V	1000-800	301	51.900	1	C
SSREK1000X900V	1000-900	220	38.600	1	C

Eccentric Reducer – Short Spigot - Continued

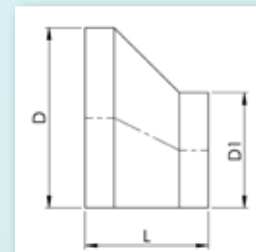

- PE100
- SDR33 - Water PN5
- d160x90 - 1200x1000

Code	D-D1	L	Weight	Box Quantity	Delivery Code
	mm	mm	Kg		
PE100 SDR 33 Water PN 5					
SSREHK160X90Y	160-90	140	0.300	1	C
SSREHK160X110Y	160-110	120	0.200	1	C
SSREHK160X125Y	160-125	110	0.200	1	C
SSREHK160X140Y	160-140	100	0.200	1	C
SSREHK180X110Y	180-110	140	0.300	1	C
SSREHK180X125Y	180-125	130	0.300	1	C
SSREHK180X140Y	180-140	120	0.300	1	C
SSREHK180X160Y	180-160	100	0.300	1	C
SSREHK200X125Y	200-125	150	0.500	1	C
SSREHK200X140Y	200-140	130	0.400	1	C
SSREHK200X160Y	200-160	120	0.400	1	C
SSREHK200X180Y	200-180	100	0.400	1	C
SSREHK225X140Y	225-140	160	0.600	1	C
SSREHK225X160Y	225-160	140	0.600	1	C
SSREHK225X180Y	225-180	120	0.500	1	C
SSREHK225X200Y	225-200	110	0.500	1	C
SSREHK250X160Y	250-160	170	0.900	1	C
SSREHK250X180Y	250-180	150	0.800	1	C
SSREHK250X200Y	250-200	130	0.700	1	C
SSREHK250X225Y	250-225	110	0.600	1	C
SSREHK280X180Y	280-180	180	1.100	1	C
SSREHK280X200Y	280-200	160	1.000	1	C
SSREHK280X225Y	280-225	140	0.900	1	C
SSREHK280X250Y	280-250	120	0.800	1	C
SSREHK315X200Y	315-200	190	1.500	1	C
SSREHK315X225Y	315-225	170	1.400	1	C
SSREHK315X250Y	315-250	150	1.300	1	C
SSREHK315X280Y	315-280	130	1.200	1	C
SSREHK355X225Y	355-225	210	2.200	1	C
SSREHK355X250Y	355-250	190	2.000	1	C
SSREHK355X280Y	355-280	150	1.600	1	C
SSREHK355X315Y	355-315	130	1.500	1	C
SSREHK400X250Y	400-250	230	3.100	1	C
SSREHK400X280Y	400-280	200	2.700	1	C
SSREHK400X315Y	400-315	160	5.000	1	C
SSREHK400X355Y	400-355	120	2.400	1	C
SSREHK450X280Y	450-280	251	4.200	1	C
SSREHK450X315Y	450-315	210	8.340	1	C
SSREHK450X355Y	450-355	170	5.400	1	C
SSREHK450X400Y	450-400	150	2.800	1	C
SSREHK500X280Y	500-280	291	5.900	1	C
SSREHK500X315Y	500-315	260	15.020	1	C
SSREHK500X355Y	500-355	220	10.100	1	C
SSREHK500X400Y	500-400	180	7.100	1	C
SSREHK500X450Y	500-450	130	4.160	1	C
SSREHK560X400Y	560-400	251	6.900	1	C
SSREHK560X450Y	560-450	190	9.400	1	C
SSREHK560X500Y	560-500	140	5.600	1	C
SSREHK630X450Y	630-450	271	9.500	1	C
SSREHK630X500Y	630-500	210	13.500	1	C
SSREHK630X560Y	630-560	180	6.600	1	C
SSREHK710X560Y	710-560	231	10.600	1	C
SSREHK710X630Y	710-630	174	8.200	1	C
SSREHK800X630Y	800-630	271	15.600	1	C
SSREHK800X710Y	800-710	190	11.100	1	C
SSREHK900X710Y	900-710	281	20.700	1	C
SSREHK900X800Y	900-800	210	15.400	1	C
SSREK1000X800Y	1000-800	220	22.100	1	C
SSREK1000X900Y	1000-900	291	26.300	1	C
SSREK1200X100Y	1200-1000	-	-	1	C

Note: Every effort has been made to ensure the information in this brochure is correct at the date of issue. Fusion operates a policy of continuous product improvement and range extension and, therefore, reserves the right to modify product specifications in line with market requirements. All dimensions in this catalogue are nominal. For more information visit our website www.fusiongroup.com

End Cap

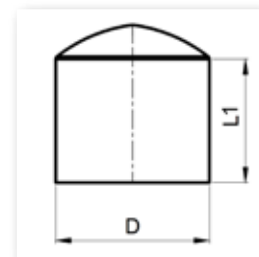

- PE100
- SDR 11 - Water PN 16 / Gas 10 Bar
- SDR 17 - Water PN10 / Gas 6 Bar
- d20-1200

* Extended with PE 100 Pipe

Code	D	L1	Weight	Box Quantity	Delivery Code
	mm	mm	Kg		
PE100 SDR 11 Water PN 16 Gas 10 Bar					
LSECHK20N	20	41	0.008	100	A
LSECHK25N	25	41	0.012	100	A
LSECHK32N	32	44	0.016	100	A
LSECHK40N	40	49	0.028	60	A
LSECHK50N	50	55	0.048	50	A
LSECHK63N	63	63	0.088	36	A
LSECHK75N	75	70	0.142	27	A
LSECHK90N	90	79	0.234	60	A
LSECHK110N	110	82	0.374	36	A
LSECHK125N	125	87	0.542	24	A
LSECHK140N	140	92	0.748	22	A
LSECHK160N	160	98	1.022	15	A
LSECHK180N	180	105	1.416	8	A
LSECHK200N	200	112	1.888	10	A
LSECHK225N	225	120	2.520	4	A
LSECHK250N	250	129	3.240	4	A
LSECHK280N	280	139	4.580	3	A
LSECHK315N	315	150	6.310	2	A
LSECHK355N	355	164	8.700	1	A
LSECHK400N	400	179	12.440	1	A
LSECHK450N	*450	300	27.200	1	A
LSECHK500N	*500	350	38.500	1	A
LSECHK560N	*560	350	50.500	1	A
LSECHK630N	*630	350	64.900	1	A
PE100 SDR 17 Water PN 10 Gas 6 Bar					
LSECHK50V	50	55	0.034	50	A
LSECHK63V	63	63	0.079	36	A
LSECHK75V	75	70	0.117	27	A
LSECHK90V	90	79	0.205	60	A
LSECHK110V	110	82	0.308	36	A
LSECHK125V	125	87	0.436	24	A
LSECHK140V	140	92	0.621	22	A
LSECHK160V	160	98	0.863	15	A
LSECHK180V	180	105	1.135	8	A
LSECHK200V	200	112	1.518	10	A
LSECHK225V	225	120	2.113	4	A
LSECHK250V	250	129	2.764	4	A
LSECHK280V	280	139	3.761	3	A
LSECHK315V	315	150	5.191	2	A
LSECHK355V	355	164	7.465	1	A
LSECHK400V	400	179	10.640	1	A
LSECHK450V	*450	300	21.100	1	A
LSECHK500V	*500	350	29.000	1	A
LSECHK560V	*560	350	38.500	1	A
LSECHK630V	*630	350	52.300	1	A
LSECHK710V	*710	350	70.000	1	A
LSECHK800V	*800	350	95.800	1	A
LSECHK900V	*900	400	136.800	1	A
LSECHK1000V	*1000	400	179.700	1	A
LSECHK1200V	*1200	400	261.100	1	A

End Cap - Continued

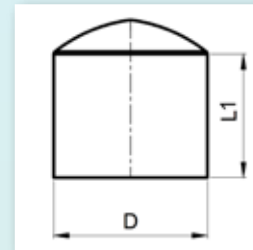

- PE100
- SDR 7.4 - Water PN25
- SDR9 - Water PN20
- d25-315

Code	D	L1	Weight	Box Quantity	Delivery Code
	mm	mm	Kg		
PE100 SDR 7.4 Water PN 25					
LSECHK25T	25	49	-	150	B
LSECHK32T	32	51	0.030	150	B
LSECHK40T	40	61	0.040	80	B
LSECHK50T	50	58	0.080	130	B
LSECHK63T	63	71	0.140	76	B
LSECHK75T	75	78	0.200	48	B
LSECHK90T	90	81	0.300	32	B
LSECHK110T	110	93	0.530	45	B
LSECHK125T	125	89	0.670	36	B
LSECHK140T	140	104	0.970	33	B
LSECHK160T	160	117	1.520	14	B
LSECHK180T	180	103	1.780	12	B
LSECHK200T	200	132	2.640	6	B
LSECHK225T	225	118	3.100	6	B
LSECHK250T	250	117	3.890	6	B
LSECHK280T	280	136	4.360	3	B
LSECHK315T	315	156	4.650	33	B
PE100 SDR 9 Water PN 20					
LSECHK63R	63	71	0.130	76	B
LSECHK75R	75	78	0.190	48	B
LSECHK90R	90	81	0.290	32	B
LSECHK110R	110	93	0.500	45	B
LSECHK125R	125	89	0.640	36	B
LSECHK140R	140	104	0.920	33	B
LSECHK160R	160	117	1.440	14	B
LSECHK180R	180	103	1.690	12	B
LSECHK200R	200	132	2.510	6	B
LSECHK225R	225	118	2.950	6	B
LSECHK250R	250	117	3.700	6	B
LSECHK280R	280	136	4.140	3	B
LSECHK315R	315	156	4.420	33	B

End Cap - Short Spigot



- PE100
- SDR 11 - Water PN16 / (Gas 10 Bar - Upon request)
- SDR 17 - Water PN10 / (Gas 6 Bar - Upon request)
- SDR 7.4 - Water PN25
- SDR9 - Water PN20
- SDR33 - Water PN5
- d250-1200

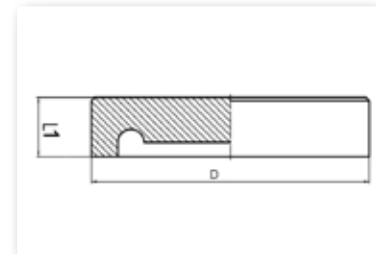

Code	D	L1	Weight	Box Quantity	Delivery Code
	mm	mm	Kg		
PE100 SDR 11 Water PN 16 (Gas 10 Bar - Upon request)					
SSECHK250N	250	55	2.650	1	A
SSECHK280N	280	20	3.200	1	A
SSECHK315N	315	20	4.400	1	A
SSECHK355N	355	20	6.500	1	A
SSECHK400N	400	20	8.800	1	A
SSECHK450N	450	20	12.600	1	A
SSECHK500N	500	20	17.300	1	A
SSECHK560N	560	20	24.000	1	A
SSECHK630N	630	30	34.100	1	A
SSECHK710N	710	-	-	1	A
SSECHK800N	800	-	-	1	A
PE100 SDR 17 Water PN 10 (Gas 6 Bar - Upon request)					
SSECHK250V	250	50	1.660	1	A
SSECHK280V	280	20	2.800	1	A
SSECHK315V	315	20	3.900	1	A
SSECHK355V	355	20	5.400	1	A
SSECHK400V	400	20	7.400	1	A
SSECHK450V	450	20	10.900	1	A
SSECHK500V	500	20	14.300	1	A
SSECHK560V	560	20	20.100	1	A
SSECHK630V	630	30	28.900	1	A
SSECHK710V	710	-	-	1	A
SSECHK800V	800	-	-	1	A
SSECHK900V	900	30	82.400	1	A
SSECHK1000V	1000	30	112.400	1	A
SSECHK1200V	1200	92	164.400	1	A
PE100 SDR 7.4 Water PN 25					
SSECHK355T	355	-	8.920	1	C
SSECHK400T	400	-	12.320	1	C
SSECHK450T	450	-	16.650	1	C
SSECHK500T	500	-	22.020	1	C
SSECHK560T	560	-	-	1	C
SSECHK630T	630	-	-	1	C
PE100 SDR 9 Water PN 20					
SSECHK355R	355	-	8.030	1	C
SSECHK400R	400	-	11.120	1	C
SSECHK450R	450	-	14.980	1	C
SSECHK500R	500	-	19.820	1	C
SSECHK560R	560	-	-	1	C
SSECHK630R	630	-	-	1	C
PE100 SDR 33 Water PN 5					
SSECHK280Y	280	20	2.100	1	C
SSECHK315Y	315	20	2.700	1	C
SSECHK355Y	355	20	3.800	1	C
SSECHK400Y	400	20	5.500	1	C
SSECHK450Y	450	20	7.600	1	C
SSECHK500Y	500	20	10.300	1	C
SSECHK560Y	560	20	15.200	1	C
SSECHK630Y	630	30	21.000	1	C
SSECHK710Y	710	30	30.200	1	C
SSECHK800Y	800	30	43.000	1	C
SSECHK900Y	900	30	60.200	1	C
SSECHK1000Y	1000	30	81.200	1	C
SSECHK1200Y	1200	92	109.600	1	C

Stub Flange Adaptor

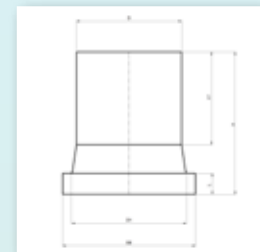

- PE100
- SDR 11 - Water PN16 / Gas 10 Bar
- SDR 17 - Water PN10 / Gas 6 Bar
- d20-1200

* Short spigot - extended with PE100 Pipe

Code	D	D1	D2	L	L1	A	Weight	Box	Delivery
	mm	mm	mm	mm	mm	mm	Kg	Quantity	Code
PE100 SDR 11 Water PN 16 Gas 10 Bar									
SFHK20N	20	28	45	7	55	80	0.024	100	A
SFHK25N	25	34	58	9	62	81	0.038	50	A
SFHK32N	32	42	68	10	61	86	0.052	40	A
SFHK40N	40	51	78	11	60	88	0.082	70	A
SFHK50N	50	62	88	12	63	92	0.122	50	A
SFHK63N	63	78	102	14	88	120	0.200	60	A
SFHK75N	75	92	122	16	97	130	0.310	60	A
SFHK90N	90	108	138	17	103	140	0.440	45	A
SFHK110N	110	125	158	18	113	155	0.680	24	A
SFHK125N	125	135	158	20	120	159	0.780	16	A
SFHK140N	140	155	188	25	128	190	1.318	12	A
SFHK160N	160	175	212	25	155	200	1.620	12	A
SFHK180N	180	188	212	30	152	207	1.960	10	A
SFHK200N	200	232	268	32	153	210	2.680	4	A
SFHK225N	225	238	268	32	129	180	3.108	4	A
SFHK250N	250	288	320	35	140	205	3.782	2	A
SFHK280N	280	288	320	35	145	211	4.724	2	A
SFHK315N	315	338	375	35	160	224	6.346	2	A
SFHK355N	355	376	435	45	172	240	9.188	1	A
SFHK400N	400	430	485	50	181	264	12.700	1	A
SFHK450NE	450(DN500)	514	585	60	200	306	22.900	1	A
SFHK450NP	*450	465	545	66	195	360	21.770	1	A
SFHK500N	500	530	585	60	250	346	26.300	1	A
SFHK500NP	*500	530	590	60	212	354	25.060	1	A
SFHK560N	560	615	685	60	290	400	39.700	1	A
SFHK560NP	*560	618	690	80	235	423	38.800	1	A
SFHK630N	630	642	685	60	300	390	42.500	1	A
SFHK630NP	*630	645	690	65	255	404	42.400	1	A
SFHK710N	710	737	800	60	330	430	61.400	1	A
SFHK800N	800	840	905	65	380	482	88.600	1	A
PE100 SDR 17 Water PN 10 Gas 6 Bar									
SFHK50V	50	60	88	12	62	90	0.106	10	A
SFHK63V	63	78	102	14	88	120	0.160	60	A
SFHK75V	75	92	122	16	97	130	0.272	60	A
SFHK90V	90	108	139	17	106	140	0.350	45	A
SFHK110V	110	125	158	17	113	155	0.530	24	A
SFHK125V	125	135	158	20	120	160	0.570	16	A
SFHK140V	140	155	188	18	128	188	1.108	12	A
SFHK160V	160	175	212	18	147	185	1.070	12	A
SFHK180V	180	188	212	20	111	153	1.110	12	A
SFHK200V	200	230	268	24	125	188	1.912	4	A
SFHK225V	225	238	268	24	156	205	2.316	4	A
SFHK250V	250	288	320	25	133	186	2.841	2	A
SFHK280V	280	288	320	25	148	213	3.958	2	A
SFHK315V	315	338	375	25	166	223	4.470	2	A
SFHK355V	355	376	435	30	174	227	6.062	1	A
SFHK400V	400	430	485	33	185	242	8.328	1	A
SFHK450VE	450(DN500)	514	585	46	195	301	16.500	1	A
SFHK450VP	*450	465	545	45	195	335	14.260	1	A
SFHK500V	500	530	585	46	212	308	16.900	1	A
SFHK500VP	*500	530	590	46	212	339	16.880	1	A
SFHK560V	560	615	685	50	235	345	25.600	1	A
SFHK560VP	*560	618	690	50	235	373	24.170	1	A
SFHK630V	630	642	685	50	300	390	29.400	1	A
SFHK630VP	*630	645	690	50	255	384	28.420	1	A
SFHK710V	710	737	800	50	325	425	42.400	1	A
SFHK800V	800	840	905	52	360	462	58.500	1	A
SFHK900V	900	944	1005	55	360	485	77.200	1	A
SFHK1000V	1000	1047	1110	60	395	525	102.200	1	A
SFHK1200V	1200	1245	1330	70	500	600	165.100	1	A

Note: Every effort has been made to ensure the information in this brochure is correct at the date of issue. Fusion operates a policy of continuous product improvement and range extension and, therefore, reserves the right to modify product specifications in line with market requirements. All dimensions in this catalogue are nominal. For more information visit our website www.fusiongroup.com

Stub Flange Adaptor - Continued

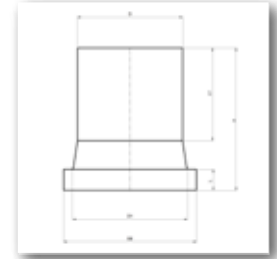

- PE100
- SDR 7.4 - Water PN25
- SDR9 - Water PN20
- d25-315

Code	D mm	D1 mm	D2 mm	L mm	L1 mm	A mm	Weight Kg	Box Quantity	Delivery Code
PE100 SDR 7.4 Water PN 25									
SFHK25T	25	-	-	-	-	-	0.050	70	B
SFHK32T	32	40	68	11	56	82	0.060	50	B
SFHK40T	40	50	78	12	56	80	0.140	30	B
SFHK50T	50	61	88	13	55	87	0.160	100	B
SFHK63T	63	75	102	16	63	101	0.240	60	B
SFHK75T	75	89	122	18	73	113	0.390	40	B
SFHK90T	90	105	138	20	82	126	0.580	30	B
SFHK110T	110	125	158	21	91	138	0.910	24	B
SFHK125T	125	134	158	28	101	152	1.090	20	B
SFHK140T	140	155	188	29	102	164	1.590	12	B
SFHK160T	160	175	212	29	106	168	2.150	12	B
SFHK180T	180	180	212	32	108	178	2.450	6	B
SFHK200T	200	232	268	34	119	200	3.980	75	B
SFHK225T	225	235	268	34	120	193	4.240	70	B
SFHK250T	250	285	320	37	129	202	6.520	50	B
SFHK280T	280	291	320	42	140	210	6.840	40	B
SFHK315T	315	335	370	47	157	230	9.930	24	B
PE100 SDR 9 Water PN 20									
SFHK63R	63	75	102	16	63	101	0.220	60	B
SFHK75R	75	89	122	18	73	113	0.340	40	B
SFHK90R	90	105	138	20	82	126	0.490	30	B
SFHK110R	110	125	158	21	91	138	0.790	24	B
SFHK125R	125	134	158	28	101	152	0.970	20	B
SFHK140R	140	155	188	29	102	164	1.400	12	B
SFHK160R	160	175	212	29	106	168	1.780	12	B
SFHK180R	180	180	212	32	108	178	2.200	6	B
SFHK200R	200	232	268	34	119	200	3.720	75	B
SFHK225R	225	235	268	34	120	193	3.830	70	B
SFHK250R	250	285	320	37	129	202	5.440	50	B
SFHK280R	280	291	320	42	140	210	6.100	40	B
SFHK315R	315	335	370	47	157	230	8.430	24	B

Stub Flange Adaptor – Chamfered (Suitable for Butterfly Valves)

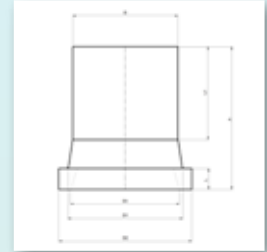

- PE100
- SDR 11 - Water PN16 / Gas 10 Bar
- SDR 17 - Water PN10 / Gas 6 Bar
- d160-1000

* Short spigot - extended with PE100 Pipe

Code	D mm	D1 mm	D2 mm	D3 mm	L mm	L1 mm	A mm	Weight Kg	Box Quantity	Delivery Code
PE100 SDR 11 Water PN 16 Gas 10 Bar										
SFHK160NBF	160	175	212	154	25	155	200	1.620	12	A
SFHK180NBF	180	188	212	158	30	152	207	1.960	10	A
SFHK200NBF	200	232	268	208	32	153	210	2.680	4	A
SFHK225NBF	225	238	268	208	32	129	180	3.108	4	A
SFHK250NBF	250	288	320	260	35	140	205	3.782	2	A
SFHK280NBF	280	288	320	260	35	145	211	4.724	2	A
SFHK315NBF	315	338	375	305	35	160	224	6.346	2	A
SFHK355NBF	355	376	435	345	45	172	240	9.188	1	A
SFHK400NBF	400	430	485	396	50	181	264	12.700	1	A
SFHK450NBF	*450	465	545	442	66	195	360	21.770	1	A
SFHK450NBFEP	*450 (DN500)	517	585	480	65	195	360	22.890	1	A
SFHK500NBF	*500	530	590	494	60	212	354	25.060	1	A
SFHK560NBF	*560	618	690	580	80	235	423	38.800	1	A
SFHK630NBF	*630	645	690	576	65	255	404	42.400	1	A
SFHK710NBF	*710									
Product available on request										
PE100 SDR 17 Water PN 10 Gas 6 Bar										
SFHK160VBF	160	175	212	154	18	147	185	1.070	12	A
SFHK180VBF	180	188	212	164	20	111	153	1.110	12	A
SFHK200VBF	200	230	268	208	24	125	188	1.912	4	A
SFHK225VBF	225	238	268	208	24	156	205	2.316	4	A
SFHK250VBF	250	288	320	260	25	133	186	2.841	2	A
SFHK280VBF	280	288	320	260	25	148	213	3.958	2	A
SFHK315VBF	315	338	375	305	25	166	223	4.470	2	A
SFHK355VBF	355	376	435	350	30	174	227	6.062	1	A
SFHK400VBF	400	430	485	396	33	185	242	8.328	1	A
SFHK450VBF	*450	465	545	442	45	195	335	14.260	1	A
SFHK450VBFEP	*450 (DN500)	517	585	485	45	195	335	15.120	1	A
SFHK500VBF	*500	530	590	497	46	212	339	16.880	1	A
SFHK560VBF	*560	618	690	580	50	235	373	24.170	1	A
SFHK630VBF	*630	645	690	585	50	255	384	28.420	1	A
SFHK710VBF	*710									
SFHK800VBF	*800									Available upon request
SFHK900VBF	*900									Available upon request
SFHK1000VBF	*1000									Available upon request



Stub Flange Adaptor - ANSI



- PE100
- SDR 11 - Water PN16 / Gas 10 Bar
- SDR17 - Water PN10 / Gas 6 Bar
- d20-630

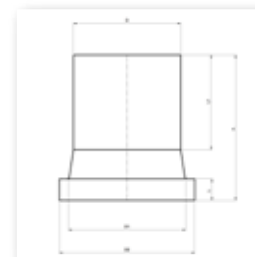

Code	D mm	D1 mm	D2 mm	L mm	L1 mm	A mm	Weight Kg	Box Quantity	Delivery Code
PE100 SDR 11 Water PN 16 Gas 10 Bar									
SFHK20NA	20	28	45	7	55	80	0.024	100	A
SFHK25NA	25	34	54	9	62	81	0.038	50	A
SFHK32NA	32	42	64	10	61	86	0.052	40	A
SFHK40NA	40	51	73	11	60	88	0.072	70	A
SFHK50NA	50	62	82	12	63	92	0.122	50	A
SFHK63NA	63	78	100	14	88	120	0.190	60	A
SFHK75NA	75	92	119	16	97	130	0.300	60	A
SFHK90NA	90	108	132	17	103	140	0.420	45	A
SFHK110NA	110	125	158	18	113	155	0.68	24	A
SFHK450NAP	450	465	545	66	195	360	21.77	1	A
SFHK500NAP	500	530	590	60	212	354	25.06	1	A
SFHK560NAP	560	580	654	80	235	423	38.4	1	A
SFHK630NAP	630	650	710	65	255	404	43.5	1	A
PE100 SDR 17 Water PN 10 Gas 6 Bar									
SFHK63VA	63	78	100	14	88	120	0.160	60	A
SFHK75VA	75	92	119	16	97	130	0.240	60	A
SFHK90VA	90	108	132	17	106	140	0.330	45	A
SFHK110VA	110	125	158	17	113	155	0.53	24	A
SFHK450VAP	450	465	545	45	195	335	14.26	1	A
SFHK500VAP	500	530	590	46	212	339	16.88	1	A
SFHK560VAP	560	580	654	80	235	423	24.17	1	A
SFHK630VAP	630	650	710	50	255	404	29.4	1	A

Stub Flange Adaptor - Short Spigot

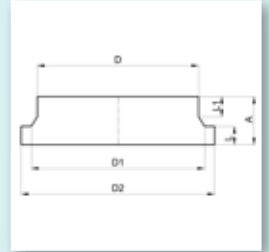

- PE100
- SDR 11 - Water PN16 / Gas 10 Bar
- SDR 17 - Water PN10 / Gas 6 Bar
- d20-1200

Code	D mm	D1 mm	D2 mm	L mm	L1 mm	A mm	Weight Kg	Box Quantity	Delivery Code
PE100 SDR 11 Water PN 16 Gas 10 Bar									
SSSFHK20N	20	27	45	7	30	52	0.019	100	A
SSSFHK25N	25	33	58	9	27	53	0.035	50	A
SSSFHK32N	32	40	68	10	28	52	0.047	40	A
SSSFHK40N	40	50	78	11	25	51	0.066	25	A
SSSFHK50N	50	61	88	12	30	56	0.087	15	A
SSSFHK63N	63	75	102	14	23	60	0.160	100	A
SSSFHK75N	75	89	122	16	25	67	0.240	50	A
SSSFHK90N	90	105	138	17	26	70	0.310	45	A
SSSFHK110N	110	125	158	18	25	74	0.460	40	A
SSSFHK125N	125	132	158	25	31	71	0.500	28	A
SSSFHK140N	140	155	188	25	30	86	0.560	24	A
SSSFHK160N	160	175	212	25	25	84	1.010	24	A
SSSFHK180N	180	180	212	30	34	97	1.280	10	A
SSSFHK200N	200	232	268	32	50	120	1.860	6	A
SSSFHK225N	225	238	268	32	53	120	1.980	6	A
SSSFHK250N	250	288	320	35	45	120	2.640	3	A
SSSFHK280N	280	288	320	35	46	120	2.871	3	A
SSSFHK315N	315	338	375	35	47	120	3.730	4	A
SSSFHK355N	355	376	435	45	45	120	5.300	2	A
SSSFHK400N	400	430	485	50	40	124	6.740	2	A
SSSFHK450N	450	465	545	66	40	140	11.520	1	A
SSSFHK450NE	450 (DN500)	517	585	65	40	160	12.640	1	A
SSSFHK500N	500	530	590	60	40	134	11.280	1	A
SSSFHK560N	560	618	690	80	43	180	19.710	1	A
SSSFHK630N	630	645	690	65	45	140	16.160	1	A
SSSFHK710N	710	737	800	75	35	150	27.680	9	A
SSSFHK800N	800	840	905	80	30	150	35.680	7	A
SSSFHK900N	900	944	1110	90	28	158	46.610	7	A
SSSFHK1000N	1000	-	-	-	-	-	-	1	A
SSSFHK1200N	1200	-	-	-	-	-	-	1	A
PE100 SDR 17 Water PN 10 Gas 6 Bar									
SSSFHK50V	50	61	88	30	12	56	0.079	15	A
SSSFHK63V	63	75	102	14	27	64	0.140	100	A
SSSFHK75V	75	89	122	16	27	67	0.220	50	A
SSSFHK90V	90	105	138	17	26	68	0.300	45	A
SSSFHK110V	110	125	158	18	25	73	0.400	30	A
SSSFHK125V	125	132	158	18	30	71	0.390	28	A
SSSFHK140V	140	155	188	18	30	80	0.530	24	A
SSSFHK160V	160	175	212	18	25	75	0.670	24	A
SSSFHK180V	180	180	212	20	30	87	0.810	10	A
SSSFHK200V	200	230	268	24	57	120	1.390	6	A
SSSFHK225V	225	238	268	24	61	120	1.450	6	A
SSSFHK250V	250	288	320	25	55	120	1.940	3	A
SSSFHK280V	280	288	320	25	56	120	2.090	3	A
SSSFHK315V	315	338	375	25	57	120	2.720	4	A
SSSFHK355V	355	376	435	30	60	120	3.800	2	A
SSSFHK400V	400	430	485	33	52	120	4.710	2	A
SSSFHK450V	450	465	545	45	40	134	7.300	1	A
SSSFHK450VE	450 (DN500)	517	585	45	40	134	8.160	1	A
SSSFHK500V	500	530	590	46	45	120	7.540	1	A
SSSFHK560V	560	618	690	50	36	130	11.210	1	A
SSSFHK630V	630	645	690	50	45	120	10.600	1	A
SSSFHK710V	710	737	800	52	45	138	17.300	10	A
SSSFHK800V	800	840	905	53	40	125	24.140	8	A
SSSFHK900V	900	944	1005	59	40	130	29.500	7	A
SSSFHK1000V	1000	1047	1110	65	40	135	36.800	1	A
SSSFHK1100V	1100	-	-	-	-	-	-	1	A
SSSFHK1200V	1200	1245	1330	70	40	140	52.400	1	A



Stub Flange Adaptor - Short Spigot - Continued

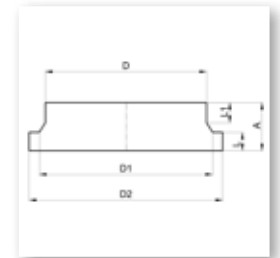

- PE100
- SDR 7.4 - Water PN25
- SDR9 - Water PN20
- SDR26 - Water PN6
- d160-1200

Code	D mm	D1 mm	D2 mm	L mm	L1 mm	A mm	Weight Kg	Box Quantity	Delivery Code
PE100 SDR 7.4 Water PN 25									
SSSFHK280T	280	291	320	42	66	138	4.350	74	C
SSSFHK315T	315	335	370	47	77	155	7.470	48	C
SSSFHK355T	355	373	430	53	52	146	8.310	40	C
SSSFHK400T	400	427	482	60	33	133	9.720	28	C
SSSFHK450TE	450 (DN500)	514	658	67	60	160	19.720	18	C
SSSFHK500T	500	-	-	-	-	-	-	1	C
SSSFHK560T	560	-	-	-	-	-	-	1	C
SSSFHK630T	630	-	-	-	-	-	-	1	C
PE100 SDR 9 Water PN 20									
SSSFHK280R	280	291	320	42	66	138	4.000	74	C
SSSFHK315R	315	335	370	47	77	155	6.000	48	C
SSSFHK355R	355	373	430	53	52	146	7.210	40	C
SSSFHK400R	400	427	482	60	33	133	9.500	28	C
SSSFHK450RE	450 (DN500)	514	658	67	60	160	16.290	18	C
SSSFHK500R	500	-	-	-	-	-	-	1	C
SSSFHK560R	560	-	-	-	-	-	-	1	C
SSSFHK630R	630	-	-	-	-	-	-	1	C
PE100 SDR 26 Water PN 6									
SSSFHK160W	160	175	206	14	25	70	0.610	24	C
SSSFHK180W	180	184	206	16	30	86	0.500	16	C
SSSFHK200W	200	232	261	19	41	108	1.130	7	C
SSSFHK225W	225	235	261	19	32	99	0.890	8	C
SSSFHK250W	250	285	316	20	38	109	1.620	6	C
SSSFHK280W	280	291	316	20	63	114	1.500	74	C
SSSFHK315W	315	335	372	20	64	119	2.400	54	C
SSSFHK355W	355	373	422	24	51	118	3.750	45	C
SSSFHK400W	400	427	472	26	46	118	3.660	28	C
SSSFHK450WE	450 (DN500)	514	577	36	63	140	9.180	18	C
SSSFHK500W	500	520	577	36	72	137	6.790	20	C
SSSFHK560W	560	615	678	40	54	132	10.780	13	C
SSSFHK630W	630	642	678	40	46	121	8.020	13	C
SSSFHK710W	710	737	782	42	40	125	12.240	10	C
SSSFHK800W	800	840	888	43	30	120	15.600	8	C
SSSFHK900W	900	944	988	47	40	130	20.520	7	C
SSSFHK1000W	1000	1047	1088	52	40	130	24.400	1	C
SSSFHK1100W	1100	1150	1234	40	40	153	-	1	C
SSSFHK1200W	1200	1245	1305	63	35	153	-	1	C

Stub Flange Adaptor - Short Spigot - Continued

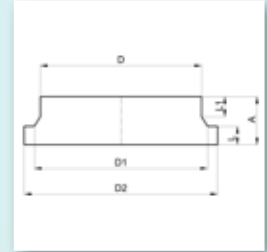

- PE100
- SDR33 - Water PN5
- d110-1200

Code	D	D1	D2	L	L1	A	Weight	Box Quantity	Delivery Code
	mm	mm	mm	mm	mm	mm	Kg		
PE100 SDR 33 Water PN 5									
SSSFHK110Y	110	125	158	18	37	83	0.310	16	C
SSSFHK125Y	125	132	158	18	44	87	0.308	14	C
SSSFHK140Y	140	155	188	18	35	83	0.420	12	C
SSSFHK160Y	160	175	212	18	43	95	0.575	8	C
SSSFHK180Y	180	184	212	18	62	TBC	0.535	8	C
SSSFHK200Y	200	232	268	18	60	121	1.260	8	C
SSSFHK225Y	225	235	268	18	65	121	0.960	8	C
SSSFHK250Y	250	285	320	20	60	119	1.765	5	C
SSSFHK280Y	280	291	320	20	71	118	1.375	5	C
SSSFHK315Y	315	335	370	20	86	165	2.490	3	C
SSSFHK355Y	355	373	430	23	100	180	3.590	4	C
SSSFHK400Y	400	427	482	26	100	195	5.440	2	C
SSSFHK450YE	450	514	585	33	60	139	7.470	2	C
SSSFHK500Y	500	530	585	38	60	138	6.560	2	C
SSSFHK560Y	560	615	685	40	60	139	9.840	10	C
SSSFHK630Y	630	642	685	35	45	120	6.400	1	C
SSSFHK710Y	710	737	800	35	35	120	9.700	1	C
SSSFHK800Y	800	840	905	36	34	120	12.900	1	C
SSSFHK900Y	900	944	1005	40	30	140	18.300	1	C
SSSFHK1000Y	1000	1047	1110	42	28	140	22.300	1	C
SSSFHK1100Y	1100	-	-	-	-	-	-	1	C
SSSFHK1200Y	1200	1245	1330	50	60	140	31.500	1	C

Stub Flange Adaptor – Chamfered - Short Spigot (Suitable for Butterfly Valves)

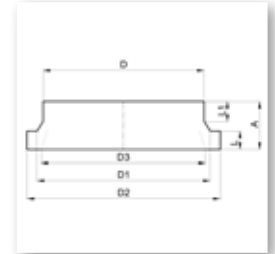

- PE100
- SDR 11 - Water PN16 / Gas 10 Bar
- SDR17- Water PN10 / Gas 6 Bar
- d200-1000

Code	D mm	D1 mm	D2 mm	D3 mm	L mm	L1 mm	A mm	Weight Kg	Box Quantity	Delivery Code
PE100 SDR 11 Water PN 16 Gas 10 Bar										
SSSFHK200NBF	200	232	268	208	32	50	120	1.860	6	A
SSSFHK225NBF	225	238	268	208	32	53	120	1.980	6	A
SSSFHK250NBF	250	288	320	260	35	45	120	2.640	3	A
SSSFHK280NBF	280	288	320	260	35	46	120	2.871	3	A
SSSFHK315NBF	315	338	375	305	35	47	120	3.730	4	A
SSSFHK355NBF	355	376	435	345	45	45	120	5.300	2	A
SSSFHK400NBF	400	430	485	396	50	40	124	6.740	2	A
SSSFHK450NBF	450	465	545	442	66	40	140	11.520	1	A
SSSFHK450NBFE	450 (DN500)	517	585	480	65	40	160	12.640	1	A
SSSFHK500NBF	500	530	590	494	60	40	134	11.280	1	A
SSSFHK560NBF	560	618	690	580	80	43	180	19.710	1	A
SSSFHK630NBF	630	645	690	576	65	45	140	16.160	1	A
SSSFHK710NBF	710	740	800	663	75	40	154	24.150	1	A
PE100 SDR 17 Water PN 10 Gas 6 Bar										
SSSFHK200VBF	200	230	268	208	24	57	120	1.390	6	A
SSSFHK225VBF	225	238	268	208	24	61	120	1.450	6	A
SSSFHK250VBF	250	288	320	260	25	55	120	1.940	3	A
SSSFHK280VBF	280	288	320	260	25	56	120	2.090	3	A
SSSFHK315VBF	315	338	375	305	25	57	120	2.720	4	A
SSSFHK355VBF	355	376	435	350	30	60	120	3.800	2	A
SSSFHK400VBF	400	430	485	396	33	52	120	4.710	2	A
SSSFHK450VBF	450	465	545	442	45	40	134	7.300	1	A
SSSFHK450VBFE	450 (DN500)	517	585	485	45	40	134	8.160	1	A
SSSFHK500VBF	500	530	590	497	46	45	120	7.540	1	A
SSSFHK560VBF	560	618	690	580	50	36	130	11.210	1	A
SSSFHK630VBF	630	645	690	585	50	45	120	10.600	1	A
SSSFHK710VBF	710	740	800	670	50	40	130	15.610	1	A
SSSFHK800VBF	800	843	905	780	60	45	140	20.450	1	A
SSSFHK900VBF	900	947	1005	884	60	45	150	25.550	1	A
SSSFHK1000VBF	1000	1050	1112	972	65	45	165	35.070	1	A

Stub Flange Adaptor - ANSI - Short Spigot

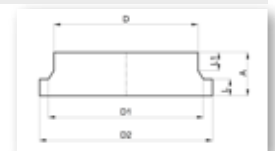

- PE100
- SDR 11 - Water PN16 / Gas 10 Bar
- SDR17- Water PN10 / Gas 6 Bar
- d450-630

Code	D mm	D1 mm	D2 mm	L mm	L1 mm	A mm	Weight Kg	Box Quantity	Delivery Code
PE100 SDR 11 Water PN 16 Gas 10 Bar									
SSSFHK450NA	450	465	545	66	40	140	11.52	1	A
SSSFHK500NA	500	530	590	60	40	134	11.28	1	A
SSSFHK560NA	560	580	654	80	43	180	19.200	1	A
SSSFHK630NA	630	650	710	65	45	140	16.600	1	A
PE100 SDR 17 Water PN 10 Gas 6 Bar									
SSSFHK450VA	450	465	545	45	40	134	7.3	1	A
SSSFHK500VA	500	530	590	46	45	120	7.54	1	A
SSSFHK560VA	560	580	654	80	43	180	12.930	1	A
SSSFHK630VA	630	650	710	50	45	120	11.200	1	A

Flange - Polypropylene with Steel Core

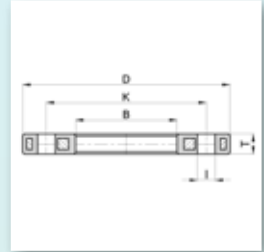

- EN1092-1 - PN 16 Drilling
- EN1092-1 - PN 10 Drilling
- ANSI B16.5 - C150 Drilling
- d20-630 (Pipe Diameter)

Sizes d710 and above available upon request

Code	Pipe Diameter	DN	D	B	K	T	Number of Holes	Inner Bolt Dimension	I	Bolt Diameter	Delivery Code
	mm	mm	mm	mm	mm	mm		mm	mm		
Polypropylene with Steel Core PN10 EN 1092-1 - Drilling											
PBR200X200NP10	200	200	340	235	295	27	8	273	22	M20	B
PBR225X200NP10	225	200	340	238	295	27	8	273	22	M20	B
PBR250X250NP10	250	250	395	288	350	30	12	328	22	M20	B
PBR280X250NP10	280	250	395	294	350	30	12	328	22	M20	B
PBR315X300NP10	315	300	445	338	400	34	12	378	22	M20	B
PBR355X350NP10	355	350	505	376	460	40	16	438	22	M20	B
PBR400X400NP10	400	400	565	430	515	40	16	489	26	M24	B
PBR450X500NP10	450	500	678	517	620	45	20	594	26	M24	B
PBR500X500NP10	500	500	670	533	620	45	20	594	26	M24	B
PBR560X600NP10	560	600	780	618	725	50	20	695	30	M27	B
PBR630X600NP10	630	600	780	645	725	50	20	695	30	M27	B
Polypropylene with Steel Core PN16 EN 1092-1											
PBR020X015NP16	20	15	95	28	65	12	4	51	14	M12	B
PBR025X020NP16	25	20	105	34	75	12	4	61	14	M12	B
PBR032X025NP16	32	25	115	42	85	16	4	71	14	M12	B
PBR040X032NP16	40	32	140	51	100	16	4	82	18	M16	B
PBR050X040NP16	50	40	150	62	110	18	4	92	18	M16	B
PBR063X050NP16	63	50	165	78	125	18	4	107	18	M16	B
PBR075X065NP16	75	65	188	92	145	18	4	127	18	M16	B
PBR090X080NP16	90	80	204	108	160	20	8	142	18	M16	B
PBR110X100NP16	110	100	224	128	180	20	8	162	18	M16	B
PBR125X100NP16	125	100	224	135	180	20	8	162	18	M16	B
PBR140X125NP16	140	125	252	158	210	24	8	192	18	M16	B
PBR160X150NP16	160	150	285	178	240	24	8	218	22	M20	B
PBR180X150NP16	180	150	285	188	240	24	8	218	22	M20	B
PBR200X200NP16	200	200	340	235	295	27	12	273	22	M20	B
PBR225X200NP16	225	200	340	238	295	27	12	273	22	M20	B
PBR250X250NP16	250	250	419	288	355	32	12	329	26	M24	B
PBR280X250NP16	280	250	419	294	355	32	12	329	26	M24	B
PBR315X300NP16	315	300	478	338	410	34	12	384	26	M24	B
PBR355X350NP16	355	350	532	376	470	42	16	444	26	M24	B
PBR400X400NP16	400	400	592	430	525	46	16	495	30	M27	B
PBR450X500NP16	450	500	715	517	650	46	20	617	33	M30	B
PBR500X500NP16	500	500	715	533	650	46	20	617	33	M30	B
PBR560X600NP16	560	600	840	618	770	55	20	734	36	M33	B
PBR630X600NP16	630	600	840	645	770	55	20	734	36	M33	B
Polypropylene with Steel Core ASTM B16.5 C150 Drilling											
PBR020X015A	20	15	95	28	60.5	12	4	44.5	16	M12	B
PBR025X020A	25	20	102	34	69.9	12	4	53.9	16	M12	B
PBR032X025A	32	25	114	42	79.3	16	4	63.3	16	M12	B
PBR040X032A	40	32	130	51	88.9	16	4	72.9	16	M12	B
PBR050X040A	50	40	133	62	98.6	18	4	82.6	16	M12	B
PBR063X050A	63	50	165	78	120.6	18	4	100.6	20	M16	B
PBR075X065A	75	65	184	92	139.7	18	4	119.7	20	M16	B
PBR090X080A	90	80	194	111	152.4	20	4	132.4	20	M16	B
PBR110X100A	110	100	229	133	190.5	20	8	170.5	20	M16	B
PBR160X150A	160	150	283	178	241.3	24	8	219.3	22	M20	B
PBR180X150A	180	150	285	188	241.3	24	8	219.3	22	M20	B
PBR200X200A	200	200	345	236	298.5	27	8	276.5	22	M20	B
PBR250X250A	250	250	412	288	361.9	32	12	329.9	32	M22	B
PBR315X300A	315	300	487	338	431.8	32	12	406.8	25	M22	B
PBR355X350A	355	350	533	376	476.2	42	12	447.7	28.5	M27	B
PBR400X400A	400	400	596	430	539.7	44	16	511.2	28.5	M27	B

Flange – Galvanised Steel / Stainless Steel

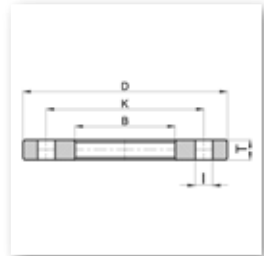
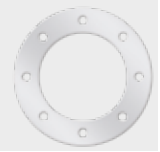

- EN1092 - PN16 Drilling
- EN1092 - PN10 Drilling
- ANSI B16.5 - C150 Drilling
- d20-630 (Pipe Diameter)

Galvanised Steel Code	Stainless Steel Code	Pipe Diameter	DN	D	B	K	T	Number of Holes	Inner Bolt Dimension	I	Bolt Diameter	Delivery Code
Galvanised Steel Stainless Steel PN10 EN 1092-1												
GBR200X200NP10	SBR200X200NP10	200	200	340	235	295	10	8	273	22	M20	C
GBR225X200NP10	SBR225X200NP10	225	200	340	238	295	10	8	273	22	M20	C
GBR250X250NP10	SBR250X250NP10	250	250	395	288	350	15	12	328	22	M20	C
GBR280X250NP10	SBR280X250NP10	280	250	395	294	350	15	12	328	22	M20	C
GBR315X300NP10	SBR315X300NP10	315	300	445	338	400	20	12	378	22	M20	C
GBR355X350NP10	SBR355X350NP10	355	350	505	376	460	20	16	438	22	M20	C
GBR400X400NP10	SBR400X400NP10	400	400	565	430	515	25	16	489	26	M24	C
GBR450X450NP10	SBR450X450NP10	450	450	615	465	565	25	20	539	26	M24	C
GBR450X500NP10	SBR450X500NP10	450	500	670	517	620	25	20	594	26	M24	C
GBR500X500NP10	SBR500X500NP10	500	500	670	533	620	25	20	594	26	M24	C
GBR560X600NP10	SBR560X600NP10	560	600	780	618	725	25	20	695	30	M27	C
GBR630X600NP10	SBR630X600NP10	630	600	780	645	725	25	20	695	30	M27	C
Galvanised Steel Stainless Steel PN16 EN 1092-1												
GBR020X015NP16	SBR020X015NP16	20	15	95	28	65	8	4	51	14	M12	C
GBR025X020NP16	SBR025X020NP16	25	20	105	34	75	8	4	61	14	M12	C
GBR032X025NP16	SBR032X025NP16	32	25	115	42	85	8	4	71	14	M12	C
GBR040X032NP16	SBR040X032NP16	40	32	140	51	100	8	4	82	18	M16	C
GBR050X040NP16	SBR050X040NP16	50	40	150	62	110	8	4	92	18	M16	C
GBR063X050NP16	SBR063X050NP16	63	50	165	78	125	8	4	107	18	M16	C
GBR075X065NP16	SBR075X065NP16	75	65	185	92	145	8	4	127	18	M16	C
GBR090X080NP16	SBR090X080NP16	90	80	200	108	160	8	8	142	18	M16	C
GBR110X100NP16	SBR110X100NP16	110	100	220	128	180	8	8	162	18	M16	C
GBR125X100NP16	SBR125X100NP16	125	100	220	135	180	8	8	162	18	M16	C
GBR140X125NP16	SBR140X125NP16	140	125	250	158	210	10	8	192	18	M16	C
GBR160X150NP16	SBR160X150NP16	160	150	285	178	240	10	8	218	22	M20	C
GBR180X150NP16	SBR180X150NP16	180	150	285	188	240	10	8	218	22	M20	C
GBR200X200NP16	SBR200X200NP16	200	200	340	235	295	10	12	273	22	M20	C
GBR225X200NP16	SBR225X200NP16	225	200	340	238	295	10	12	273	22	M20	C
GBR250X250NP16	SBR250X250NP16	250	250	405	288	355	15	12	329	26	M24	C
GBR280X250NP16	SBR280X250NP16	280	250	405	294	355	15	12	329	26	M24	C
GBR315X300NP16	SBR315X300NP16	315	300	460	338	410	20	12	384	26	M24	C
GBR355X350NP16	SBR355X350NP16	355	350	520	376	470	20	16	444	26	M24	C
GBR400X400NP16	SBR400X400NP16	400	400	580	430	525	25	16	495	30	M27	C
GBR450X450NP16	SBR450X450NP16	450	450	640	465	585	25	20	555	30	M27	C
GBR450X500NP16	SBR450X500NP16	450	500	715	517	650	25	20	617	33	M30	C
GBR500X500NP16	SBR500X500NP16	500	500	715	533	650	25	20	617	33	M30	C
GBR560X600NP16	SBR560X600NP16	560	600	840	618	770	25	20	734	36	M33	C
GBR630X600NP16	SBR630X600NP16	630	600	840	645	770	25	20	734	36	M33	C
Galvanised Steel Stainless Steel ASTM B16.5 C150 Drilling												
GBR020X015A	SBR020X015A	20	15	90	28	60.5	11.2	4	44.5	16	1/2"	C
GBR025X020A	SBR025X020A	25	20	98	34	70	12.8	4	54	16	1/2"	C
GBR032X025A	SBR032X025A	32	25	108	42	79.5	14.2	4	63.5	16	1/2"	C
GBR040X032A	SBR040X032A	40	32	117	51	89	15.7	4	73	16	1/2"	C
GBR050X040A	SBR050X040A	50	40	127	62	98.5	17.5	4	82.5	16	1/2"	C
GBR063X050A	SBR063X050A	63	50	152	78	120.5	19	4	100.5	20	5/8"	C
GBR075X065A	SBR075X065A	75	65	178	92	139.5	22.3	4	119.5	20	5/8"	C
GBR090X080A	SBR090X080A	90	80	191	108	152	23.9	4	132	20	5/8"	C
GBR110X100A	SBR110X100A	110	100	229	128	190.5	23.9	8	170.5	20	5/8"	C
GBR125X125A	SBR125X125A	125	125	254	140	216	23.9	8	194	22	3/4"	C
GBR140X125A	SBR140X125A	140	125	254	158	216	23.9	8	194	22	3/4"	C
GBR160X150A	SBR160X150A	160	150	279	178	241	25.4	8	219	22	3/4"	C
GBR180X150A	SBR180X150A	180	150	279	195	241	25.4	8	219	22	3/4"	C
GBR200X200A	SBR200X200A	200	200	343	235	298.5	28.4	8	276.5	22	3/4"	C
GBR225X200A	SBR225X200A	225	200	343	238	298.5	28.4	8	276.5	22	3/4"	C
GBR250X250A	SBR250X250A	250	250	406	288	362	30.2	12	336	26	7/8"	C
GBR280X250A	SBR280X250A	280	250	406	294	362	30.2	12	336	26	7/8"	C
GBR315X300A	SBR315X300A	315	300	483	345	432	31.8	12	406	26	7/8"	C
GBR355X350A	SBR355X350A	355	350	535	376	476	35	12	446	30	1"	C
GBR400X400A	SBR400X400A	400	400	600	430	540	36.6	16	510	30	1"	C
GBR450X450A	SBR450X450A	450	450	635	480	578	39.6	16	545	33	1.1/8"	C
GBR500X500A	SBR500X500A	500	500	700	533	635	43	20	602	33	1.1/8"	C
GBR560X600A	SBR560X600A	560	600	750	618	692	48	20	656	36	1.1/8"	C
GBR630X600A	SBR630X600A	630	600	815	660	750	47.8	20	714	36	1.1/4"	C

Note: Every effort has been made to ensure the information in this brochure is correct at the date of issue. Fusion operates a policy of continuous product improvement and range extension and, therefore, reserves the right to modify product specifications in line with market requirements. All dimensions in this catalogue are nominal. For more information visit our website www.fusiongroup.com

Flange – Galvanised Steel / Stainless Steel - Continued

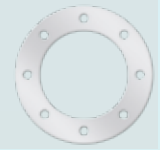

- AS2129 TABLE D AND AS4087 - Full Thickness
- AS2129 TABLE E
- AS2129 TABLE D AND AS4087 - Mining / Low Pressure
- d63-1000 (Pipe Diameter)

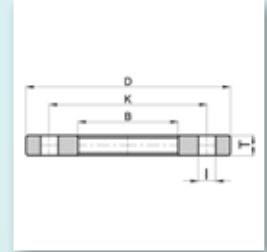

Galvanised Steel Code	Stainless Steel Code	Pipe Diameter	DN	D	B	K	T	Number of Holes	Inner Bolt Dimension	I	Bolt Diameter	Delivery Code
		mm	mm	mm	mm	mm	mm		mm	mm		
Galvanised Steel Stainless Steel AS2129 Table D/E/AS4087 Full Thickness												
GBR063X050ED16	SBR063X050ED16	63	50	150	78	114	11	4	96	18	M16	C
GBR075X065ED16	SBR075X065ED16	75	65	165	92	127	11	4	109	18	M16	C
GBR090X080ED16	SBR090X080ED16	90	80	185	108	146	11	4	128	18	M16	C
GBR110X100D16	SBR110X100D16	110	100	215	128	178	13	4	160	18	M16	C
GBR125X100D16	SBR125X100D16	125	100	215	140	178	13	4	160	18	M16	C
GBR125X125ED16	SBR125X125ED16	125	125	255	140	210	14	8	192	18	M16	C
GBR140X125ED16	SBR140X125ED16	140	125	255	158	210	14	8	192	18	M16	C
GBR160X150D16	SBR160X150D16	160	150	280	178	235	13	8	217	18	M16	C
GBR180X150D16	SBR180X150D16	180	150	280	195	235	13	8	217	18	M16	C
GBR200X200D16	SBR200X200D16	200	200	335	235	292	19	8	274	18	M16	C
GBR225X200D16	SBR225X200D16	225	200	335	240	292	19	8	274	18	M16	C
GBR250X250D16	SBR250X250D16	250	250	405	290	356	19	8	334	22	M20	C
GBR280X250D16	SBR280X250D16	280	250	405	300	356	19	8	334	22	M20	C
GBR315X300D16	SBR315X300D16	315	300	455	345	406	23	12	384	22	M20	C
GBR355X350ED16	SBR355X350ED16	355	350	525	376	470	30	12	444	26	M24	C
GBR400X400ED16	SBR400X400ED16	400	400	580	430	521	32	12	495	26	M24	C
GBR450X450D16	SBR450X450D16	450	450	640	480	584	30	12	558	26	M24	C
GBR500X500ED16	SBR500X500ED16	500	500	705	533	641	38	16	615	26	M24	C
GBR630X600D16	SBR630X600D16	630	600	825	660	756	48	16	726	30	M27	C
GBR710X700D16	SBR710X700D16	710	700	910	740	845	56	20	815	30	M27	C
GBR800X800D16	SBR800X800D16	800	800	1060	843	984	56	20	948	36	M33	C
GBR900X900D16	SBR900X900D16	900	900	1175	947	1092	66	24	1056	36	M33	C
GBR1000X1000D16	SBR1000X1000D16	1000	1000	1255	1050	1175	66	24	1139	36	M33	C
Galvanised Steel Stainless Steel AS2129 Table E												
GBR110X100E16	SBR110X100E16	110	100	215	128	178	13	8	160	18	M16	C
GBR125X100E16	SBR125X100E16	125	100	215	140	178	13	8	160	18	M16	C
GBR160X150E16	SBR160X150E16	160	150	280	178	235	17	8	213	22	M20	C
GBR180X150E16	SBR180X150E16	180	150	280	195	235	17	8	213	22	M20	C
GBR200X200E16	SBR200X200E16	200	200	335	235	292	19	8	270	22	M20	C
GBR225X200E16	SBR225X200E16	225	200	335	238	292	19	8	270	22	M20	C
GBR250X250E16	SBR250X250E16	250	250	405	290	356	22	12	334	22	M20	C
GBR280X250E16	SBR280X250E16	280	250	405	300	356	22	12	334	22	M20	C
GBR315X300E16	SBR315X300E16	315	300	455	345	406	25	12	380	26	M20	C
GBR450X450E16	SBR450X450E16	450	450	640	480	584	35	16	558	26	M24	C
GBR560X560E16	SBR560X560E16	560	560	760	590	699	44	16	669	30	M27	C
GBR630X600E16	SBR630X600E16	630	600	825	660	756	48	16	723	33	M30	C
GBR710X700E16	SBR710X700E16	710	700	910	740	845	51	20	812	33	M27	C
GBR800X800E16	SBR800X800E16	800	800	1060	843	984	54	20	948	36	M33	C
GBR900X900E16	SBR900X900E16	900	900	1175	947	1092	64	24	1056	36	M33	C
GBR1000X1000E16	SBR1000X1000E16	1000	1000	1255	1050	1175	67	24	1136	39	M36	C
Galvanised Steel Stainless Steel AS2129 Table D/AS4087 Mining / Low Pressure												
GBR315X300D10	SBR315X300D10	315	300	455	345	406	19	12	384	22	M20	C
GBR355X350D10	SBR355X350D10	355	350	525	376	470	22	12	444	26	M24	C
GBR400X400D10	SBR400X400D10	400	400	580	430	521	22	12	495	26	M24	C
GBR450X450D10	SBR450X450D10	450	450	640	480	584	25	12	558	26	M24	C
GBR500X500D10	SBR500X500D10	500	500	705	533	641	29	16	615	26	M24	C
GBR560X560D10	SBR560X560D10	560	560	760	590	699	29	16	669	30	M27	C
GBR630X600D10	SBR630X600D10	630	600	825	660	756	32	16	726	30	M27	C
GBR710X700D10	SBR710X700D10	710	700	910	740	845	35	20	815	30	M27	C
GBR800X800D10	SBR800X800D10	800	800	1060	843	984	41	20	948	36	M33	C
GBR900X900D10	SBR900X900D10	900	900	1175	947	1092	48	24	1056	36	M33	C
GBR1000X1000D10	SBR1000X1000D10	1000	1000	1255	1050	1175	51	24	1139	36	M33	C

Long Spigot Puddle Flange - EDPM



- PE100
- SDR11
- SDR17
- Water tight 3 Bar up to d315
- Water tight 1 Bar d355 and above
- d90-630

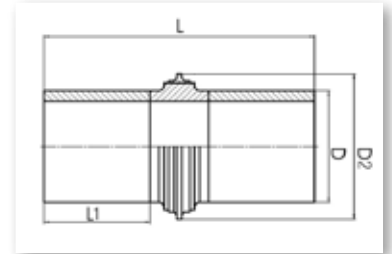

Code	D mm	D2 mm	L mm	L1 mm	Weight Kg	Box Quantity	Delivery Code
PE100 SDR11 EDPM Low Pressure Water							
PFHK90N	90	215	440	150	1.600	1	C
PFHK110N	110	230	440	150	2.100	1	C
PFHK125N	125	245	440	150	2.600	1	C
PFHK140N	140	265	440	150	3.100	1	C
PFHK160N	160	280	440	150	3.900	1	C
PFHK180N	180	305	440	150	4.800	1	C
PFHK200N	200	330	450	150	6.000	1	C
PFHK225N	225	355	450	150	7.400	1	C
PFHK250N	250	385	650	250	12.200	1	C
PFHK280N	280	420	650	250	15.100	1	C
PFHK315N	315	460	765	300	22.300	1	C
PFHK355N	355	480	775	300	28.300	1	C
PFHK400N	400	530	775	300	35.600	1	C
PFHK450N	450	580	775	300	44.400	1	C
PFHK500N	500	640	885	350	61.300	1	C
PFHK560N	560	710	915	350	76.700	1	C
PFHK630N	630	790	915	350	96.900	1	C
PE100 SDR17 EDPM Low Pressure Water							
PFHK90V	90	215	440	150	1.300	1	C
PFHK110V	110	230	440	150	1.600	1	C
PFHK125V	125	245	440	150	2.000	1	C
PFHK140V	140	265	440	150	2.400	1	C
PFHK160V	160	280	440	150	2.900	1	C
PFHK180V	180	305	440	150	3.600	1	C
PFHK200V	200	330	450	150	4.500	1	C
PFHK225V	225	355	450	150	5.500	1	C
PFHK250V	250	385	650	250	8.900	1	C
PFHK280V	280	420	650	250	10.900	1	C
PFHK315V	315	460	765	300	16.100	1	C
PFHK355V	355	480	775	300	20.400	1	C
PFHK400V	400	530	775	300	25.600	1	C
PFHK450V	450	580	775	300	31.700	1	C
PFHK500V	500	640	885	350	43.700	1	C
PFHK560V	560	710	915	350	54.700	1	C
PFHK630V	630	790	915	350	68.900	1	C

Full Face Gaskets - EDPM / NBR Duo

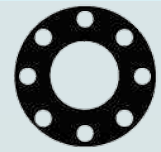

- EDPM - Water
- NBR - Gas
- EN1092 - PN16 - Drilling
- EN1092 - PN10 - Drilling
- d20-630
- Only for PE to PE connections - suitable for SDR 11 and SDR 17 Stub Flange Adaptors
- Profiled, aramid, PTFE, metallic / semi-metallic upon request

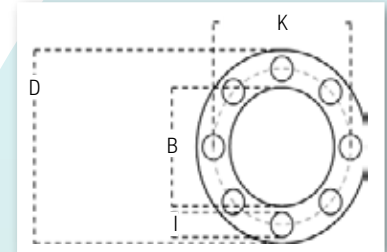

State specification details when ordering

*B (mm) - may vary depending upon specification

EDPM - WATER Code	NBR - GAS Code	Pipe Diameter	DN	D	B*	K	I	Number of Holes	Delivery Code
		mm	mm	mm	mm	mm	mm		
EDPM NBR PN10 EN 1092									
GFF200X200PN10W	GFF200X200PN10G	200	200	340	178	295	22	8	C
GFF225X200PN10W	GFF225X200PN10G	225	200	340	198	295	22	8	C
GFF250X250PN10W	GFF250X250PN10G	250	250	395	216	350	22	12	C
GFF280X250PN10W	GFF280X250PN10G	280	250	395	248	350	22	12	C
GFF315X300PN10W	GFF315X300PN10G	315	300	445	268	400	22	12	C
GFF355X350PN10W	GFF355X350PN10G	355	350	505	304	460	22	16	C
GFF400X400PN10W	GFF400X400PN10G	400	400	565	352	515	26	16	C
GFF450X450PN10W	GFF450X450PN10G	450	450	615	398	565	26	20	C
GFF450X500PN10W	GFF450X500PN10G	450	500	670	398	620	26	20	C
GFF500X500PN10W	GFF500X500PN10G	500	500	670	440	620	26	20	C
GFF560X600PN10W	GFF560X600PN10G	560	600	780	492	725	30	20	C
GFF630X600PN10W	GFF630X600PN10G	630	600	780	540	725	30	20	C
EDPM NBR PN16 EN 1092									
GFF20X15PN16W	GFF20X15PN16G	20	15	95	22	65	14	4	C
GFF25X20PN16W	GFF25X20PN16G	25	20	105	27	75	14	4	C
GFF32X25PN16W	GFF32X25PN16G	32	25	115	34	85	14	4	C
GFF40X32PN16W	GFF40X32PN16G	40	32	140	43	100	18	4	C
GFF50X40PN16W	GFF50X40PN16G	50	40	150	49	110	18	4	C
GFF63X50PN16W	GFF63X50PN16G	63	50	165	55	125	18	4	C
GFF75X65PN16W	GFF75X65PN16G	75	65	185	68	145	18	4	C
GFF90X80PN16W	GFF90X80PN16G	90	80	200	82	160	18	8	C
GFF110X100PN16W	GFF110X100PN16G	110	100	220	96	180	18	8	C
GFF125X100PN16W	GFF125X100PN16G	125	100	220	112	180	18	8	C
GFF140X125PN16W	GFF140X125PN16G	140	125	250	126	210	18	8	C
GFF160X150PN16W	GFF160X150PN16G	160	150	285	150	240	22	8	C
GFF180X150PN16W	GFF180X150PN16G	180	150	285	156	240	22	8	C
GFF200X200PN16W	GFF200X200PN16G	200	200	340	178	295	22	12	C
GFF225X200PN16W	GFF225X200PN16G	225	200	340	198	295	22	12	C
GFF250X250PN16W	GFF250X250PN16G	250	250	405	216	355	26	12	C
GFF280X250PN16W	GFF280X250PN16G	280	250	405	248	355	26	12	C
GFF315X300PN16W	GFF315X300PN16G	315	300	460	268	410	26	12	C
GFF355X350PN16W	GFF355X350PN16G	355	350	520	304	470	26	16	C
GFF400X400PN16W	GFF400X400PN16G	400	400	580	352	525	30	16	C
GFF450X450PN16W	GFF450X450PN16G	450	450	640	398	585	30	20	C
GFF450X500PN16W	GFF450X500PN16G	450	500	710	398	650	33	20	C
GFF500X500PN16W	GFF500X500PN16G	500	500	715	440	650	33	20	C
GFF560X600PN16W	GFF560X600PN16G	560	600	835	492	770	36	20	C
GFF630X600PN16W	GFF630X600PN16G	630	600	835	540	770	36	20	C

Full Face Gaskets - EDPM / NBR Duo - Continued



- EDPM - Water
- NBR - Gas
- ANSI B16.5 C150 Drilling
- AS2129 TABLE D AND AS4087 PN 16 - Full Pressure
- d20-1000

- Only for PE to PE connections - suitable for SDR 11 and SDR 17 Stub Flange Adaptors
- Profiled, aramid, PTFE, metallic / semi-metallic upon request

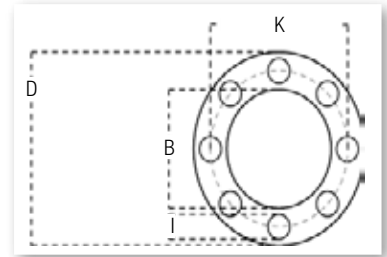

State specification details when ordering

*B (mm) - may vary depending upon specification

EDPM - WATER Code	NBR - GAS Code	Pipe Diameter	DN	D	B*	K	I	Number of Holes	Delivery Code
		mm	mm	mm	mm	mm	mm		
EDPM NBR ASTM B16.5 C150 Drilling									
GFF020X015AW	GFF020X015AG	20	15	89	22	60.5	16	4	C
GFF025X020AW	GFF025X020AG	25	20	95	27	70	16	4	C
GFF032X025AW	GFF032X025AG	32	25	108	34	79.5	16	4	C
GFF040X032AW	GFF040X032AG	40	32	117	43	89	16	4	C
GFF050X040AW	GFF050X040AG	50	40	127	49	98.5	16	4	C
GFF063X050AW	GFF063X050AG	63	50	152	55	120.5	20	4	C
GFF075X065AW	GFF075X065AG	75	65	178	68	139.5	20	4	C
GFF090X080AW	GFF090X080AG	90	80	191	82	152	20	4	C
GFF110X100AW	GFF110X100AG	110	100	229	96	190.5	20	8	C
GFF125X125AW	GFF125X125AG	125	125	254	112	216	22	8	C
GFF140X125AW	GFF140X125AG	140	125	254	126	216	22	8	C
GFF160X150AW	GFF160X150AG	160	150	279	150	241	22	8	C
GFF180X150AW	GFF180X150AG	180	150	279	156	241	22	8	C
GFF200X200AW	GFF200X200AG	200	200	343	178	298.5	22	8	C
GFF225X200AW	GFF225X200AG	225	200	343	198	298.5	22	8	C
GFF250X250AW	GFF250X250AG	250	250	406	216	362	26	12	C
GFF280X250AW	GFF280X250AG	280	250	406	248	362	26	12	C
GFF315X300AW	GFF315X300AG	315	300	483	268	432	26	12	C
GFF355X350AW	GFF355X350AG	355	350	533	304	476	30	12	C
GFF400X400AW	GFF400X400AG	400	400	597	352	540	30	16	C
GFF450X450AW	GFF450X450AG	450	450	635	398	578	33	16	C
GFF500X500AW	GFF500X500AG	500	500	699	440	635	33	20	C
GFF560X600AW	GFF560X600AG	560	600	750	492	692	36	20	C
GFF630X600AW	GFF630X600AG	630	600	813	540	750	36	20	C
EDPM NBR AS2129 Table D/E/AS4087 PN16 - Full Pressure									
GFF063X050DE16W	GFF063X050DE16G	63	50	150	55	114	18	4	C
GFF075X065DE16W	GFF075X065DE16G	75	65	165	68	127	18	4	C
GFF090X080DE16W	GFF090X080DE16G	90	80	184	82	146	18	4	C
GFF110X100D16W	GFF110X100D16G	110	100	215	96	178	18	4	C
GFF125X100D16W	GFF125X100D16G	125	100	215	112	178	18	4	C
GFF125X125DE16W	GFF125X125DE16G	125	125	254	112	210	18	8	C
GFF140X125DE16W	GFF140X125DE16G	140	125	254	126	210	18	8	C
GFF160X150D16W	GFF160X150D16G	160	150	279	150	235	18	8	C
GFF180X150D16W	GFF180X150D16G	180	150	279	156	235	18	8	C
GFF200X200D16W	GFF200X200D16G	200	200	335	178	292	18	8	C
GFF225X200D16W	GFF225X200D16G	225	200	335	198	292	18	8	C
GFF250X250D16W	GFF250X250D16G	250	250	405	216	356	22	8	C
GFF280X250D16W	GFF280X250D16G	280	250	405	248	356	22	8	C
GFF315X300D16W	GFF315X300D16G	315	300	455	268	406	22	12	C
GFF355X350DE16W	GFF355X350DE16G	355	350	525	304	470	26	12	C
GFF400X400DE16W	GFF400X400DE16G	400	400	578	352	521	26	12	C
GFF450X450D16W	GFF450X450D16G	450	450	640	398	584	26	12	C
GFF500X500DE16W	GFF500X500DE16G	500	500	705	440	641	26	16	C
GFF630X600D16W	GFF630X600D16G	630	600	825	540	756	30	16	C
GFF710X700D16W	GFF710X700D16G	710	700	910	upon request	845	30	20	C
GFF800X800D16W	GFF800X800D16G	800	800	1060	upon request	984	36	20	C
GFF900X900D16W	GFF900X900D16G	900	900	1175	upon request	1092	36	24	C
GFF1000D16W	GFF1000D16G	1000	1000	1255	upon request	1175	36	24	C

Full Face Gaskets - EDPM / NBR Duo - Continued



- EDPM - Water
- NBR - Gas
- AS2129 TABLE E
- AS2129 TABLE D AND AS4087 PN 10 ONLY
- d110-1000

- Only for PE to PE connections - suitable for SDR 11 and SDR 17 Stub Flange Adaptors
- Profiled, aramid, PTFE, metallic / semi-metallic upon request

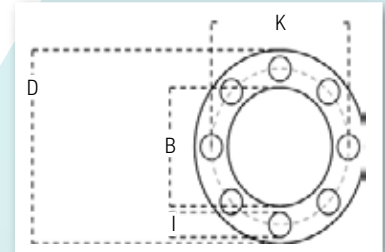

State specification details when ordering

*B (mm) - may vary depending upon specification

EDPM - WATER Code	NBR - GAS Code	Pipe Diameter	DN	D	B*	K	I	Number of Holes	Delivery Code
		mm	mm	mm	mm	mm	mm		
EDPM NBR AS2129 Table E									
GFF110X100E16W	GFF110X100E16G	110	100	215	96	178	18	8	C
GFF125X100E16W	GFF125X100E16G	125	100	215	112	178	18	8	C
GFF160X150E16W	GFF160X150E16G	160	150	279	150	235	22	8	C
GFF180X150E16W	GFF180X150E16G	180	150	279	156	235	22	8	C
GFF200X200E16W	GFF200X200E16G	200	200	335	178	292	22	8	C
GFF225X200E16W	GFF225X200E16G	225	200	335	198	292	22	8	C
GFF250X250E16W	GFF250X250E16G	250	250	405	216	356	22	12	C
GFF280X250E16W	GFF280X250E16G	280	250	405	248	356	22	12	C
GFF315X300E16W	GFF315X300E16G	315	300	455	268	406	26	12	C
GFF450X450E16W	GFF450X450E16G	450	450	640	398	584	26	16	C
GFF560X560E16W	GFF560X560E16G	560	560	760	492	699	30	16	C
GFF630X600E16W	GFF630X600E16G	630	600	825	540	756	33	16	C
GFF710X700E16W	GFF710X700E16G	710	700	910	upon request	845	33	20	C
GFF800X800E16W	GFF800X800E16G	800	800	1060	upon request	984	36	20	C
GFF900X900E16W	GFF900X900E16G	900	900	1175	upon request	1092	36	24	C
GFF1000E16W	GFF1000E16G	1000	1000	1255	upon request	1175	39	24	C
EDPM NBR AS2129 Table D/AS4087 PN10									
GFF315X300D10W	GFF315X300D10G	315	300	455	268	406	22	12	C
GFF355X350D10W	GFF355X350D10G	355	350	525	304	470	26	12	C
GFF400X400D10W	GFF400X400D10G	400	400	578	352	521	26	12	C
GFF450X450D10W	GFF450X450D10G	450	450	640	398	584	26	12	C
GFF500X500D10W	GFF500X500D10G	500	500	705	440	641	26	16	C
GFF560X560D10W	GFF560X560D10G	560	560	760	492	699	30	16	C
GFF630X600D10W	GFF630X600D10G	630	600	825	540	756	30	16	C
GFF710X700D10W	GFF710X700D10G	710	700	910	upon request	845	30	20	C
GFF800X800D10W	GFF800X800D10G	800	800	1060	upon request	984	36	20	C
GFF900X900D10W	GFF900X900D10G	900	900	1175	upon request	1092	36	24	C
GFF1000D10W	GFF1000D10G	1000	1000	1255	upon request	1175	36	24	C

TRANSITION FITTINGS

FOR GAS AND WATER



Transition fittings are a quick and easy way to connect various types of metallic pipes to PE pipe systems, using either a traditional flange, threaded or a modern SupaGrip™ fitting.

All fittings supplied by Fusion are manufactured according to the appropriate industry standards with the mechanical joint between the metal and PE fully end loading.

There is a varied range of fittings available under the title transition fittings including valves, elbows, and straight transitions from d25 to 250 PE in both PE80 and PE100 materials.

Electrofusion coupling for quick and easy installation onto existing PE pipe

Mechanical coupler is **designed to be universal fit**

Lifting eye on sizes with a weight exceeding 10 kilos (DN 100-300)



Assembled **male or female transition adaptor** with coupler allows metric to threaded imperial connections.



Patented SupaGrip™ sealing support system with flexible bracket



Purpose designed positioning plate secures the fitting to the concrete pad to ensure that the correct height is guaranteed.

PE ends enable the fittings to be directly electrofused to the existing pipeline **saving time and money**



3

4 bolts for **quick and easy installation**

4



Split flange ring for ease of installation and **flexible hole alignment**

1. Fusion Male transition coupler for GAS and WATER

Suitable for electrofusion welding on site but also available separately for manifold applications or pre fabrication. Other materials and threads are available upon request depending on specialist applications. A simple but effective solution for house connections, used by many operators internationally.

2. Supa Maxi™ range of universal tensile for WATER.

The patented SupaGrip™ sealing support system with flexible bracket ensures full support of the gasket and full tensile strength on all pipe types up to PN16. Supa Maxi™ couplings are very easy to mount with the possibility of $\pm 4^\circ$ angular deflection, the permanent protection caps, the lifting eye and that they are tightened from the sleeve side with no need for re-tightening the bolts.

3. Donkin Mechanical Coupler for GAS

The Series 604 mechanical coupler with PE tail has been designed as a transition fitting to join metallic and PE gas pipes. The mechanical coupler is designed to be universal in most diameters whilst the PE end is available in SDR17 PE80 pipe suitable for the low and medium pressure network.

4. Meter Module Riser Fittings for GAS

The Series 218 Meter Module Riser Fittings are transition fittings designed to connect the underground PE pipework to the Emergency Control Valve at the inlet of a Meter Module. They can also be used on the outlet pipework to transition back to PE from the steel. Small diameters are available with threaded ends and the larger sizes with PN16 flanges for easy connection.

Supa Maxi™ Transition Coupling



- PN16
- Ductile Iron
- EN 14525
- DN50-300

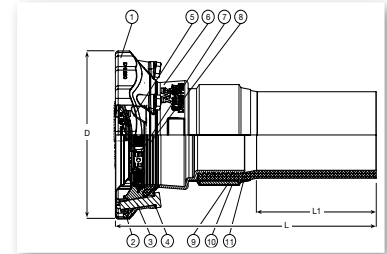

Code	DN/Ø	T	PN	D	L	L1	Weight	Delivery Code
	mm	mm	Bar	mm	mm	mm	Kg	
635-071-00-266	50 - 63	48 - 71	10	200	540	300	4.5	C
635-091-00-266	65 - 75	69 - 91	10	226	551	250	5.6	C
635-105-00-266	80 - 90	82 - 106	10	235	533	250	7.5	C
635-106-00-266	80 - 110	82 - 106	10	235	543	255	6	C
635-133-00-266	100 - 110	104 - 133	10	268	547	250	10	C
635-161-00-266	125 - 160	132 - 161	10	285	625	325	16	C
635-188-00-266	150 - 160	159 - 188	10	340	644	325	18	C
635-227-00-266	200 - 200	193 - 227	10	389	648	255	27	C
635-257-00-266	225 - 250	224 - 257	10	437	788	340	48	C
635-301-00-266	250 - 250	266 - 301	10	476	784	340	49	C
635-356-00-266	300 - 315	314 - 356	10	545	784	355	64	C
635-071-00-166	50 - 63	48 - 71	16	200	540	300	4.5	C
635-091-00-166	65 - 75	69 - 91	16	226	551	250	5.6	C
635-105-00-166	80 - 90	82 - 106	16	235	533	250	7.5	C
635-106-00-166	80 - 110	82 - 106	16	235	543	255	6	C
635-133-00-166	100 - 110	104 - 133	16	268	547	250	10	C
635-161-00-166	125 - 160	132 - 161	16	285	625	325	16	C
635-188-00-166	150 - 160	159 - 188	16	340	644	325	18	C
635-227-00-166	200 - 200	193 - 227	16	389	648	255	27	C
635-257-00-166	225 - 250	224 - 257	16	437	788	340	48	C
635-301-00-166	250 - 250	266 - 301	16	476	784	340	49	C
635-356-00-166	300 - 315	314 - 356	16	545	784	355	64	C



Male Transition Coupler

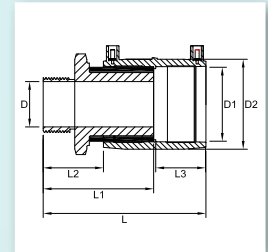

- PE100
- Water PN16
- Gas 10 Bar
- d25x¾" - 63x2"

4mm Pin Fitting Code	4.7mm Pin Fitting Code	Fitting Size	L	L1	L2	L3	D	D1	D2	Fusion Time	Cooling Time	Weight	Box Quantity	Box Size (W X L X D)	Delivery Code
		mm	mm	mm	mm	mm	mm	mm	mm	mm	secs	mins		Kg	
ZCBKHFM25X0.8	ZCBKHA25X0.8	25 x ¾"	138.5	99	61.5	37.5	¾"	25	33.5	30	3	0.17	50	295 X 485 X 199	A
ZCBKHFM32X0.5	ZCBKHA32X0.5	32 x ½"	170.0	100	62.5	37.5	½"	32	43.0	45	3	0.38	50	295 X 485 X 199	A
ZCBKHFM32X0.8	ZCBKHA32X0.8	32 x ¾"	138.5	99	61.5	37.0	¾"	32	34.0	30	3	0.18	50	295 X 485 X 199	A
ZCBKHFM32X1	ZCBKHA32X1	32 x 1"	149.5	110	72.5	38	1	32	43.0	45	3	0.24	40	295 X 485 X 199	A
ZCBKHFM32X1.3	ZCBKHA32X1.3	32 x 1¼"	166.0	121	75.0	43	1¼"	32	44.0	50	5	0.48	30	295 X 485 X 199	A
ZCBKHFM32X1.5	ZCBKHA32X1.5	32 x 1½"	165.5	134	74.5	41	1½"	32	44.0	60	5	0.49	24	295 X 485 X 199	A
ZCBKHFM40X1	ZCBKHA40X1	40 x 1"	155.0	110	64.0	43	1	40	44.0	50	5	0.26	40	295 X 485 X 199	A
ZCBKHFM40X1.3	ZCBKHA40X1.3	40 x 1¼"	167.0	121	77.0	44	1¼"	40	51.5	40	5	0.36	25	295 X 485 X 199	A
ZCBKHFM40X1.5	ZCBKHA40X1.5	40 x 1½"	179.0	134	88.0	43	1½"	40	52.0	60	5	0.48	24	295 X 485 X 199	A
ZCBKHFM50X1	ZCBKHA50X1	50 x 1"	160.0	110	69.0	41	1	50	44.0	60	5	0.28	30	295 X 485 X 199	A
ZCBKHFM50X1.3	ZCBKHA50X1.3	50 x 1¼"	158.0	121	67.0	43	1¼"	50	44.0	60	5	0.50	30	295 X 485 X 199	A
ZCBKHFM50X1.5	ZCBKHA50X1.5	50 x 1½"	181.0	134	90.0	44	1 ½"	50	61.5	90	5	0.47	18	295 X 485 X 199	A
ZCBKHFM50X2	ZCBKHA50X2	50 x 2"	200.0	150	98.0	48	2	50	62.0	120	10	0.71	12	295 X 485 X 199	A
ZCBKHFM63X1.3	ZCBKHA63X1.3	63 x 1¼"	171.0	121	69.0	45	1¼"	63	78.0	70	5	0.42	15	295 X 485 X 199	A
ZCBKHFM63X1.5	ZCBKHA63X1.5	63 x 1½"	184.0	134	82.0	48	1½"	63	78.0	120	10	0.53	15	295 X 485 X 199	A
ZCBKHFM63X2	ZCBKHA63X2	63 x 2"	203.0	150	101.0	49	2	63	77.0	35	3	0.71	12	295 X 485 X 199	A

Female Transition Coupler

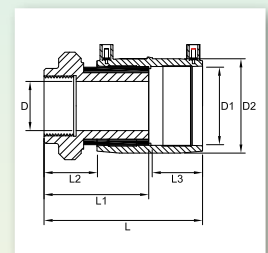

- PE100
- Water PN16
- Gas 10 Bar
- d25x¾" - 63x2"

4mm Pin Fitting Code	4.7mm Pin Fitting Code	Fitting Size	L	L1	L2	L3	D	D1	D2	Fusion Time	Cooling Time	Weight	Box Quantity	Box Size (W X L X D)	Delivery Code
		mm	mm	mm	mm	mm	mm	mm	mm	mm	secs	mins		Kg	
XCBKHFM25X0.8	XCBKHA25X0.8	25 x ¾"	130.5	91	53.5	37.5	¾"	25	33.5	30	5	0.17	50	295 X 485 X 199	A
XCBKHFM32X0.8	XCBKHA32X0.8	32 x ½"	131.0	91	54.0	37.0	¾"	32	34.0	30	3	0.30	50	295 X 485 X 199	A
XCBKHFM32X1	XCBKHA32X1	32 x 1"	139.5	100	62.5	38	1	32	43.0	45	3	0.26	40	295 X 485 X 199	A
XCBKHFM40X1	XCBKHA40X1	40 x 1"	148.0	100	57.0	43	1	40	44.0	50	5	0.28	40	295 X 485 X 199	A
XCBKHFM40X1.3	XCBKHA40X1.3	40 x 1¼"	155.0	109	65.0	44	1¼"	40	51.5	40	5	0.39	25	295 X 485 X 199	A
XCBKHFM40X1.5	XCBKHA40X1.5	40 x 1½"	172.0	124	81.0	43	1½"	40	52.0	60	5	0.53	24	295 X 485 X 199	A
XCBKHFM50X1.3	XCBKHA50X1.3	50 x 1¼"	157.0	109	66.0	43	1¼"	50	44.0	60	5	0.40	25	295 X 485 X 199	A
XCBKHFM50X1.5	XCBKHA50X1.5	50 x 1½"	171.0	124	80.0	44	1 ½"	50	61.5	90	5	0.53	18	295 X 485 X 199	A
XCBKHFM50X2	XCBKHA50X2	50 x 2"	195.0	141	93.0	48	2	50	62.0	120	10	0.78	15	295 X 485 X 199	A
XCBKHFM63X1	XCBKHA63X1	63 x 1"	150.0	100	48.0	52	1	63	78.0	90	5	0.59	20	295 X 485 X 199	A
XCBKHFM63X1.5	XCBKHA63X1.5	63 x 1½"	178.0	124	76.0	48	1½"	63	78.0	120	10	0.58	15	295 X 485 X 199	A
XCBKHFM63X2	XCBKHA63X2	63 x 2"	194.0	141	92.0	49	2	63	77.0	35	3	0.80	15	295 X 485 X 199	A

Male Transition 90° Elbow

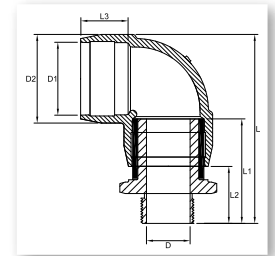

- PE100
- Water PN16
- Gas 10 Bar
- d25x¾" - 63x2"

4mm Pin Fitting Code	4.7mm Pin Fitting Code	Fitting Size	L	L1	L2	L3	D	D1	D2	Fusion Time	Cooling Time	Weight	Box Quantity	Box Size (W X L X D)	Delivery Code
														mm	
ZEBKHF25X900.8	ZEBKHA25X900.8	25 x ¾"	131.0	99	55.0	44.0	¾	25	35.0	30	3	0.19	30	295 X 485 X 199	A
ZEBKHF32X901	ZEBKHA32X901	32 x 1"	154.0	110	70.0	40	1	32	44.0	60	5	0.28	36	295 X 485 X 199	A
ZEBKHF40X901.3	ZEBKHA40X901.3	40 x 1¼"	170.0	121	79.0	42	1¼	40	52.0	50	5	0.52	30	295 X 485 X 199	A
ZEBKHF50X901.5	ZEBKHA50X901.5	50 x 1½"	192.0	124	79.5	44.5	1½	50	63.0	90	5	0.57	30	295 X 485 X 199	A
ZEBKHF63X902	ZEBKHA63X902	63 x 2"	223.0	150	100.0	50	2	63	81.0	35	5	0.87	5	295 X 485 X 199	A

Female Transition 90° Elbow

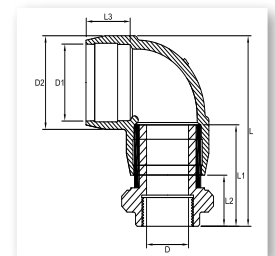

- PE100
- Water PN16
- Gas 10 Bar
- d25x¾" - 63x2"

4mm Pin Fitting Code	4.7mm Pin Fitting Code	Fitting Size	L	L1	L2	L3	D	D1	D2	Fusion Time	Cooling Time	Weight	Box Quantity	Box Size (W X L X D)	Delivery Code
														mm	
XEBKHF25X900.8	XEBKHA25X900.8	25 x ¾"	123.0	91	47.0	44.0	¾	25	35.0	30	3	0.31	40	295 X 485 X 199	A
XEBKHF32X901	XEBKHA32X901	32 x 1"	144.0	100	60.0	40	1	32	44.0	60	5	0.55	36	295 X 485 X 199	A
XEBKHF40X901.3	XEBKHA40X901.3	40 x 1¼"	158.0	109	67.0	42	1¼	40	52.0	50	5	0.52	30	295 X 485 X 199	A
XEBKHF50X901.5	XEBKHA50X901.5	50 x 1½"	182.0	124	79.0	45	1½	50	63.0	90	5	0.57	30	295 X 485 X 199	A
XEBKHF63X902	XEBKHA63X902	63 x 2"	214.0	141	91.0	50	2	63	81.0	35	5	0.81	10	295 X 485 X 199	A



Male Transition 45° Elbow



- PE100
- Water PN16
- Gas 10 Bar
- d32x1" - 63x2"

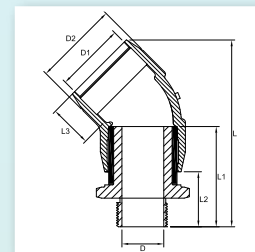

4mm Pin Fitting Code	4.7mm Pin Fitting Code	Fitting Size	L	L1	L2	L3	D	D1	D2	Fusion Time	Cooling Time	Weight	Box Quantity	Box Size (W X L X D)	Delivery Code
			mm	mm	mm	mm	mm	mm	mm	mm	secs	mins		Kg	
ZEBKHFM32X451	ZEBKHA32X451	32 x 1"	160.0	100	61.0	39.0	1	32	44.0	45	5	0.26	30	295 X 485 X 199	A
ZEBKHFM50X451.5	ZEBKHA50X451.5	50 x 1½"	203.5	124	79.5	44.5	1½	50	64.0	90	5	0.54	20	295 X 485 X 199	A
ZEBKHFM63X452	ZEBKHA63X452	63 x 2"	228.0	141	91.0	50	2	63	78.5	35	5	0.78	12	295 X 485 X 199	A

Female Transition 45° Elbow



- PE100
- Water PN16
- Gas 10 Bar
- d32x1" - 63x2"

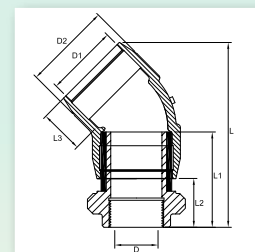

4mm Pin Fitting Code	4.7mm Pin Fitting Code	Fitting Size	L	L1	L2	L3	D	D1	D2	Fusion Time	Cooling Time	Weight	Box Quantity	Box Size (W X L X D)	Delivery Code
			mm	mm	mm	mm	mm	mm	mm	mm	secs	mins		Kg	
XEBKHFM32X451	XEBKHA32X451	32 x 1"	160.0	100	61.0	39.0	1	32	44.0	45	5	0.55	30	295 X 485 X 199	A
XEBKHFM40X451.3	XEBKHA40X451.3	40 x 1¼"	175.5	109	67.5	41.5	1¼	40	53.00	50	5	0.43	30	295 X 485 X 199	A
XEBKHFM50X451.5	XEBKHA50X451.5	50 x 1½"	203.5	124	79.5	44.5	1½	50	64.0	90	5	0.34	15	295 X 485 X 199	A
XEBKHFM63X452	XEBKHA63X452	63 x 2"	228.0	141	91.0	50	2	63	78.5	35	5	0.78	12	295 X 485 X 199	A

Transition Adaptor - Brass (not coated) - Male

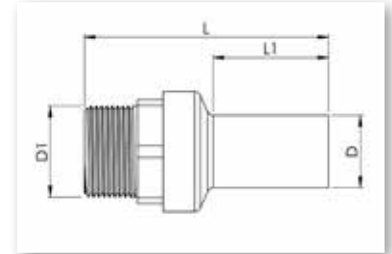

- PE100
- SDR11
- Water PN16
- Gas 10 Bar
- d20x1/2" - 125x4"

Code	D-D1	L	L1	Weight	Box Quantity	Delivery Code
	mm	mm	mm	Kg		
SDR11 NBR-Duo Water PN16 Gas PN6 EN1092						
AX67100	20 X 1/2"	92	38	0.110	70	A
AX67122	20 x 3/4"	92	38	0.110	70	A
AX67101	25 x 3/4"	99	40	0.120	50	A
AX67102	32 x 1"	110	44	0.180	30	A
AX67103	40 x 1 1/4"	121	49	0.270	15	A
AX67104	50 x 1 1/2"	134	54	0.370	10	A
AX67105	63 x 2"	150	63	0.590	6	A
AX67106	75 x 2 1/2"	165	73	0.890	15	A
AX67107	90 x 3"	181	82	1.140	10	A
AX67108	110 x 4"	194	84	1.860	6	A
AX67109	125 x 4"	202	92	3.000	4	A

Transition Adaptor - Brass (not coated) - Female

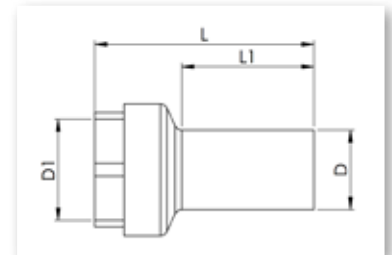

- PE100
- SDR11
- Water PN16
- Gas 10 Bar
- d20x1/2" - 125x4"

Code	D-D1	L	L1	Weight	Box Quantity	Delivery Code
	mm	mm	mm	Kg		
PE100 SDR11 Water PN16 Gas 10 Bar Female						
AX67110	20 X 1/2"	82	38	0.120	70	A
AX67123	20 x 3/4"	82	38	0.120	70	A
AX67111	25 x 3/4"	91	40	0.150	50	A
AX67112	32 x 1"	100	44	0.200	30	A
AX67113	40 x 1 1/4"	109	49	0.320	15	A
AX67114	50 x 1 1/2"	124	54	0.380	10	A
AX67115	63 x 2"	141	63	0.600	6	A
AX67116	75 x 2 1/2"	163	73	0.900	15	A
AX67117	90 x 3"	181	82	1.150	10	A
AX67118	110 x 4"	190	84	1.870	6	A
AX67119	125 x 4"	165	91	1.920	6	A



Transition Adaptor - Brass DZR - Male

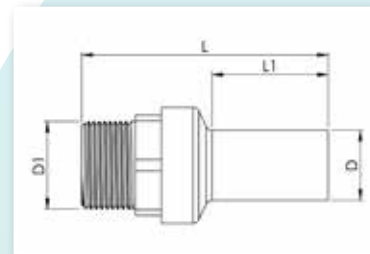

- PE100
- SDR11
- Water PN16
- Gas 10 Bar
- d20x1/2" - 125x4"

Code	D-D1	L	L1	Weight	Box Quantity	Delivery Code
	mm	mm	mm	Kg		
PE100 SDR11 Water PN16 Gas 10 Bar Male						
AX67141	20 X 1/2"	92	38	0.110	70	A
AX67142	20 x 3/4"	92	38	0.110	70	A
AX67143	25 x 3/4"	99	40	0.120	50	A
AX67144	32 x 1"	110	44	0.180	30	A
AX67145	40 x 1 1/4"	121	49	0.270	15	A
AX67146	50 x 1 1/2"	134	54	0.370	10	A
AX67147	63 x 2"	150	63	0.590	6	A
AX67148	75 x 2 1/2"	165	73	0.890	15	A
AX67149	90 x 3"	181	82	1.140	10	A
AX67150	110 x 4"	194	84	1.860	6	A
AX67151	125 x 4"	202	92	3.000	4	A

Transition Adaptor - Brass DZR - Female

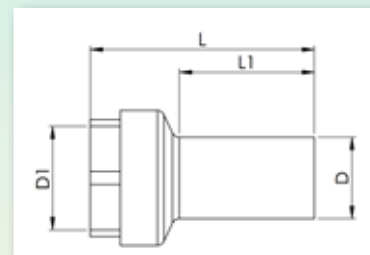

- PE100
- SDR11
- Water PN16
- Gas 10 Bar
- d20x1/2" - 125x4"

Code	D-D1	L	L1	Weight	Box Quantity	Delivery Code
	mm	mm	mm	Kg		
PE100 SDR11 Water PN16 Gas 10 Bar Female						
AX67152	20 X 1/2"	82	38	0.120	70	A
AX67153	20 x 3/4"	82	38	0.120	70	A
AX67154	25 x 3/4"	91	40	0.150	50	A
AX67155	32 x 1"	100	44	0.200	30	A
AX67156	40 x 1 1/4"	109	49	0.320	15	A
AX67157	50 x 1 1/2"	124	54	0.380	10	A
AX67158	63 x 2"	141	63	0.600	6	A
AX67159	75 x 2 1/2"	163	73	0.900	15	A
AX67160	90 x 3"	181	82	1.150	10	A
AX67161	110 x 4"	190	84	1.870	6	A
AX67162	125 x 4"	165	91	1.920	6	A



Transition Adaptor - Stainless Steel - Male

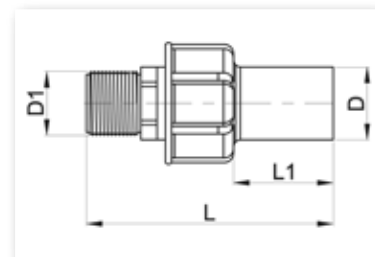

- PE100
- SDR11
- Water PN16
- Gas 10 Bar
- d20x1/2" - 63x2"

Code	D-D1	L	L1	Weight	Box Quantity	Delivery Code
	mm	mm	mm	Kg		
PE100 SDR11 Water PN16 Gas 10 Bar Male						
AX67131	20 X 1/2"	85	38	0.100	70	A
AX67132	25 x 3/4"	95	40	0.110	50	A
AX67133	32 x 1"	105	44	0.170	30	A
AX67134	40 x 1 1/4"	115	49	0.250	15	A
AX67135	50 x 1 1/2"	130	54	0.340	10	A
AX67136	63 x 2"	148	63	0.530	6	A

Transition Adaptor - Stainless Steel - Female

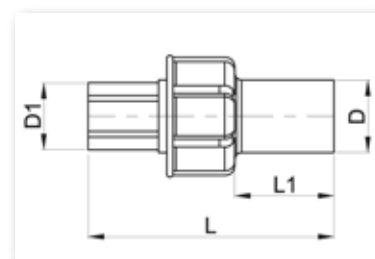

- PE100
- SDR11
- Water PN16
- Gas 10 Bar
- d20x1/2" - 63x2"

Code	D-D1	L	L1	Weight	Box Quantity	Delivery Code
	mm	mm	mm	Kg		
PE100 SDR11 Water PN16 Gas 10 Bar Female						
AX67120	20 X 1/2"	82	38	0.100	70	A
AX67137	25 x 3/4"	91	40	0.110	50	A
AX67121	32 x 1"	100	44	0.170	30	A
AX67138	40 x 1 1/4"	109	49	0.250	15	A
AX67139	50 x 1 1/2"	124	54	0.340	10	A
AX67140	63 x 2"	141	63	0.530	6	A



PE - Steel Transition Piece (Weldable end)

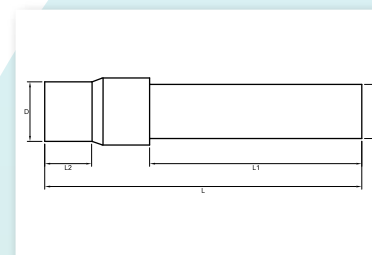

- PE100
- SDR 11 - Water PN16 / Gas 10 Bar
- SDR 17 - Water PN10 / Gas upon request
- d20x¾" - 400x16"

Code	D-d mm	L mm	L1 mm	L2 mm	Weight Kg	Box Quantity	Delivery Code
PE100 SDR11 Water PN16 Gas 10 Bar							
PESBKH25X0.75W	25 x ¾"	381	194	126	0.620	1	C
PESBKH32X1W	32 x 1"	390	194	135	0.880	1	C
PESBKH40X1.3W	40 x 1¼"	407	193	151	1.150	1	C
PESBKH50X1.5W	50 x 1½"	426	190	169	1.380	1	C
PESBKH63X2W	63 x 2"	448	190	190	1.800	1	C
PESBKH75X2.5W	75 x 2½"	545	130	310	2.680	1	C
PESBKH90X3W	90 x 3"	560	150	310	3.500	1	C
PESBKH110X4W	110 x 4"	580	160	310	6.350	1	C
PESBKH125X4W	125 x 4"	580	160	310	6.550	1	C
PESBKH140X5W	140 x 5"	580	160	310	7.200	1	C
PESBKH160X6W	160 x 6"	600	160	310	10.500	1	C
PESBKH180X6W	180 x 6"	600	160	310	10.700	1	C
PESBKH200X8W	200 x 8"	620	150	310	16.500	1	C
PESBKH225X8W	225 x 8"	600	130	310	18.500	1	C
PESBKH250X10W	250 x 10"	630	180	300	24.100	1	C
PESBKH280X10W	280 x 10"	-	-	-	29.800	1	C
PESBKH315X12W	315 x 12"	780	180	315	42.420	9	C
PE100 SDR17 Water PN10 Gas upon request							
PESBKHV200X8W	200 x 8"	750	114	315	21.780	1	C
PESBKHV225X8W	225 x 8"	620	132	315	23.540	19	C
PESBKHV250X10W	250 x 10"	920	130	315	44.060	1	C
PESBKHV315X12W	315 x 12"	-	-	-	50.500	1	C
PESBKHV355X14W	355 x 14"	-	-	-	51.000	1	C
PESBKHV400X16W	400 x 16"	-	-	-	63.000	1	C

PE - Steel Transition Piece (Threaded End)

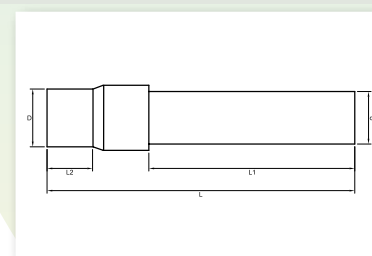

- PE100
- SDR11
- Water PN16
- Gas 10 Bar
- d25x¾" - 125x4"

Code	D-D1 mm	L mm	L1 mm	L2 mm	Weight Kg	Box Quantity	Delivery Code
PE100 SDR11 Water PN16 Gas 10 Bar							
PESBKH25X0.75T	25 x ¾"	432	67	300	0.640	35	C
PESBKH32X1T	32 x 1"	442	75	300	0.880	20	C
PESBKH40X1.3T	40 x 1¼"	446	79	300	1.180	12	C
PESBKH50X1.5T	50 x 1½"	471	83	300	1.490	9	C
PESBKH63X2T	63 x 2"	483	90	300	2.080	6	C
PESBKH75X2.5T	75 x 2½"	522	105	300	3.010	4	C
PESBKH90X3T	90 x 3"	544	121	300	3.940	2	C
PESBKH110X4T	110 x 4"	556	123	300	5.910	5	C
PESBKH125X4T	125 x 4"	590	135	300	6.750	4	C



PE - Steel Curved Transition Piece (Weldable End)



- PE100
- SDR11
- Water PN16
- Gas 10 Bar
- d25 x ¾" - 63 x 2"

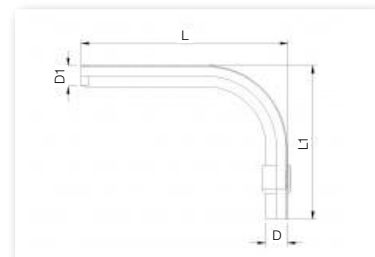

Code	D-D1 mm	L mm	L1 mm	Weight Kg	Box Quantity	Delivery Code
PE100 SDR11 Water PN16 Gas 10 Bar						
PESBKH25X0.75WC	25 x ¾"	800	-	1.730	150	C
PESBKH32X1WC	32 x 1"	825	-	2.790	90	C
PESBKH40X1.3WC	40 x 1¼"	800	-	3.600	50	C
PESBKH50X1.5WC	50 x 1½"	800	-	4.460	50	C
PESBKH63X2WC	63 x 2"	825	-	6.560	30	C

PE - Steel Curved Transition Piece (Threaded End)



- PE100
- SDR11
- Water PN16
- Gas 10 Bar
- d25 x ¾" - 63 x 2"

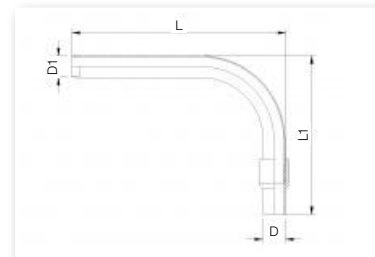

Code	D-D1 mm	L mm	L1 mm	Weight Kg	Box Quantity	Delivery Code
PE100 SDR11 Water PN16 Gas 10 Bar						
PESBKH25X0.75TC	25 x ¾"	800	-	1.730	150	C
PESBKH32X1TC	32 x 1"	825	-	2.790	90	C
PESBKH40X1.3TC	40 x 1¼"	800	-	3.600	50	C
PESBKH50X1.5TC	50 x 1½"	800	-	4.460	50	C
PESBKH63X2TC	63 x 2"	825	-	6.560	30	C

Mains to Meter Factory Entry Elbow



- Series 217/31-001, 002
- PN4
- GIS/PL3
- PE x Screwed 001
- PE x Pipe End 002
- d40x1½" - 180x6"

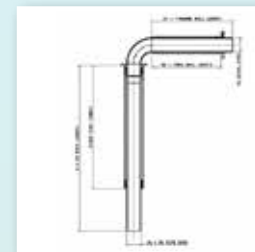

Code	PE	SDR	B1 (Through Wall)	C (PE80 Length)	D (GRP Length)	E (Steel Pipe)	B2 (Through Wall) Pe Pipe DN	Weight	Delivery Code
	mm		mm	mm	mm	mm	mm	Kg	
217040134510090	40	11	345	1	0.9	48.1	63	6	C
217040150010090	40	11	500	1	0.9	48.1	63	7	C
217063215010090	63	11	150	1	0.9	60.3	75	7	C
217063234510090	63	11	345	1	0.9	60.3	75	9	C
217063250010090	63	11	500	1	0.9	60.3	75	10	C
217063250020090	63	11	500	2	1.9	60.3	75	13	C
217063261010090	63	11	610	1	0.9	60.3	75	11	C
217090334510075	90	11	345	1	0.75	88.9	110	14	C
217090350020150	90	11	500	2	1.5	88.9	110	21	C
217090361020150	90	11	610	2	1.5	88.9	110	22	C
217090361010075	90	11	610	1	0.75	88.9	110	19	C
217125434510075	125	11	345	1	0.75	114.3	125	24	C
217125461010075	125	11	610	1	0.75	114.3	125	30	C
217125461020150	125	11	610	2	1.5	114.3	125	38.5	C
2171806345100752	180	17	345	1	0.75	168.3	200	35	C
2171806610100752	180	17	610	1	0.75	168.3	200	42.5	C
2171806610201502	180	17	610	2	1.5	168.3	200	55	C

Mains to Meter Factory Entry Elbow with Split Flange Ring



- Series 217/31-003
- PN4
- GIS/PL3
- d90x3" - 180x6"

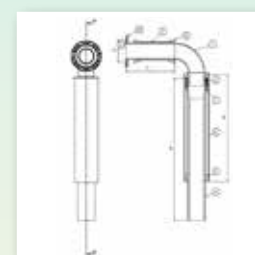

Code	PE	SDR	D	DN	A (GRP Length)	B (Length)	C (Through Wall Length)	Weight	Delivery Code
	mm		mm	mm	mm	mm	mm	Kg	
21709033451007501	90	11	132	80	750	1000	345	16	C
21709033452015001	90	11	132	80	1500	2000	345	16	C
21709035002015001	90	11	132	80	1500	2000	500	23	C
21709036101007501	90	17	132	80	750	1000	610	21	C
21709036102015001	90	11	132	80	1500	2000	610	24	C
21712543451007501	125	11	156	100	750	1000	345	26.5	C
21712546101007501	125	11	156	100	750	1000	610	32.5	C
21712546102015001	125	11	156	100	1500	2000	610	41	C
21718063451007521	180	17	211	150	750	1000	345	38.8	C
21718066101007521	180	17	211	150	750	1000	610	46	C
21718066102015021	180	17	211	150	1500	2000	610	59	C

Mains to Meter Building Entry Tee



- Series 219/31-001
- PN4
- GIS/PL3
- d20x¾" - 32x2"

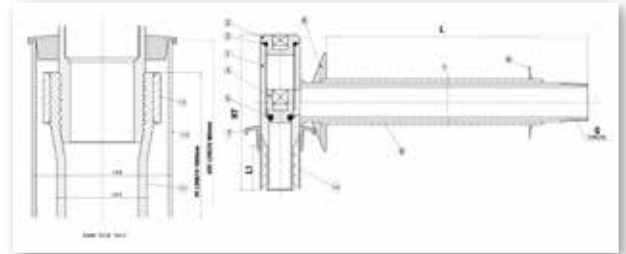

Code	DN	Through Wall	L	H7	L1	DØ	G Thread	PE Length	GRP Length	Weight	Delivery Code
	mm	mm	mm	mm	mm	mm	mm	mm	mm	Kg	
219-200-00	20	150	183	70	36	32	R¾	0	0	0.7	C
219-200-01	20	345	378	70	36	32	R¾	0	0	1.1	C
219-200-02	20	500	533	70	36	32	R¾	0	0	1.5	C
219-250-00	25	150	183	70	36	32	R¾	0	0	0.8	C
219-250-01	25	345	378	70	36	32	R¾	0	0	1.1	C
219-250-02	25	500	533	70	36	32	R¾	0	0	1.5	C
219-321-00	32	150	189	86	36	40	R1	0	0	1.2	C
219-321-01	32	345	384	86	36	40	R1	0	0	1.6	C
219-321-02	32	500	533	86	36	40	R1	0	0	2.1	C
219-321-03	32	610	649	86	36	40	R1	0	0	2.5	C
219-632-00-001	63	150	196	125	50	75	R2	1000	900	4	C
219-632-01-001	63	345	391	125	50	75	R2	1000	900	5.4	C
219-632-02-001	63	500	546	125	50	75	R2	1000	900	6.8	C
219-632-03-001	63	610	646	125	50	75	R2	1000	900	7.8	C

Mains to Meter Below Ground Entry Fitting



- PN4
- GIS/PL3
- PE x Screwed 001
- PE x Pipe End 002
- d25x¾" - 180x6"

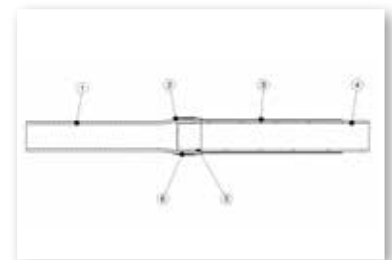

Code	Range	Spigot Type	Diameter of Through Wall PE	Weight	Delivery Code
	mm	mm		Kg	
21802500500501	25mm SDR11 x R¾"	0.5M x 0.5M PE80	40	5	C
21803210500501	32mm SDR11 x R1"	0.5M x 0.5M PE80	50	7	C
21806320500501	63mm SDR11 x R2"	0.5M x 0.5M PE80	75	13	C
218090305005	90mm SDR11 x 3" Plain	0.5M x 0.5M PE80	110	15	C
218090307512	90mm SDR11 x 3" Plain	0.75M x 1.25M PE 80	110	17	C
218125405010	125mm SDR11 x 4" Plain	0.5M X 1.0M PE80	125	24	C
218125407512	125mm SDR11 x 4" Plain	0.75M x 1.25M PE80	125	27	C
218125410015	125mm SDR11 x 4" Plain	1.0M x 1.5M PE80	125	30	C
2181806050102	180mm SDR17 x 6" Plain	0.5M x 1.0M PE80	200	TBA	C
2181806075122	180mm SDR17 x 6" Plain	0.75M x 1.25M PE80	200	TBA	C
2181806100152	180mm SDR17x 6" Plain	1.0M x 1.5M PE80	200	TBA	C
2181806120152	180mm SDR17x 6" Plain	1.2M x 1.5M PE80	200	TBA	C

Mains to Meter Below Ground Entry Fitting with Split Flange



- PN4
- GIS/PL3
- d90x3" - 180x6"

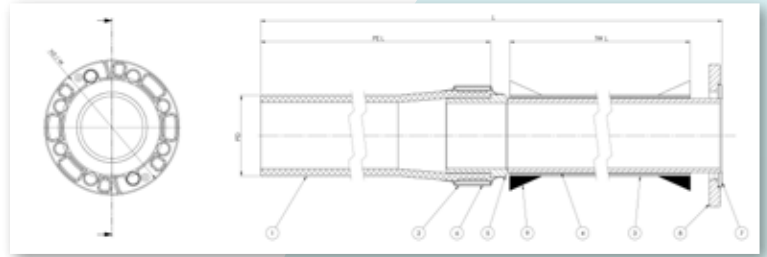

Code	Connection	H3	L	Pipe Diameter	PE Length	SDR	L Through Wall	W	Weight	Delivery Code
	mm	mm	mm	mm	mm	mm	mm	mm	Kg	
21809030500502	80	200	1027	90	500	11	450	200	10	C
21809030751002	80	200	1777	90	1000	11	700	200	11	C
21812540501002	100	220	1075	125	1000	11	450	220	19	C
21812540751202	100	220	2025	125	1250	11	700	220	20	C
21812541001502	100	220	2525	125	1500	11	950	220	20	C
21818060501022	150	285	1528	180	1000	17	450	285	42	C
21818060751222	150	285	2028	180	1250	17	700	285	42	C
21818061001522	150	285	2528	180	1500	17	650	285	42	C
21818061201522	150	285	2728	180	1500	17	1150	285	42	C

Mains to Meter Module Riser Fitting with Split Flange



- PN4
- GIS/PL3
- d25x¾" - 180x6"

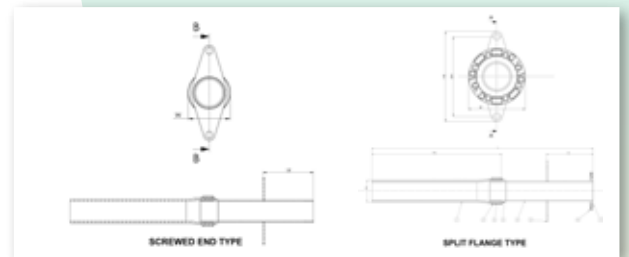

Code	Connection	Dh	H3	L	L6	Pipe Dia	PE Length	SDR	W	Weight	Delivery Code
	mm	mm	mm	mm	mm	mm	mm	mm	mm	Kg	
218-025-00-50070102	R¾	164	200	1276	170	25	750	11	46		C
218-032-10-50070102	R1	164	200	1276	170	32	750	11	52		C
218-063-20-50070202	50	214	250	1276	170	63	750	11	165		C
218-090-30-50070202	80	269	310	1277	295	90	750	11	200		C
218-090-40-50070202	100	309	350	1277	269	90	750	11	220		C
218-125-40-50070202	100	309	350	1275	269	125	750	11	220		C
218-125-60-50070202	150	409	450	1275	231	125	750	11	285		C
218-180-60-50072202	150	409	450	1278	231	180	750	17	285		C
218-180-80-50072202	200	509	550	1278	256	180	750	17	340		C
218-250-80-50072202	200	509	550	1288	256	250	750	17	340		C
218-250-90-50072202	250	609	650	1288	218	250	750	17	405		C

Service Isolation Valve - PE to PE



- PN4/7
- Ductile Iron Body
- Stainless Steel Ball
- GIS/V4
- GIS/PL3
- DN $\frac{3}{4}$ -2" / 25-63mm

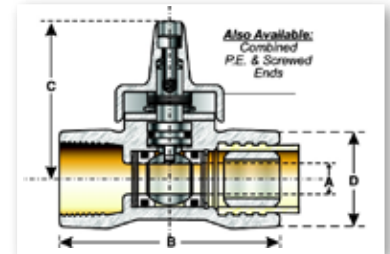

Code	DN mm	A mm	B mm	C mm	Weight Kg	Delivery Code
451025057213001	25	11.5	310	72	1	C
451032057213001	32	14.5	302	73	1.3	C
451063057213001	63	30	436	84	3.65	C

Service Isolation Valve - PE to SC



- PN4/7
- Ductile Iron Body
- Stainless Steel Ball
- GIS/V4
- GIS/PL3
- DN $\frac{3}{4}$ -2" / 25-63mm

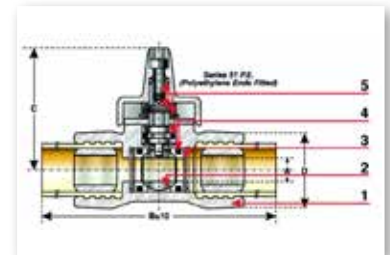

Code	DN mm	A mm	B mm	C mm	D mm	Weight Kg	Delivery Code
451252057413001	25x $\frac{3}{4}$ "	11.5	197	72	35	0.87	C
451323057413001	32x1"	14.5	201	73	43	1.1	C
45163605-7413001	63x2"	30	291	84	71	3.1	C

Transition Coupler

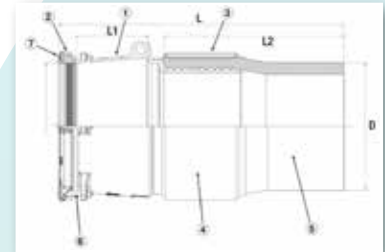

- PN2
- GIS/PL3
- Ductile Iron
- d90x3" - 355x12"

Code	D (Size Range)	Range	L	L1	L2	Weight	Delivery Code
	mm	mm	mm	mm	mm	Kg	
6041060901661000	90mm SDR17x3"	84-106	734	161	500	7.35	C
6041330901661000	90mm SDR17x4"	109-133	739	164	500	7.35	C
6041331251661000	125mm SDR17x4"	109-133	743	164	500	8.55	C
6041831251661000	125mm SDR17x6"	157-183	754	170	500	11.42	C
6041831801661000	180mm SDR17x6"	157-183	735.5	170	500	11.42	C
6042422501661000	250mm SDR17x8"	218-242	770	180	500	16	C
6042922501661000	250mm SDR17x10"	266-292	783	190	500	16	C
6042923151661000	315mm SDR17x10"	266-292	775	190	500	19.62	C
6043273151661000	315mm SDR17x12"	301-327*	787	195	500	42.59	C
6043503151661000	315mm SDR17x12"	324-350	792	200	500	46.75	C
6043273551661000	355mm SDR17x12"	301-327	787	195	500	58.72	C
6043503551661000	355mm SDR17x12"	324-350	792	200	500	61.83	C

PE 100 Flange Adaptor

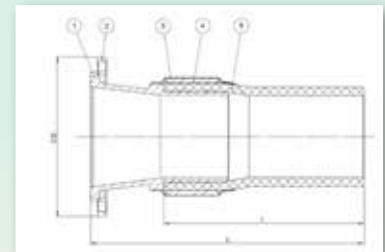

- PN4/7
- PN16 or ASA flanges
- Ductile Iron
- GIS/PL3
- EN 1092 (ISO 7005-2)
- d63-400

Code	DN	PE Pipe Size	D	df	L	I	Weight	Delivery Code
	mm	mm	mm	mm	mm	mm	Kg	
39063500012030	50	63	165	35	636	500	5	C
39090500112030	80	90	200	35	636	500	7	C
39090500212030	100	90	220	35	641	500	8	C
39125500212030	100	125	220	35	637	500	11	C
39125500312030	150	125	285	36	651	500	16	C
39180500312030	150	180	285	36	657	500	20	C
39180500412030	200	180	340	37	663	500	25	C
39250500412030	200	250	340	37	657	500	43	C
39250500512030	250	250	400	40	685	500	52	C
39315500512030	250	315	400	40	685	500	64	C
39315500612030	300	315	455	42.5	692	500	75	C
39355500612030	300	355	455	42.5	692	500	90	C
39315500712030	350	315	505	44.5	696	500	81	C
39355500712030	350	355	505	44.5	696	500	98	C
39355500812030	400	355	565	47	718	500	108	C
39400081204101	400	400	565	38	1088	1000	135	C

FLOW LIMITORS

FOR GAS AND WATER

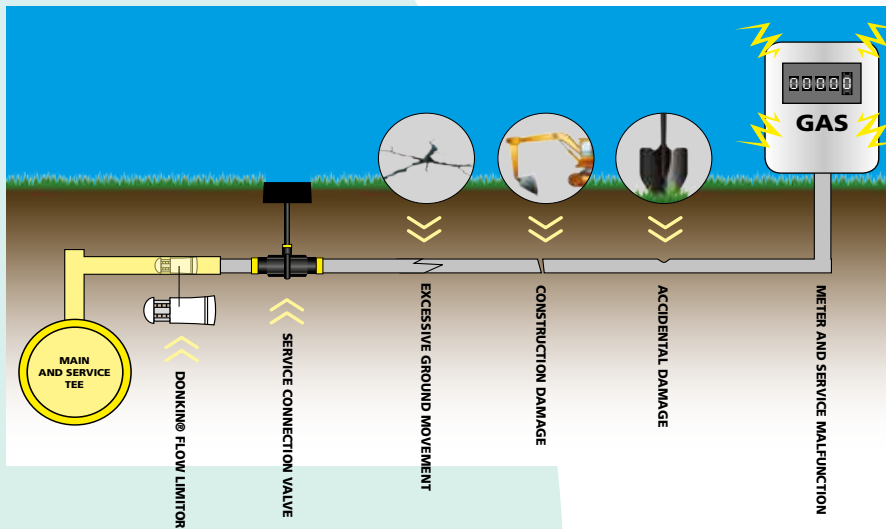

Series 310 Flow Limitor range of emergency shut-off valves provide service line safety, service line theft protection and automatic shut off.

Should gas flow exceed limits the flow limiter will simultaneously trip and shut-off the gas, remaining closed until repairs have been made. Once the fault has been rectified, a small bleed-by flow enables the service to regain pressure, equalising the pressure with the main. The unit will automatically reset for normal operation without intervention.

The range consists of products that fit in the service pipe, tapping tee outlet and also integrated into electrofusion reducers. Sizes range from d25 to 32 with products approved to standards such as GIS/EFV1, MSS SP 115 or BGE/S/V/5.

Features

- Tamper proof and maintenance free.
- Direction of flow indicator permanently moulded into the valve to ensure correct installation.
- Automatic self-acting operation.
- Installation at any angle.
- Bleed-by design provides automatic reset.
- All units are individually tested.

Integral Flow Limitor

- Series 310/061-001
- d32 Integral Flow Limitor
- Kitemark approved to GIS/EFV1
- (Fits in tapping tee outlet)
- Range: 75 mBar - 2 Bar
- d32



Code	d	PN	Weight	Delivery Code
	mm	Bar	Kg	
310-032-00-6101	32	2	0.03	A

- Series 310/063
- d32 Integral Flow Limitor Approved to MSS SP-115
- (Fits in Tapping Tee Outlet)
- Range - 0.69 - 6.9 Bar
- d32



Code	d	PN	Weight	Delivery Code
	mm	Bar	Kg	
310-032-00-6103	32mm	6.9	0.4	A

- Series 310/066-001
- d25 Integral Flow Limitor
- Approved to BGE/S/V/5 and MSS SP-115
- (Fits into service pipe)
- Range: 500 mBar - 4.0 Bar
- d25



Code	d	PN	Weight	Delivery Code
	mm	Bar	Kg	
310-025-00-6106	25	4	0.4	A

- Series 310/067-001
- d32 High Capacity Integral Flow Limitor
- Approved to BGE/S/V/5 and MSS SP-115
- (Fits into service pipe)
- Range: 500 mBar - 4 Bar
- d32



Code	d	PN	Weight	Delivery Code
	mm	Bar	Kg	
310-032-00-6107	32	4	0.4	A

Electrofusion Integral Flow Limitor

- Series 310/080
- Integral Flow Limitor Approved to MSS SP-115
- (Fits into electrofusion coupler or reducer)
- Range: 0.69 Bar - 7 Bar
- d32 x 20, 25 and 32



Code	d	PN	Weight	Delivery Code
	mm	Bar	Kg	
310-032-00-8200	32x20	7	0.07	A
310-032-00-8000	32x25	7	0.07	A
310-032-00-8100	32x32	7	0.07	A

Coupler with Excess Flow Valve



- PE100
- Water PN 16
- Gas 10 Bar
- d20-32

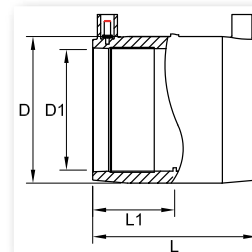

4.7mm Pin Fitting Code	Fitting Size	L	L1	D	D1	Fusion Time	Cooling Time	Weight	Box Quantity	Box Size (W X L X D)	Delivery Code
	mm	mm	mm	mm	mm	secs	mins	Kg		mm	
CBKHA20EFV	20	77	37.5	29	20	35	3	0.033	80	295 X 485 X 199	A
CBKHA25EFV	25	77	37.5	33.5	25	30	3	0.037	80	295 X 485 X 199	A
CBKHA32EFV	32	77	37.5	43	32	45	3	0.057	80	295 X 485 X 199	A

Pressure / flow specifications

Type	35M BAR	AT PRESSURE 75M BAR		AT PRESSURE 2 BAR			AT MAXIMUM PRESSURE 4 BAR			
	max. nominal flow air (m³/h)	max. nominal flow nat. gas (m³/h)	trip flow min. (m³/h)	trip flow max. (m³/h)	max. nominal flow nat. gas (m³/h)	trip flow min. (m³/h)	trip flow max. (m³/h)	nominal flow nat. gas (m³/h)	trip flow min. (m³/h)	trip flow max. (m³/h)
GS25Z	13	17	21	25	28	36	41	37	46	53
GS20Z	7	9	12	13	15	19	22	20	25	29

GS25Z / GS20Z	AT MINIMUM PRESSURE 1 BAR	AT MAXIMUM PRESSURE 4 BAR	REMARKS
Bypass flow rate (approx), large orifice	0.6 m³/h natural gas	1.5 m³/h natural gas	Transco requirements

Reducer with Excess Flow Valve



- PE100
- Water PN 16
- Gas 10 Bar
- d25x20 - 32x25

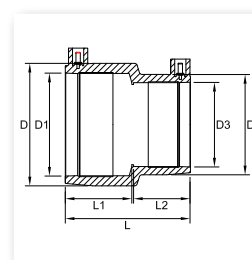

4.7mm Pin Fitting Code	Fitting Size	L	L1	D	D1	L2	D2	D3	Fusion Time	Cooling Time	Weight	Box Quantity	Box Size (W X L X D)	Delivery Code
	mm	mm	mm	mm	mm	mm	mm	mm	secs	mins	Kg		mm	
RBKHA25X20EFV	25 x 20	77	38.5	34	25	36.5	29	20	35	3	0.035	80	295 X 485 X 199	A
RBKHA32X20EFV	32 x 20	77	38.5	43	32	36.5	29	20	40	3	0.048	75	295 X 485 X 199	A
RBKHA32X25EFV	32 x 25	77	38.5	43	32	36.5	34	25	30	3	0.052	75	295 X 485 X 199	A

Pressure / flow specifications

Type	35M BAR	AT PRESSURE 75M BAR		AT PRESSURE 2 BAR			AT MAXIMUM PRESSURE 4 BAR			
	max. nominal flow air (m³/h)	max. nominal flow nat. gas (m³/h)	trip flow min. (m³/h)	trip flow max. (m³/h)	max. nominal flow nat. gas (m³/h)	trip flow min. (m³/h)	trip flow max. (m³/h)	nominal flow nat. gas (m³/h)	trip flow min. (m³/h)	trip flow max. (m³/h)
GS25Z	13	17	21	25	28	36	41	37	46	53
GS20Z	7	9	12	13	15	19	22	20	25	29

GS25Z / GS20Z	AT MINIMUM PRESSURE 1 BAR	AT MAXIMUM PRESSURE 4 BAR	REMARKS
Bypass flow rate (approx), large orifice	0.6 m³/h natural gas	1.5 m³/h natural gas	Transco requirements



EQUIPMENT AND ANCILLARIES

Fusion Group supplies a comprehensive range of equipment and ancillary tooling to help you achieve perfect joints across all pipe diameters.



Gator - Automatic Butt Fusion

The gator range of machines have been designed and developed to be used on gas and water pressure polyethylene pipes for distribution networks.

The best possible control of the joining process is achieved through an integral computer which will control and monitor all the joining parameters: time, temperature, pressure, movement and sequence. The welding process will not continue if any of these parameters are not within the specified limits contained in the selected welding standard.

Designed and manufactured to meet or exceed GIS/PL2-3:2006 and ISO 12176-1:2012

Features

- New computer, simplified and improved user interface, bright screen display and multilingual operation.
- New blue-tooth connectivity to facilitate real time transfer and control of joint data, using BlueBox by ControlPoint.
- Will work in conjunction with BDI bead testing equipment to ensure 100% success on every joint.
- On screen access to joint records, download to USB, and upload in JointManager website.

Standards

- ISO12176 - 1 : 2012
- GIS / PL2 - 3 : 2006
- ISO12176 - 3 Operator Badge (with optional barcode reader fitted)
- ISO12176 - 4 Traceability Coding (with optional barcode reader fitted)

Data Output

- Printer - Thermal Paper
- USB Memory device - Text file / JointManager
- Bluetooth - ControlPoint/BlueBox



Memory

- Internal memory capacity - Up to 2,000 records
- Back up to SD card - Up to 1000,000 records
- Via ControlPoint - Unlimited

Available on request

- Knife-edge conversion
- Stub flange adaptor

Removable clamp

The fourth clamp on the Gator can be removed to facilitate the butt fusion of long spigot fittings.

Ancillaries

- Pipe support rollers
- Debeaders
- Generators



GATOR COMPUTER - PROVIDES THE ULTIMATE IN CONTROL AND USER EXPERIENCE



Download to USB and upload in the JointManager website



Multilingual display



Simple user interface



Bluetooth connectivity to facilitate real time transfer and control of joint data using BlueBox by ControlPoint



Fully automatic features

1. Machine sequencing
2. Trim and feathering cycle
3. Pipe slippage check
4. Static and dynamic drag measurement
5. Heater plate temperature control
6. Initial bead up distance control
7. Heater retraction
8. Pressure control at bead up, soak, fusion, and cool time phases
9. Out of specification early warnings

Operator contribution

1. Input pipe and operator details
2. Inspect and approve trim

Continuously monitored

- Temperature - °C
- Movement - mm
- Pressure - Bar
- Time - Secs
- Trimmer current - Amps
- Heater continuity - Ω
- Pipe slippage - mm
- Oil Level - ml

Preprogrammed parameters



1. 15 internationally approved welding standards containing specified:
 - Heater temperatures
 - Fusion pressures
 - Soak times
 - Cooling times
2. Data management systems
3. Diagnostic routines

Gator - Specification

Code	GATOR 180		GATOR 250		GATOR 315		GATOR 400	
Range	63 - 180		63 - 250		90 - 315		200 - 400	
Nominal Input voltage (V)	110	220	110	220	110	220	110	220
Input frequency (Hz)	50 /60	50/60	50/60	50/60	50/60	50/60	50/60	50/60
Generator rating (KVA)	3.5	3.5	4.0	4.0	6.0	6.0	7.0	7.0

Gator - Order Codes



Code	Gator Size	Description	Plug Type	Delivery Code
G180110AFE	180	110 volt - yellow 3 pin plug		B
G250110AFE	250			
G315110AFE	315			
G400110AFE-2	400			
G180220AFG	180	220 volt - black 2 pin plug		B
G250220AFG	250			
G315220AFG	315			
G400220AFG-2	400			
G180220AFE	180	220 volt - blue 3 pin plug		B
G250220AFE	250			
G315220AFE	315			
G400220AFE-2	400			

Gator - Optional Extras

Code	Description	Delivery Code
See table below	Gator Liners	A
705892	Advanced thermal printer	A
704504	Barcode reader for ISO standard traceability	A
Contact the Fusion Sales team for details	BlueBox	C

Gator Liners



Butt Fusion liners are designed to maximise the size range of the machine. All sizes are available in cast aluminium, and sizes up to 180mm diameter are also available in an engineering plastic called Noryl. Noryl liners are extremely tough and very light.

Aluminium code	Plastic code	Size	To fit machine sizes	Delivery Code
		mm		
BFL400355	N/A	400x355	400	A
BFL400315	N/A	400x315	400	A
BFL400250	N/A	400x250	400	A
BFL315280	N/A	315x280	400, 315	A
BFL315250	N/A	315x250	400, 315	A
BFL315200	N/A	315x200	400,315	A
BFL250225	N/A	250x225	400,315,250	A
BFL250200	N/A	250x200	400,315,250	A
BFL250180	BFL250180PT	250x180	400,315,250	A
BFL250160	N/A	250x160	400,315,250	A
BFL180160	BFL180160PT	180x160	315,250,180	A
BFL180140	BFL180140PT	180x140	315,250,180	A
BFL180125	BFL180125PT	180x125	315,250,180	A
BFL180110	BFL180110PT	180x110	315,250,180	A
BFL18090	BFL18090PT	180x90	315,250,180	A
BFL18075	BFL18075PT	180x75	250,180	A
BFL18063	BFL18063PT	180x63	250,180	A

THE GOOD GUIDE TO BUTT FUSION JOINTING



This guide will provide basic information to enable the operative to:

- Understand the equipment required.
- Understand the principles of polyethylene (PE) pipe butt fusion jointing.
- Identify pipe and appropriate fitting markings.
- Site the equipment.
- Carry out pre-jointing machine and equipment checks.
- Make satisfactory butt fusion joints across a range of pipe sizes.
- Inspect for, and identify acceptable quality joints including de-beading.

Equipment required:



Generator of suitable size to power butt fusion machine - refer to manufacturers' literature for power requirements



Butt fusion machine of suitable size and liners (if required)



Pipe support rollers



Welding tent/shelter and ground sheet



External / Internal de-beading tool



Pipe end covers



Pipe cutter



Indelible marker pen for marking beads

THE GOOD GUIDE TO BUTT FUSION JOINTING



Principles

The pipes to be joined are held in clamps which grip and re-round the pipe. Clamps are hydraulically operated by hand pumps or electrically driven pumps. Clamp movement is controlled by the operator in the case of manual / semi-automatic machines, in automatic machines the computer controls clamp movement during the automatic cycle.

Pipe ends are prepared by planing with an electrical driven trimmer, then heated using an electrically powered non-stick heater plate. When molten, the pipe ends are brought together and held under pressure until cooled.

Pipe Selection ID

Check that both pipes to be joined are of the same size, SDR (standard dimension ratio) and material. Only compatible sizes and material should be joined together. If in doubt, seek advice from the pipe manufacturer. Pipe information is marked on the pipe at approximately one metre intervals.

Siting Equipment

Wherever possible, the butt fusion machine should be placed on a suitable clean, dry base board or ground sheet inside a tent / shelter to minimise contamination and wind chill.



Arrange the machine so there is enough room to get around the machine to carry out the work, route the cables and hoses so they don't cause a trip hazard.

Pre-Jointing Checks

- Use only equipment which has been regularly serviced and is in good condition.
- Ensure the correct jointing parameters for the machine and pipe being welded are known and understood.

- Ensure that the generator is maintained and serviced to the manufacturers requirements and has sufficient fuel to carry out the work to be done.
- Ensure that the generator has been suitably earthed to the generator manufacturers requirements.
- Check that the heater plate coating is not damaged and is clean – wash only when cold with clean water and dry with a clean lint-free cloth or paper towel.
- Check that the trimmer is clean and that the blades are not damaged and are in good condition.
- Ensure clamp liners and securing screws of the correct size are available for the size of pipe to be joined. Liners must be clean and sit fully in the pipe clamps thus ensuring correct alignment.
- Check that the heater plate is at the correct temperature. Ensure correct parameters are selected for pipe to be joined.

Dummy Joint

To make dummy welds follow the jointing procedures or abort the cycle after the full soak time has elapsed then open the machine and remove the heater. The first print out should read 'Error 20: Abort during Fusion.' Alternatively, allow the joint to complete and cut out the joint(s) once cooled. Some welding standards will force one or two dummy welds.

MAKING THE JOINT

Automatic Welding Procedure

The welding procedure detailed below has been summarised from the manufacturers comprehensive operating instructions and is only intended as a guide. Always familiarise yourself fully with the manufacturers operating instructions, safety operation and controls before commencing work.

Stop / Reset Button

In an emergency press the Emergency Stop Button on the back of the controller, when pressed it will immediately cut the generator supply to the machine.

Dummy welds should be made (to remove any fine particles from the heater plate) before every welding session, after changing from one pipe size to another and also if the heater has been allowed to cool.

Connection and Pipe Selection

1. Connect heater, chassis and trimmer cables to the computer.
2. Ensure the hydraulic connections are clean and then connect to the controller.
3. Start the generator and then connect the controller to the generator.
4. Select the pipe size and type to be jointed.
5. Confirm data.

Pipe Preparation

1. Load and secure trimmer into machine using the fast clamp system. Push down knobs and turn clockwise to lock.



2. Place pipes to be joined on the pipe support roller to reduce drag.

3. Cover pipe ends that are not being jointed to prevent draughts.
4. Clean pipe ends inside and out (approx. 300mm) then load and position pipes lightly against trimmer discs with writing on pipe uppermost.
5. Position toggle lever into place and use adjustment knob (clockwise to tighten and anti-clockwise to loosen). Snap shut the fast clamps around the pipe.



6. Press 'Green' button on controller. Trimming will continue up to its programmed stop, but as soon as a running swarf strip of full pipe thickness is visible, the 'feathering off' phase can be initiated by pressing the 'Green' button again. Without operator intervention, the machine will automatically enter the 'feathering off' phase of the trimmer cycle.



7. When trimming cycle is completed and carriage has opened, remove trimmer and swarf. Pull swarf through the bottom of the frame. Be careful not to touch pipe ends.



DO NOT PULL SWARF UP THROUGH TRIMMED PIPE ENDS, AS THIS MAY CONTAMINATE THE PIPE FACES

8. Visually check pipe ends for completeness of trimming.



9. Press 'Green' button to close carriage then visually check pipe alignment, adjust clamps removing ONLY one toggle clamp at any one time to adjust alignment if required then re-check and re-trim if necessary.



THE GOOD GUIDE TO BUTT FUSION JOINTING

MAKING THE WELD

1. After the 'check' and prior to the 'join' phase secure the heater to the chassis. Push down knob and turn clockwise to lock.
2. Press 'Green' button on computer, this checks heater temperature, if the heater is correct temperature then the chassis will open. The chassis will not open until the correct temperature has been achieved.
3. Insert the heater into the chassis, push home until fully locked.



4. Press 'Green' button again. Fusion cycle will be carried out automatically. Display will give 'relevant' information at all times.
5. When controller display shows 'JOINT COMPLETE', press 'Green' button.



6. Remove the heater from the chassis, place in heater / trimmer stand.
7. Allow pipe to cool properly (in accordance with specification) before releasing from the clamps.
8. Unclamp pipe and remove carefully.

Quality Checks

- Check visually for excessive irregularity in bead formation and pipe mismatch.
- Externally de-bead the weld.
- Visually check the underside of the removed bead for contamination, then bend back at several positions and inspect for slit defects.
- Check for cleanliness around joint area.
- Print out or download the joint data from the controller using Data Printer, USB stick or MiniTran. Check the results and verify the details for correct compliance.

BUTT FUSION DO'S

- In cold temperatures the chassis should be opened and closed manually approximately 10 times in quick succession following the automatic warm up routine.
- Always ensure that the equipment is calibrated and properly maintained.
- Always weld inside a shelter on a suitable baseboard or ground sheet.
- Where possible, site the equipment on clear level ground.
- Always ensure pipes are aligned correctly and supported on pipe rollers to minimise drag.
- Cover open pipe ends to eliminate wind chill to the heater and joint interface.
- Clean pipe surfaces (inside and out), pipe ends and clamps before inserting pipe into the machine.
- Position pipes into the clamps with the pipe marking uppermost and aligned.
- Wash the heater plate when cold before every welding session and perform dummy welds when hot to remove fine particles from the heater surface. On pipe sizes above 180mm, two dummy welds should be made at the start of each session.
- Perform dummy welds after changing from one pipe size to another, also if the heater plate has been allowed to cool.

- Clean trimmer discs and blades before use.
- Ensure that when trimming, a continuous ribbon of material, of complete pipe wall thickness is produced from both pipe ends before stopping the trimmer and advancing to the feathering operation.
- Always wait for the trimmer to stop rotating before removing it from the machine.
- Replace the trimmer in the stand provided.
- Remove shavings from pipe ends and chassis. Pull swarf through the bottom of the frame be careful not to touch pipe ends.
- Check visually that both pipe ends are completely trimmed.
- Always check pipes for alignment ensuring no gaps exist between the two pipe ends around the entire circumference of the abutted pipes.
- On completion of satisfactory alignment checks, proceed with the welding cycle without delay.
- Number/code the joint and bead using an indelible marker.
- After FULL cooling time has elapsed, remove either external or internal bead and carry out quality checks.

BUTT FUSION DONT'S

- Do not attempt to open the computer enclosure – there are no user serviceable parts inside.
- Do not use damaged equipment.
- Do not attempt to weld pipes of different material, diameter or SDR.
- Do not leave shavings inside pipe or on the chassis.
- Do not introduce dirt onto trimmed pipe ends whilst removing swarf.
- Do not touch trimmed pipe or fitting ends.
- Do not remove pipes from the machine before the complete cooling time has elapsed.
- Do not cut corners in any part of the welding cycle.
- Do not attempt to install pipe until fully cooled.

SAFETY NOTES

Although we make every effort in the design of our products to ensure operator safety, please remember the following precautions:

- Do not touch heater plate when hot.
- Never allow molten or semi-molten polyethylene to come into contact with the skin. However, if this does happen, flush the affected area with cold water and seek expert medical advice.

DO NOT UNDER ANY CIRCUMSTANCE ATTEMPT TO PULL THE MATERIAL FROM THE SKIN AS THIS COULD REMOVE THE SKIN AS WELL.

- Avoid contact with the trimmer blades when cleaning discs and especially when in motion. These can be sharp and cause cuts to fingers etc.
- Do not attempt to operate the trimming device whilst out of the machine chassis or attempt to by-pass the safety switch.
- Keep fingers and hands away from the pipe ends, chassis, trimmers and heaters whilst operating the machine.
- Do not attempt to lift heavy equipment or long lengths of pipe without assistance or mechanical aid.
- An audible alarm is fitted to automatic butt fusion machines to warn of impending movement.
- Remove all traces of polymer from the heater face(s) to prevent the production of fumes from degraded residues (at normal jointing temperatures the production of fumes will be slight, however these will be more pronounced at higher temperatures). Advice regarding Health & Safety in reference to the pipe material can be obtained from the pipe supplier.

- Normal precautions should be observed when handling electrical equipment and for safety reasons, all 110V portable generator sets should be "Centre Tapped" for site use 55V-0V-55V volts.
- To afford protection against unforeseen circumstances occurring during jointing it is advisable to wear protective workwear such as gloves, safety glasses and safety boots.





Manual Butt Fusion

Manual machines are part of the hydraulic range of butt fusion machines. They are suitable for welding polyethylene pipes for gas and water pipeline projects and also polypropylene pipes used in industrial applications.

- 150 bar system pressure
- Versatile 4 piece design ideal for in trench work

- Protective heater and trimmer stand
- Sliding 3rd chassis clamp allows for jointing of fittings
- Anti-drip quick release hydraulic couplings
- Electronic adjustment of temperature
- Safety micro switch on trimmer
- Double edge trimmer blades



Code	Machine	Range	Weight (kg)	Voltage - frequency	Power specification (kW)	Delivery Code
		mm	Kg		kW	
W1602300M	Welda 160	40-160	90	230V - 50/60Hz	2.6	C
W2502300M	Welda 250	90-250	118	230V - 50/60Hz	3.1	C
W3152300M	Welda 315	90-315	143	230V - 50/60Hz	3.8	C
W5002300M	Welda 500	250-500	300	230V - 50/60Hz	6.0	C
W6304000M	Welda 630	250-630	430	400V 3P+N - 50/60Hz	10.7	C
W8004000M	Welda 800	400-800	1020	400V 3P+N - 50/60Hz	15.7	C
W10004000M	Welda 1000	500-1000	1934	400V 3P+N - 50/60Hz	20.9	C
W12004000M	Welda 1200	630-1200	2130	400V 3P+N - 50/60Hz	20.0	C

Stub flange adaptors

Code	Welda machine size	Overall dimension	Weight	Delivery Code
	mm	mm	Kg	
WSFA160	160	Ø 215	4	C
WSFA250	250	Ø 318	8	C
WSFA315	315	Ø 385	10	C
WSFA500	500	Ø 585	32	C
WSFA630	630	Ø 685	40	C
WSFA800	800	Ø 905	90	C
WSFA1000	1000	Ø 1110	105	C
WSFA1200	1200	Ø 1330	140	C

Lifting crane

Code	Delivery Code
N/A	C
N/A	C
N/A	C
N/A	C
WLC630	C
WLC800	C
WLC1000	C
WLC1200	C

Manual Butt Fusion Liners



Code	Size	To fit machine sizes	Delivery Code
	mm		
WFL12001000	1200x1000	1200	C
WFL1000900	1000x900	1200, 1000	C
WFL1000800	1000x800	1200, 1000	C
WFL800710	800x710	1200, 1000, 800	C
WFL800630	800x630	800	C
WFL630560	630x560	800, 630	C
WFL630500	630x500	800, 630	C
WFL500450	500x450	630, 500	C
WFL500400	500x400	630, 500	C
WFL500355	500x355	630, 500	C
WFL500315	500x315	630, 500	C
WFL315280	315x280	500, 315	C
WFL315250	315x250	500, 315	C
WFL250225	250x225	315, 250	C

Code	Size	To fit machine sizes	Delivery Code
	mm		
WFL250200	250x200	315, 250	C
WFL250180	250x180	315, 250	C
WFL250160	250x160	315, 250	C
WFL250140	250x140	315, 250, 160	C
WFL250125	250x125	315, 250, 160	C
WFL250110	250x110	315, 250, 160	C
WFL25090	250x90	315, 250, 160	C
WFL160140	160x140	250, 160	C
WFL160125	160x125	250, 160	C
WFL160110	160x110	250, 160	C
WFL16090	160x90	250, 160	C
WFL16075	160x75	160	C
WFL16063	160x63	160	C
WFL16050	160x50	160	C
WFL16040	160x40	160	C



External Debeaders

Used to remove external beads after butt fusion joint completion. External bead removal plays a key role in establishing joint integrity and is necessary when undertaking slip-lining or swage lining projects.

- Easily adjusts to pipe diameter, allowing the blade to cut under the bead without damaging the surface of the pipe
- High quality heat treated ground cutting blades
- Replacement blades available
- Comes complete with storage box



Code	Range	Weight	Spare blade code	Delivery Code
	mm	Kg		
EXTDB	125mm - 400mm	3	EXTDBBLADE	A
EXTDBL	355mm - 630mm	4	EXTDBLBLADE	A
EXTDBXL	400mm - 900mm	5	EXTDBXLBLADE	A

Internal Debeaders

The internal debeader is a manual kit for the simple and effective removal of internal beads formed during the butt fusion process. The internal debeader can de bead polyethylene pipes in the size range 110mm - 400mm (450mm with adaptor).

- Rods can be quickly clipped together to de bead pipe lengths up to 13m
- Bead retained in head after removal process for later inspection/ archiving
- Robust build quality
- Simple to assemble
- Facilitates quality control procedures from visual bead inspection and bend back test
- Rods come in robust canvas bag
- Heads and ancillary components are housed in a steel box with carry handles



Code	Description	Weight	Delivery Code
		Kg	
IBRTKIT	Internal bead removing tool 110 - 400mm	70	A
31681	Spare blade for head 1 and 2	N/A	A
32187	Spare blade for head 3 and 4	N/A	A

IBRTkit contains	
Code	Description
11769	1 x storage box
11560	1 x drive handle
21459	1 x no. 1 size head
21457	1 x no. 2 size head
21453	1 x no. 3 size head
21451	1 x no. 4 size head
N/A	2 x Allen keys
N/A	1 x set operating instructions
32740	3 x size 1 rod supports
31754	3 x size 2 rod supports
21803	3 x size 3 rod supports
21310	3 x size 4 rod supports
21859	3 x size 4b rod supports
69046	1 x rod bag
21560	6 x 2 meter rods
21618	1 x 1 meter rod

Selection Chart						
SDR	44	32	26	17	11	7.3
O/D	Head Size					
110				1(B)	1(A)	
125				1(D)	1(C)	1(A)
140				1(A)	1(D)	1(C)
160	2(B)	2(B)	2(B)	2(B)	2(B)	1(D)
180	3(A)	2(C)	2(C)	2(C)	2(B)	2(B)
200	3(A)	3(A)	3(A)	3(A)	2(C)	2(B)
225	3(B)	3(B)	3(B)	3(B)	3(A)	2(C)
250	3(C)	3(C)	3(C)	3(C)	3(B)	3(A)
280	4(B)	4(B)	4(B)	3(C)	3(C)	3(B)
315	4(C)	4(C)	4(C)	4(B)	4(A)	3(C)
355	4(D)	4(D)	4(D)	4(C)	4(C)	4(A)
400				4(D)	4(C)	4(B)
450				4(D)	4(D)	

Note: Each debeader head size has multiple settings. These are referred to in the table as A, B, C or D. To select the correct head size you will need to know the outer diameter of the pipe you wish to de bead (see first column) and its SDR.

Note: The above items are also available as spares

Internal Debeaders - Optional Extras



Code	Description	Delivery Code
91425	Adaptor for 450mm SDR11	A
91474	Adaptor for 450mm SDR17.6	A
51416	Screw (2 per adaptor)	A

ClearBore Internal Debeader

The ClearBore internal debeader is specifically designed to leave an absolutely 'snag free' passage in cable ducting applications.

- Simple to use and similar functionality to Fusion's standard internal debeader.

- Simple and solid construction with a sprung cutter giving positive location on the bead.
- The debeader works on both PE80 and PE100 pipe up to 13m in length and diameters up to 250mm

Note - Not suitable for pressure pipe applications



Code	Description	Range	Weight	Delivery Code
		mm	Kg	
IBRTKIT100	Internal bead removal tool	110 - 250mm (SDR 9 and 11)	63	C

Note - Other sizes are available upon request.

IBRTkit100 contains	
Description	Quantity
Debeading head	1
Drive plate	1*
Drive adaptor	1
2 metre rod	6
1 metre rod	1
Handle	1
Rod supports	3*
Rod bag	1
Storage box	1
Flat blade screw driver	1
17mm spanner	1
6mm Allen Key	1
Operating instructions	1

Selection Chart				
Pipe Diameter	SDR	Drive Plate Code	Rod Support Code	Support Diameter
				mm
110	11	23475	36119/110SDR11	80
125	9	23513	36119/125SDR9	87
125	11	23477	36119/125SDR11	92
160	11	23479	36119/160SDR11	121
180	11	23481	36119/180SDR11	137
200	11	23511	36119/200SDR11	154
225	11	23483	36119/225SDR11	174
250	11	23485	36119/250SDR11	195

Note - * Kit includes 1 drive plate and corresponding rod supports. Please specify size of drive plate and rod supports required at the time of ordering from the table above.



Pipe Lifter 400

The Pipe Lifter 400 is a simple, robust and effective device which assists with the ejection and movement of polyethylene pipes during the welding process.

- Simple lever mechanism which improves productivity
- Heavy duty construction
- Folds flat for easy storage and transportation
- Works in conjunction with pipe support rollers
- Compatible with all butt fusion machines from 180mm to 400mm



Code	Description	Range	Weight	Delivery Code
		mm	Kg	
PIPELIFT400	Pipe Lifter 400	up to 400mm	22	A

Pipe Support Rollers

A range of adjustable pipe support rollers, used to assist the butt fusion welding process

- 3 adjustable pipe rollers covering the range 63mm to 630mm
- Rigid construction, with all models supplied as a pair



315 Adjustable roller 400 Adjustable roller 630 Adjustable roller

Code	Description	Range	Weight per roller	Delivery Code
		mm	Kg	
PSROLL315	315 adjustable roller (pair)	63-315mm	5	B
PSROLL400	400 adjustable roller (pair)	63-400mm	18	B
PSROLL630	630 adjustable roller (pair)	315-630mm	52	B

Printer/Data Retrieval

Portable printer for use with Gator controller.

- The printer provides the installer with documentary evidence of good working practices
- Lightweight, compact and portable



Printer, lead and roll



Gator controller with printer in operation

Code	Description	Delivery Code
705892	Advanced thermal printer, lead and roll	A
705893	Lead only	A
705799	Paper roll	A



SBOX Max - Electrofusion

- SBOX Max can weld Fusamatic fittings from 20mm to 630mm diameter.
- The screen is protected by hard-wearing scratch-resistant polycarbonate.
- Pin adaptors included as standard. Welds both 4mm and 4.7mm pin fittings.
- Comes with hard protective carry case. Easy to carry and designed to withstand knocks and scratches.
- On screen instructions in 15 languages. New languages being continually added.
- Graphics display with adjustable contrast and a wide viewing angle.
- The SBOX-Max's internal 'Black Box' SD card holds up to 100,000 joint records: a lifetime's joints safely stored.



Only 18kg in tough protective case



Display your logo on screen



Welds Fusamatic fittings between 20mm and 630mm



Cable tidy



USB data download



Multiple languages



Welds 4mm and 4.7mm pin fittings









ControlPoint ready



Barcode, manual and Fusamatic fittings



SBOX Max - Order Codes

Code	Description	Plug Type	Bar Code Scanner	Delivery Code
SBOXMAXBCG	SBOX Max 230V Electrofusion Welder with barcode scanner - black 2 pin plug			A
SBOXMAXBCE	SBOX Max 230V Electrofusion Welder with barcode scanner - blue 3 pin plug			A
SBOXMAXG	SBOX Max 230V Electrofusion Welder - black 2 pin plug		X	A
SBOXMAXE	SBOX Max 230V Electrofusion Welder - blue 3 pin plug		X	A

Note - all 220V/230V automatic electrofusion control boxes come with carry case and 4.0mm / 4.7mm lead end adaptors as standard.

SBOX Max - Specification

SBOX-Max / SBOX-MaxBC			
Supply	Minimum	Typical	Maximum
Input Voltage	195v	230v	265v
Input Frequency	40Hz	50Hz	60Hz
Generator Rating	4.2KVA	-	6KVA

SBOX-Max / SBOX-MaxBC			
Output	Minimum	Typical	Maximum
Output 40v Auto Fitting	39.0v	39.5v	40.0v
Output Voltage Barcode and Manual	10.0v	-	48.0v
Output Current	2A	-	60A
60% Duty Cycle output ISO12176-2		60A	
Peak Current <60seconds		80A	

Operating modes	SBOX-Max	SBOX-MaxBC
Fusamatic	20 - 900 Seconds	
Manual	10 - 3500 Seconds	
Barcode	NO	YES

Memory	SBOX-Max / SBOX-MaxBC
Internal Memory Capacity	Up to 2,000 records
Backup to SD Card	Up to 100,000 records
Via ControlPoint	Unlimited

Data output	SBOX-Max / SBOX-MaxBC
USB memory device	YES - text file/JointManager
Bluetooth	ControlPoint

SBOX-Max / SBOX-MaxBC		
Environment	Minimum	Maximum
Operating Temperature	-10°C	+40°C
Storage Temperature	-15°C	+55°C
Environmental Protection	IP54	

Weights	SBOX-Max	SBOX-MaxBC
Box with leads	16.8Kg	17.0Kg

Cable length	SBOX-Max / SBOX-MaxBC
Input Cable	3m
Output Cable	2.5m

Dimensions	Width	Depth	Height
(with cables coiled in cable storage)	30cm	29cm	43cm

Standards	SBOX-Max	SBOX-MaxBC
ISO12176-2 Electrofusion	YES	
ISO12176-2 Classification	P23US2FVKADX	
ISO12176-3 Operator Badge	-	YES
ISO12176-4 Traceability Coding	-	YES

SBOX-Lite 220v - Electrofusion

The SBOX-Lite is a lightweight and versatile electrofusion control box which is capable of welding any brand of electrofusion fittings for gas, water and other pressure pipe applications.

- Can weld Fusamatic electrofusion fittings in sizes 20mm - 125mm (140mm and 160mm couplers can be welded by letting the machine cool down between operations).
- The 220V SBOX-Lite can be used in 2 different modes -
 1. By barcode reading (8 - 48 volts)
 2. Manual entry of fusion voltage and time

- Extremely lightweight - only 8kg
- Joint data memory of 350 welds-downloadable to USB memory stick
- Fusion data transfer CD and USB cable adaptor included
- Ambient temperature compensation is applied when required
- 4.0 - 4.7mm diameter universal collet adaptor
- Multi-lingual selectable display
- Manual scraper included
- Transport bag included



Universal lead ends

I/P Plug



SBOX Lite - Order Codes

Code	Description	Range	Weight	Delivery Code
		mm	kg	
SBOXLITE220BC	SBOX Lite 220 volts	20-125mm	8	A

SBOX Lite - Specification

Diameters range (OD)	20 - 125mm *	Working temperature	- 10 °C to + 40 °C
Weldable materials	PE / PP/ PP-R	Welding voltage (V)	8V-48V
Dimensions (W x D x H)	200 x 250 x 210mm	Protection degree	IP 54
Weight	8 kg	Barcode scanner	Yes
Power supply (V)	230V ±15%	Pin connector sizes	4mm and 4.7mm universal
Frequency	50 - 60 Hz	Memory capacity	350 joints
Maximum absorbed power	2000W	Ambient temperature compensation	Yes
Nominal absorbed current	8A		
Peak output current	60 A		
Welding nominal current	23A		
Duty cycle 60% (ISO 12176-2)			

* OD 140mm and 160mm Fusamatic couplers can also be welded but with precaution, wait for the machine to cool off completely after each welding cycle.



Uniprep Scraper

Uniprep scrapers are high productivity tools, used for preparing pipe ends prior to electrofusion. Suitable for all pipe SDR's and pipe with ovality.

- Fast scraping action
- Heat treated ground steel cutting blade
- Accurately controlled depth of cut
- Quick release after pipe scraping using post locking screw

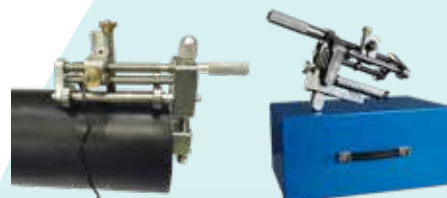

Code	Description	Weight	Spare Blade Code	Delivery Code
		Kg		
UNIPREP250	Uniprep scraper 63mm - 250mm	3	UNIPREP22	A
UNIPREP400	Uniprep scraper 90mm - 400mm	3.5	UNIPREP22	A
UNIPREP500	Uniprep scraper 125mm - 500mm	4	UNIPREP22	A
UNIPREP710	Uniprep scraper 450mm - 710mm	5	UNIPREP22	A

Universal Scraper

The universal scraper provides a convenient means of preparing pipe ends prior to electrofusion jointing. It can operate on all pipe diameters and commonly used SDR sizes from 63mm to 250mm inclusive, and can be used on coiled pipe and pipes with ovality.

- Correct length of scrape is pre-set
- Fixed, serrated blade driven around the pipe using ratchet handle
- Internal roller action holds the cutting blade against the pipe
- Carry case, spare blade and cleaning brush



Code	Description	Weight	Spare Blade Code	Delivery Code
		Kg		
UNISCRP	Universal scraper 63mm-250mm	4.5	370300	A

Multi Scrape

Multi Scrape is a versatile pipe scraper designed specifically with coiled pipe in mind. Mandrels support the pipe ends and a spring loaded blade, ensures that the optimum depth of cut is achieved.

- Comes with choice of solid or expandable mandrels

- Hardened steel blade design, indexable with two cutting edges
- Blade design ensures a consistent depth of cut
- Sprung loaded arm facilitates use on coiled and oval pipe
- All mandrels aid pipe re-rounding and cover a variety of pipe sizes and SDR's



Code	Description	Delivery Code
MULTISCRAPKIT	Tool including complete set of solid mandrels and spare blade in case	A
MULTISCRKITUK	Tool including 63mm SDR11/32mm/25mm solid mandrels only in case	A
MULTISCRKITEM	Tool including 20mm and 25mm solid mandrels and small, medium and large expanding mandrels in case	A

Diameter range	SDR Range	Case dimensions	Weight complete kit
			Kg
20, 25, 32, 40, 50, 55 and 63mm	11 and 17	275 x 225 x 90mm	2.5



Multi Scrape - Spare Parts



Expanding mandrels kit



Solid mandrels kit

Code	Description	Delivery Code
MULTISCAPE	Tool only	A
35571	20mm solid mandrel	A
35572	25mm solid mandrel	A
35573	32mm solid mandrel	A
35574	40mm solid mandrel	A
35575	50mm SDR11 solid mandrel	A
35576	50mm SDR17 solid mandrel and 55mm SDR11	A
35577	63mm SDR11 solid mandrel	A
35578	63mm SDR17 solid mandrel	A
35559	Spare blade	A
22902	Case	A
35794	Small expanding mandrel covers 32mm and 40mm	A
35795	Medium expanding mandrel covers 50mm (all SDR's)	A
35796	Large expanding mandrel covers 63mm (all SDR's)	A

Multi Clamp

The multi-clamp kit has been specifically designed for easier alignment and restraint of a whole range of electrofusion fittings and suits narrow trenching techniques.

- Facilitates full rerounding and restraint during electrofusion
- Top clamp hinges facilitates use in narrow trenches
- The dovetail assembly allows complete rotation through 360° to suit any pipe and fitting configuration (large diameter tees require extra base, ring and liners)
- Extruded lightweight base



Code	Basic	
	Weight	Delivery Code
MCKIT180B	Kg 9.5	A

1 x carrying bag
2 x basic 180mm rings + slide blocks
4 x 180mm x 125mm liner segments
4 x 125mm x 90mm liner segments
4 x 125mm x 63mm liner segments
1 x 600mm base
1 x allen key

Code	Universal	
	Weight	Delivery Code
MCKIT180	Kg 13.5	A

1 x plastic container
2 x basic 180mm rings + slide blocks
4 x 180mm x 125mm liner segments
4 x 125mm x 90mm liner segments
4 x 125mm x 63mm liner segments
2 x 460mm bases
1 x allen key
1 x spanner
1 x 'T' connector



Multi Clamp - Optional Extras and Spares

Code	Description	Delivery Code
12390	180mm ring	B
132000	460mm base	B
148500	600mm base	B
22541	180mm x 160mm liner segments	B
22540	180mm x 140mm liner segments	B
21607	180mm x 125mm liner segments	B
31784	160mm x 110mm liner segments	B

Code	Description	Delivery Code
33812	160mm x 75mm liner segments	B
33354	125mm x 90mm liner segments	B
33356	125 x 63mm liner segments	B
33358	T-connector	B
33470	Locking handle with screw (for base)	B
21692	45° convertor	B

Application and usage



Couplers and reducers



90° Electrofusion Elbows
(1 base / 2 Rings)



45° Electrofusion Elbows
(1 base / 2 Rings)



E/F tees and reducing tees
(3 bases / 3 rings / 1 'T' connector)



Electrofusion of Seamless Bends
(2 bases / 4 rings)

Mini Clamps

Mini clamps are designed to restrain and align pipe and fittings for service connections during the electrofusion process. The mini clamp is suitable for pipe sizes 20, 25 and 32mm.

- Interchangeable arms for each pipe size
- Reducers, couplers and tapping tee outlets can be accommodated
- Robust construction with cast aluminium body
- Promotes re-rounding and restraint during electrofusion



Interchangeable arms

Code	Description	Weight	Delivery Code
		Kg	
MINICLAMP	20, 25 and 32mm mini clamp	1	A



Versaclamp

A range of clamps that can be used on 90° and 45° elbows and straight connections. Available for use with 20, 25 and 32mm diameter pipe.

- Pocket size and ultra lightweight design
- Manufactured from a tough engineering plastic (Noryl)
- Works in tight spaces with flextee and multiseal



Code	Description	Weight	Delivery Code
		Kg	
VERSACLAMP20	20mm multi angled clamp	0.2	A
VERSACLAMP25	25mm multi angled clamp	0.2	A
VERSACLAMP32	32mm multi angled clamp	0.2	A



Straight Connections



90° Elbows



45° Elbows

Elbow Clamps

A very simple hand tool for clamping either 20, 25 or 32mm service pipe when fusing 90° elbows giving stress free joints.

- Compact lightweight design
- Manufactured from a tough engineering plastic (Noryl)



Code	Description	Weight	Delivery Code
		Kg	
ELBOWCLAMP20	Elbow clamp 20mm	0.1	A
ELBOWCLAMP25	Elbow clamp 25mm	0.1	A
ELBOWCLAMP32	Elbow clamp 32mm	0.1	A



90° Elbow clamp - 20mm pipe



90° Elbow clamp - 32mm pipe



90° Elbow clamp - 25mm pipe



Mini and Maxi Posi Clamps

Two lightweight versatile electrofusion clamps working in the range 20 - 40mm and 32 - 63mm.

- Can be used for couplers, reducers, end caps, equal tees, 45° and 90° elbows and reducing tees
- Can be used on multiseal tapping tees where couplers are connected to the outlet
- Aligns, and secures the pipe to prevent movement of fittings during fusion and cooling
- Made from a tough engineering plastic (Noryl)
- All nuts and adjustments are fully captive and therefore cannot be lost



Code	Description	Range	Weight	Delivery Code
			Kg	
MINIPOSI	Couplers, reducers, end caps, equal and reducing tees, 45° and 90° elbows	20mm, 25mm, 32mm and 40mm	0.5	A
MAXIPOSI	Couplers, reducers, end caps, equal and reducing tees, 45° and 90° elbows	32mm, 40mm, 50mm and 63mm	1.0	A



Maxi Posi clamp 90° Elbow



Maxi Posi clamp on Multiseal tapping tee



Maxi Posi clamp coupler

Alignment Clamps

Heavy duty alignment clamps, used for jointing of 250mm electrofusion couplers.

- Hinged with pins for ease of pipe positioning in trench - facilitates use in narrow trenches
- Offers full rerounding and restraint of pipe and fitting during welding
- Fixed clamp position
- Robust construction
- Liners available for smaller sizes

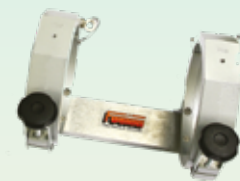

250 Alignment clamp

Code	Description	Weight	Delivery Code
		Kg	
01-15-014	250mm alignment clamp	14	B

Top Load Clamp

Strap clamp for use on top loaded saddles.

- Lightweight
- Universal
- Ideal for use in confined spaces



Quality Check - When the indicator at the top of the clamp is flush this shows that the correct clamping force is applied to the fitting.

Code	Description	Weight	Delivery Code
		Kg	
TLOADCLAMPA	63mm - 500mm top load clamp	1	A

Strap Clamp 200 Straight

Lightweight, fast set up, alignment clamps for use on 40mm - 200mm pipe. Used on couplers only.

- Lightweight construction
- Fast acting 'tug and tension' straps

- Works above, below or alongside the joint
- Compact design
- No liners required



Code	Description	Range	Weight	Delivery Code
		mm	Kg	
SC200-2-S	Straight runner bar with 2 clamps	40 - 200	2.5	A
SC200-2-S-4	Straight runner bar with 4 clamps	40 - 200	4.6	A

Note: to use the strap clamp 200 straight to clamp tees, a T-Adaptor is required.

Strap Clamp 200 Knuckle

Lightweight, fast set up, alignment clamps for use on 40mm - 200mm pipe. A centrally located adjustable knuckle allows the SC200-2-K to be used for 22.5°, 45° and 90° elbows, reducers and couplers.

- Lightweight construction
- Fast acting 'tug and tension' straps
- Works above, below or alongside the joint
- Compact design
- No liners required



Code	Description	Range	Weight	Delivery Code
		mm	Kg	
SC200-2-K	Knuckle bar with 2 clamps	40 - 200	2.7	A
SC200-2-K-4	Knuckle bar with 4 clamps	40 - 200	4.6	

Note: to use the strap clamp 200 knuckle to clamp tees, a T-Adaptor is required.



Strap Clamp Titan 200

Lightweight, fast set up, alignment clamp for use on 40mm - 200mm pipe. Used on couplers only. The Titan clamp pulls the pipe into position with minimal effort using a rack and pinion system.

- Ratchet handle included
- Lightweight construction
- Fast acting 'tug and tension' straps
- Works above, below or alongside the joint
- Compact design
- No liners required



Code	Description	Range	Weight (kg)	Delivery Code
		mm	Kg	
SC200T	Straight ratchet runner bar with 4 clamps	40 - 200	6.5	B

Strap Clamp 500 Straight

Fast set up alignment clamp, for use on 160mm - 500mm pipe. Used on couplers only.

- Lightweight robust construction
- Fast acting 'tug and tension' straps
- Works above, below or alongside the joint
- Compact design
- No liners required



Code	Description	Range	Weight (kg)	Delivery Code
		mm	Kg	
SC500	Plain runner bar with 2 clamps	160mm - 500mm	8	B
12799	V block clamp assembly	160mm - 500mm	1.5	B

Note: to use the strap clamp 500 straight to clamp tees, a T-Adaptor is required.

Strap Clamp Titan 500

Fast set up, alignment clamp for use on 160mm - 500mm pipe. Used on couplers only. The Titan clamp is capable of pulling 12m lengths of pipe into position, using a rack and pinion system.

- Ratchet handle included
- Fast acting 'tug and tension' straps
- Works above, below or alongside the joint
- Compact design
- No liners required



Code	Description	Range	Weight	Delivery Code
		mm	Kg	
SC500T	Straight ratchet runner bar with 4 clamps	160-500	20	B

T-Adaptor

The T-adaptor is an add-on tool enabling strap clamps to be used for clamping tees. To use the T-Adaptor a further V-Block clamp needs to be purchased.

- The T-adaptor can either be used on the SC200 or SC500 range.



Strap clamp with T-Adaptor fixed in place

T-Adaptor

Code	Description	Range	Weight	Delivery Code
		mm	Kg	
SC200ADT	T-Adaptor for strap clamp 200	40 - 200	0.3	B
SC500ADT	T-Adaptor for strap clamp 500	160 - 500	3.4	B
34989	V block clamp assembly for 200 T-Adaptor	40 - 200	0.6	B
12799	V block clamp assembly for 500 T-Adaptor	160 - 500	1.5	B

Hydraulic Pipe Clamps

Hydraulically powered re-rounding and positioning clamps for supporting and restraining large diameter pipes and couplers throughout the electrofusion process.

- Made from fabricated steel construction
- Hydraulic power provided by 2 hand pumps
- Excellent re rounding capability
- 3 segment pipe clamps, disassemble for ease of transportation
- Available with straight base only
- Can be used as alignment kit
- Steel reducing liners available on request
- Single clamp available on request



Code	Description	Weight (kg)	Delivery Code
		Kg	
HRR400KIT	Hydraulic rerounding clamp 400mm	50	C
HRR500KIT	Hydraulic rerounding clamp 500mm	68	C
HRR630KIT	Hydraulic rerounding clamp 630mm	79	C
HRR710KIT	Hydraulic rerounding clamp 710mm	89	C
HRR800KIT	Hydraulic rerounding clamp 800mm	125	C
HRR900KIT	Hydraulic rerounding clamp 900mm	155	C

Note: Each kit is supplied with two clamps, two hand pumps, two hydraulic cylinders, and two alignment bars.



Rerounding/Post Squeeze Off Clamps

Designed for re rounding pipes after squeeze off has been applied.

- Rerounds the pipe effectively covering a large surface area.



Code	Range	Weight (kg)	Delivery Code
		Kg	
RRC50	50mm	2.9	A
RRC63	63mm	3	A
RRC75	75mm	3.5	A
RRC90	90mm	3.5	A
RRC110	110mm	5.8	A
RRC125	125mm	5.5	A
RRC140	140mm	5.5	A
RRC160	160mm	7.5	A
RRC180	180mm	6.8	A
RRC200	200mm	9.3	A
RRC225	225mm	11.5	A
RRC250	250mm	12	A

Rerounding Tools

A range of re rounding tools for use on polyethylene coiled or oval pipe prior to electrofusion.

- Quick and simple to use.



Rerounding tool
20mm - 32mm

Rerounding tool
40mm - 90mm

Rerounding tool
110mm - 250mm

Product code	Range	Weight (kg)	Delivery Code
		Kg	
RRT20	20mm	0.5	A
RRT25	25mm	0.5	A
RRT32	32mm	0.5	A
RRT40	40mm	1.5	A
RRT50	50mm	1.3	A
RRT63	63mm	1.3	A
RRT75	75mm	1.5	A
RRT90	90mm	1.5	A
RRT110	110mm	2.0	A
RRT125	125mm	2.0	A
RRT160	160mm	2.3	A
RRT180	180mm	3.0	A
RRT200	200mm	3.0	A
RRT225	225mm	3.0	A
RRT250	250mm	3.0	A



Mini Squeeze Tool



The mini squeeze tool is designed solely for use on SDR 11 service pipes in the range 16mm to 32mm diameter.

- Manufactured from cast stainless steel
- Compact robust design
- User friendly
- Unique design incorporates built-in safety stops to prevent damage to the pipe

Code	Description	Weight (kg)	Delivery Code
		Kg	
SQT32	16mm - 32mm mini squeeze tool	1	A

Service Squeeze Tool



The service squeeze tool is for flow stopping on 16, 20, 25, 32, 40, 50 and 63mm pipes.

- Cast steel construction
- Hand indexable stops

Code	Description	Weight (kg)	Delivery Code
		Kg	
SQT63	16mm - 63mm service squeeze tool (UK)	6	A
SQT63X10	16mm - 63mm service squeeze tool (Export)	6	A

Mechanical Squeeze Tool



Mechanical squeeze off tool for pipe 63mm-125mm diameter

- Can be used on SDR 11 pipe between sizes 63 and 90mm
- Can be used on SDR17.6 pipe between sizes 90, 110 and 125mm.
- Fabricated steel construction
- Hand indexable stops

Code	Description	Weight (kg)	Delivery Code
		Kg	
SQT125M	63 - 125mm mechanical squeeze tool	9	A

200 Hydraulic Mains Squeeze Tool



Hydraulic mains squeeze tool used as a flow stop on 63mm - 200mm diameter pipes.

- High quality hydraulic jack
- Spring return after squeeze off
- Fabricated steel construction
- Controlled release through hydraulic shut off valve
- Integral safety relief valve

Code	Description	Weight (kg)	Delivery Code
		Kg	
SQT200	200mm squeeze tool with stops for SDR 11 and 17	39	B
SQT200UK	200mm squeeze tool with stops for SDR11, 17 and SDR21	39	B



250 Mains Squeeze Tool



The 250 mains squeeze tool can be used for flow stopping on 180mm-250mm pipe. Pipe stops need to be ordered separately for each diameter and SDR rating. Tool supplied with 4 beam sets

- 'A' frame design, robust construction for in-trench work
- The 'A' frame can be detached and used with an additional beam set which allows up to four squeeze-off points to be carried out efficiently with one tool.
- Controlled release through hydraulic shut off valve

Code	Description	Weight (kg)	Delivery Code
		Kg	
SQT250AHP-2	SQT250 manual squeeze off tool 4 beam set with hand pump	180	B
SQT250AAI	SQT250 auto hydraulic squeeze off tool 4 beam set with air intensifier	190	B

400 Mains Squeeze Tool



The 400 mains squeeze tool can be used for flow stopping on 250mm-400mm pipe. Pipe stops need to be ordered separately for each diameter and SDR rating. Tool supplied with 4 beam sets.

- Very robust construction
- The cylinders can be detached and used with other beam sets which allows up to four squeeze off points to be carried out efficiently with one tool
- Controlled release through hydraulic shut off valve

Code	Description	Weight (kg)	Delivery Code
		Kg	
SQT400	SQT400 auto hydraulic squeeze off tool, 4 beam set with air intensifier	430	C
SQT400E	SQT400 auto hydraulic squeeze off tool, 4 beam set with electric pump	430	C

Generators



Fusion's range of generators are specifically manufactured for powering both electrofusion control boxes and automatic butt fusion machines. All Fusion generators produce a high quality, smooth, regular power output. All generators comply with the Tin12 (EC3) specification, are available in petrol or diesel engines, and meet the current EC regulations.

Generators are tailored to suit your own specific requirements, please contact us for further details.

Code	Description	Delivery Code
P501	Generator 5KVA on frame (skids)	B
P501WF	Generator 5KVA on wheeled frame	B
P750	Generator 7.5KVA on frame (skids)	B
P750WF	Generator 7.5KVA on wheeled frame	B

Please state which output voltage and sockets required at the time of ordering.

Butt fusion power requirements

Machine description	Select generator output voltage (V)		Minimum power required	
	110V single phase	220V single phase	kW	kVA
GATOR 180	Yes	Yes	2.9	3.6
GATOR 250	Yes	Yes	3.2	4.0
GATOR 315	Yes	Yes	4.8	6.0
GATOR 400	Yes	Yes	5.6	7.0

Electrofusion power requirements

Machine description	Select generator output voltage (V)	Minimum power required	
	220V single phase	kW	kVA
SBOX LITE 220	Yes	2.2	2.8
SBOX-MAX	Yes	4.8	6.0

Hand Scraper



Code	Description	Weight	Spare blade code	Delivery Code
		Kg		
HARRIS	1.5" hand scraper	0.1	60122	A
HARRISLGE	2.5" hand scraper	0.1	60233	A

Secateurs



Code	Description	Weight	Delivery Code
		Kg	
PCS2032M	16mm - 42mm small secateur cutter	0.3	A
PCS2063SH	20mm - 63mm large secateur cutter (short handle)	1.5	A
PCS2063	20mm - 63mm large secateur cutter (long handle)	2	A

Jumbo Pipe Cutter



Code	Description	Weight	Spare Blade code	Delivery Code
		Kg		
PCJ315	160 - 355mm jumbo pipe cutter	24	PCJBLADE	B
PCJ630	355mm - 630mm jumbo pipe cutter	28	PCJBLADE	B
PCJ800	355mm - 800mm jumbo pipe cutter	31	PCJBLADE	B

Guillotine Cutter



Code	Description	Weight	Spare blade code	Delivery Code
		Kg		
PCG125	63mm - 125mm guillotine cutter	7.5	60449	B
PCG200	63mm - 225mm guillotine cutter	15	11774	B
PCG315	63mm - 315mm guillotine cutter	33	11923	B

Cutter Key

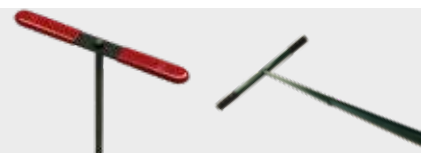

Code	Description	Weight	Delivery Code
		Kg	
CUTKEY12	Universal tapping tee cutter key (with cutter key and wrench)	0.6	A
CUTTERKEYEXL	Universal tapping tee cutter key extended length - 1000mm	1.3	A

Test Caps



Code	Description	Weight	Delivery Code
		Kg	
22869	63mm aluminium multiseal test cap	0.4	A
34571	63mm multiseal test cap	0.1	A
34263	32mm multiseal test cap	0.1	A



Fastcut Drill

Fusion's range of large diameter electrofusion branch saddles provides the gas and water installer with a simple alternative to the high cost of by-pass systems or the inconvenience and associated costs of supply interruptions. Under pressure drilling provides the operator with a simple, safe and cost-effective method of branch installation.

- Installation training provided
- Modular construction ensures ease of handling and assembly
- Hydraulic operation of cutter head helps the operator with cutting through the pipe
- Can be used with plate or gate valves
- Dedicated cutter drive prevents penetration beyond centre line of main
- Swarf and coupon retained inside cutter
- Drill comes complete with 3 heads as standard - 250, 200 and 150 NP16
- ANSI standard version available upon application
- Rotational/adjustable jack to aid alignment
- Pendant cutter control with timer to allow single operator cut through

Code	Description	Branch Saddle Range	Weight	Delivery Code
			Kg	
FASTCUT355110V	Fastcut drill UK	250mm-500mm	197	C
FASTCUT355220V	Fastcut drill Export	250mm-500mm	197	C

Large Diameter Branch Saddles



- Complete with sacrificial under parts - no additional tooling needed
- Minimal pressure drop due to large bore through fitting
- Large electrofusion area ensures integrity of weld
- 39.5 volt fittings
- Tested in accordance with industry specifications

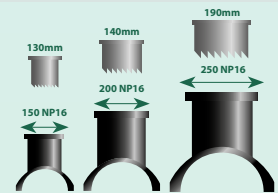

Outlet sizes available: 150, 200, 250 NP16

Branch Saddle Size mm	Pipe Material	UK GAS APPLICATIONS (GIS)				UK / EUROPEAN WATER APPLICATIONS				EUROPEAN GAS APPLICATIONS						
		Maximum Operating Pressure	Pipe SDR				Maximum Operating Pressure	Pipe SDR				Maximum Operating Pressure	Pipe SDR			
			11	17.6	21	26		11	17.6	21	26		11	17.6	21	26
250x150 NP16	PE80	5.5 bar	✓	✓	✓	-	16 bar	✓	✓	✓	-	10 bar	✓	✓	✓	-
	PE100		✓	✓	✓	-		✓	✓	✓	-		✓	✓	✓	-
250x200 NP16	PE80	5.5 bar	✓	✓	✓	-	16 bar	✓	✓	✓	-	10 bar	✓	✓	✓	-
	PE100		✓	✓	✓	-		✓	✓	✓	-		✓	✓	✓	-
280x150 NP16	PE80	TBA	-	-	-	-	16 bar	✓	✓	✓	-	10 bar	✓	✓	✓	-
	PE100		✓	✓	✓	-		✓	✓	✓	-		✓	✓	✓	-
280x200 NP16	PE80	5.5 bar	✓	✓	✓	-	16 bar	✓	✓	✓	-	10 bar	✓	✓	✓	-
	PE100		✓	✓	✓	-		✓	✓	✓	-		✓	✓	✓	-
315x150 NP16	PE80	7 bar	✓	✓	✓	✓	16 bar	✓	✓	✓	✓	10 bar	✓	✓	✓	✓
	PE100		✓	✓	✓	✓		✓	✓	✓	✓		✓	✓	✓	✓
315x250 NP16	PE80	7 bar	✓	✓	✓	✓	16 bar	✓	✓	✓	✓	10 bar	✓	✓	✓	✓
	PE100		✓	✓	✓	✓		✓	✓	✓	✓		✓	✓	✓	✓
355x150 NP16	PE80	7 bar	✓	✓	✓	✓	16 bar	✓	✓	✓	✓	10 bar	✓	✓	✓	✓
	PE100		✓	✓	✓	✓		✓	✓	✓	✓		✓	✓	✓	✓
355x250 NP16	PE80	7 bar	✓	✓	✓	✓	16 bar	✓	✓	✓	✓	10 bar	✓	✓	✓	✓
	PE100		✓	✓	✓	✓		✓	✓	✓	✓		✓	✓	✓	✓
400x150 NP16	PE80	5.5 bar	✓	✓	✓	✓	16 bar	✓	✓	✓	✓	10 bar	✓	✓	✓	✓
	PE100		-	✓	✓	✓		✓	✓	✓	✓		✓	✓	✓	✓
400x250 NP16	PE80	5.5 bar	-	✓	✓	✓	10 bar	✓	✓	✓	✓	6 bar	✓	✓	✓	✓
	PE100		-	✓	✓	✓		-	✓	✓	✓		✓	-	✓	✓
450x150 NP16	PE80	5.5 bar	-	✓	✓	✓	10 bar	✓	✓	✓	✓	6 bar	✓	✓	✓	✓
	PE100		-	✓	✓	✓		-	✓	✓	✓		✓	-	✓	✓
450x250 NP16	PE80	5.5 bar	-	✓	✓	✓	10 bar	✓	✓	✓	✓	6 bar	✓	✓	✓	✓
	PE100		-	✓	✓	✓		-	✓	✓	✓		✓	-	✓	✓
500x150 NP16	PE80	5.5 bar	-	✓	✓	✓	10 bar	✓	✓	✓	✓	6 bar	✓	✓	✓	✓
	PE100		-	✓	✓	✓		-	✓	✓	✓		✓	-	✓	✓
500x250 NP16	PE80	5.5 bar	-	✓	✓	✓	10 bar	✓	✓	✓	✓	6 bar	✓	✓	✓	✓
	PE100		-	✓	✓	✓		-	✓	✓	✓		✓	-	✓	✓
630x150 NP16	PE80	5.5 bar	✓	✓	✓	✓	16 bar	✓	✓	✓	✓	10 bar	✓	✓	✓	✓
	PE100		✓	✓	✓	✓		✓	✓	✓	✓		✓	✓	✓	✓
Flow stop 315x150 NP16	PE80	2 bar	-	✓	✓	✓	-	-	-	-	-	10 bar	✓	✓	✓	✓
	PE100		✓	✓	✓	✓	✓	✓	✓	✓	✓		✓	✓		
Flow stop 355x150 NP16	PE80	2 bar	-	✓	✓	✓	-	-	-	-	-	10 bar	✓	✓	✓	✓
	PE100		✓	✓	✓	✓	✓	✓	✓	✓	✓		✓	✓		
Flow stop 400x150 NP16	PE80	2 bar	-	✓	✓	✓	-	-	-	-	-	10 bar	✓	✓	✓	✓
	PE100		✓	✓	✓	✓	✓	✓	✓	✓	✓		✓	✓		

ACCESS SYSTEMS FOR GAS AND WATER



Fusion offers a very comprehensive range of surface boxes in various material combinations: synthetic body with synthetic lids, synthetic body with cast iron lids, synthetic body with ductile iron surface plate/lid as well as cast iron body and lid.

Boundary Boxes

The AVK PENTOBX range of Water Meter Boundary Boxes, comprises of a class leading, composite Grade B surface box able to withstand an 8 tonne loading and allowing, if required, Automated Meter Reading Technology (AMR). With patented push-fit connections in d20, 25 and 32mm, ½" HG and also ¾" BSP Female threaded.

Surface boxes

Surface boxes are available in a floating design and a fixed/floating reversible design. The reversible surface box allows for deflection and internal fixation of telescopic extension spindles from both ends.

The fixed surface boxes of grey cast iron are height adjustable using ductile iron distance rings of a height of 10-50 mm.

Fixed height surface boxes

Our fixed height synthetic surface boxes are DIN DVGW approved and designed to withstand heavy traffic loads. Therefore, they are often used in medium and heavy duty application areas.

Our Futura range is a lightweight and price competitive version and is often used in light to medium duty application areas.

Height adjustable surface boxes

Fusion offers a wide range of DIN DVGW approved height adjustable surface boxes specifically designed for tarmac installation. The use of height adjustable surface boxes enables easy and precise installation thanks to flexible positioning of the top part. The top part ensures a safe and lasting alignment with the road surface preventing costly and time consuming corrections after installation and when roads are renovated.

As with all valves, best practice techniques should be used during installation and operation. To aid this process a series of recommended accessories is available, this includes a reliable installation and access system and retrofit extension spindles.

The valve access system consists of a support base, down pipe, surface box adaptor and surface box. The support base creates stability for the valve and avoids twisting of the pipe, but it also absorbs high loads and centres the down pipe installed on top of the valve ensuring valve operation at all times. The adaptor and surface box complete the valve access system. Besides giving access to the lower buried valve the surface box can bear media identification for easy recognition and, if required, customer specific logos.





AVK PENT  **BOX**

INSTALLATION MANUAL

AVK PENTOBX

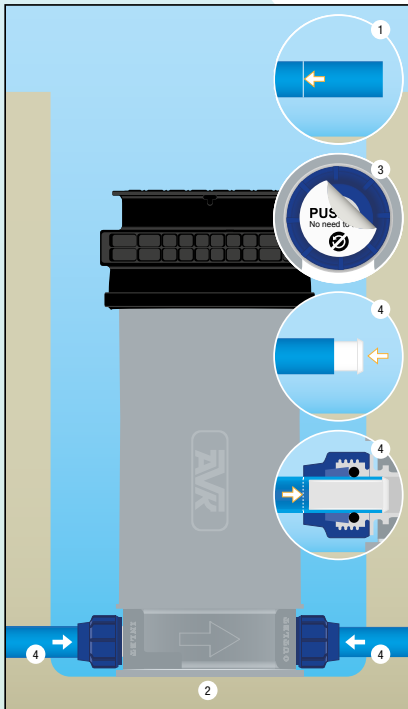

1. Mark the pipe 54mm from the end.
2. Prepare hole with level base.
3. Remove stickers from push fit connections and take plastic sleeves out of push fit.
4. Place sleeves into pipes and insert pipes into push fit connections (no need to twist). Push pipe as far as marked in step 1.

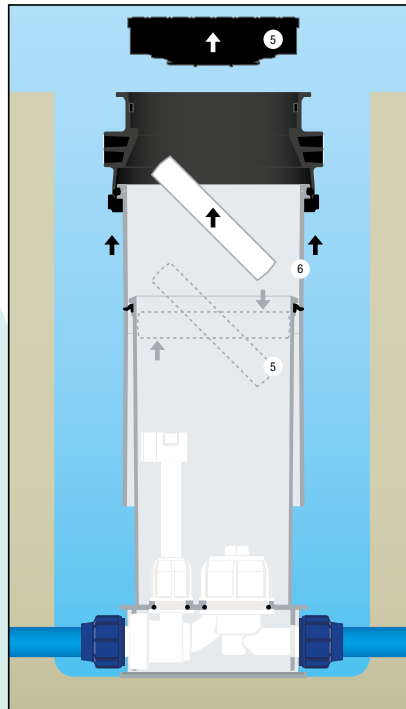

5. Remove cover and insulation pad. To remove the insulation pad, push one side down to be able to take it out. Store cover and pad in a clean area.
6. Adjust height of telescopic boundary box.

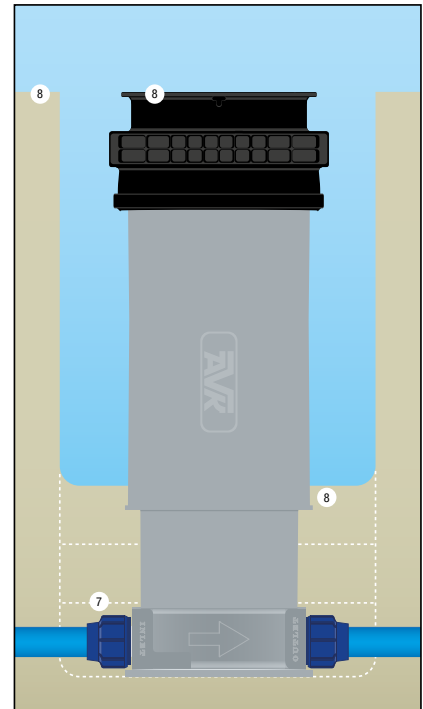

7. Fill hole with gravel in steps of ± 100 mm layers and compact each layer.
8. When the gravel is ± 50 mm over the outer sleeve, the top of the boundary box needs to be adjusted with the ground level.

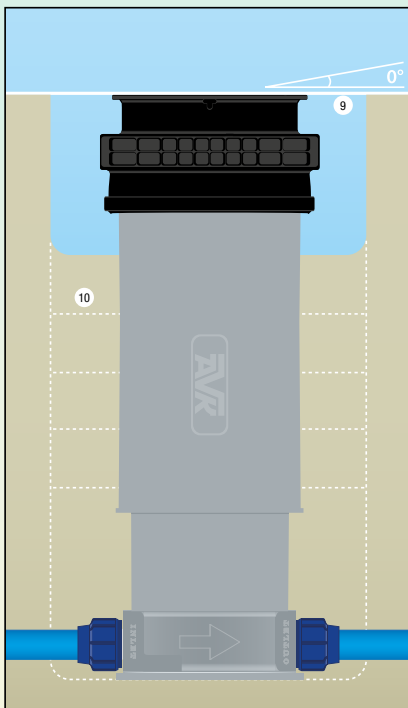

9. Use a straight edge to make sure the top of the boundary box is perfectly aligned with the ground level.
10. Continue filling the hole with ± 100 mm layers of gravel and compact thoroughly at each step.



11. For high load bearing requirements it is necessary to lay sufficient support, from 30mm under the cover frame up to the top of the cover frame.

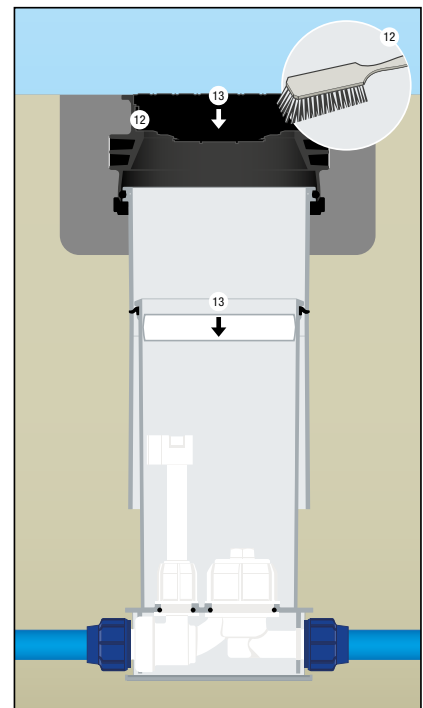

12. Clean the seal area in the cover frame so it is clear of debris.
13. Reinsert the insulation pad and place the cover onto the boundary box.



AVK PENTOBX - Water Meter Boundary Boxes

- Series 8054/2211
- Water Meter Boundary Box Grade B Version, Sealed
- Acetal manifold
- Polypropylene frame, lid, sliding guard tube
- NBR Seals
- WIS 4-37-01

- WRAS approved
- PN16

Liner included where required



Code	d	PN	Delivery Code
	mm / inch	Bar	
8054-120-2211-10301000	20 Push-fit	16	C
8054-125-2211-10301000	25 Push-fit	16	C
8054-132-2211-10301000	32 Push-fit	16	C
8054-121-2211-10301000	½" HG Push-fit	16	C
8054-221-2211-10301000	½" HG Comp	16	C
8054-326-2211-10301000	¾" BSP female	16	C

- Series 8054/3211
- Water Meter Boundary Box Grade C Version, Sealed
- Acetal manifold
- Polypropylene frame, lid, sliding guard tube
- NBR Seals
- WIS 4-37-01

- WRAS approved
- PN16

Liner included where required



Code	d	PN	Delivery Code
	mm / inch	Bar	
8054-120-3211-10301000	20 Push-fit	16	C
8054-125-3211-10301000	25 Push-fit	16	C
8054-132-3211-10301000	32 Push-fit	16	C
8054-121-3211-10301000	½" HG Push-fit	16	C
8054-221-3211-10301000	½" HG Comp	16	C
8054-326-3211-10301000	¾" BSP female	16	C

- Series 8054/2202
- Water Meter Boundary Box Grade B Version, Unsealed
- Acetal manifold
- Polypropylene frame, lid, sliding guard tube
- NBR Seals
- WIS 4-37-01

- WRAS approved
- PN16

Liner included where required



Code	d	PN	Delivery Code
	mm / inch	Bar	
8054-120-2202-10301000	20 Push-fit	16	C
8054-125-2202-10301000	25 Push-fit	16	C
8054-132-2202-10301000	32 Push-fit	16	C
8054-121-2202-10301000	½" HG Push-fit	16	C
8054-221-2202-10301000	½" HG Comp	16	C
8054-326-2202-10301000	¾" BSP female	16	C



AVK PENTOBX - Water Meter Boundary Boxes

- Series 8054/3202
 - Water Meter Boundary Box Grade C Version, Unsealed
 - Acetal manifold
 - Polypropylene frame, lid, sliding guard tube
 - NBR Seals
 - WIS 4-37-01
 - WRAS approved
 - PN16
- Liner included where required



Code	d	PN	Delivery Code
	mm / inch	Bar	
8054-120-3202-10301000	20 Push-fit	16	C
8054-125-3202-10301000	25 Push-fit	16	C
8054-132-3202-10301000	32 Push-fit	16	C
8054-121-3202-10301000	½" HG Push-fit	16	C
8054-221-3202-10301000	½" HG Comp	16	C
8054-326-3202-10301000	¾" BSP female	16	C

Accessories for AVK PENTOBX

Code	Item	Delivery Code
605970060	Blanking Plug Full-flow	C
605970120	Long Valve Handle	C
605970120	Short Valve Handle	C
605970901	Check Valve Assembly	C
942700050	Frost Plug	C
605970921	Lid Grade B	C
TBC	Sliding Guard Tube, Cover Frame & Lid Grade B	C

Additional Products



SERIES 8054/5211
Water Meter Boundary Box Grade B version
BS 5834-1:2017
PN16
d20-32, ¾" BSP, ½" HG
Square PP frame



SERIES 8054/6211
Water Meter Boundary Box Grade C version
BS 5834-1:2017
PN16
d20-32, ¾" BSP, ½" HG
Square PP frame

SURFACE BOXES

PRODUCT OVERVIEW

Fusions's wide range of **surface boxes** granting access to lower buried valves at all times.

Ideal transition between surface box and down pipe by use of a **surface box adaptor**.

Flexible height adjustment with cut to length **down pipe**.

CERTUS™ or **MAGNUS™** PE ball valve for a quick and easy connection using **Electrofusion couplings** to the existing pipeline

Robust **support base** avoids twisting of the pipe and offers stability.



SURFACE BOXES

PRODUCT TYPES



CLASSIC FIXED HEIGHT

- Design according DIN/EN, DVGW certified
- Cast iron lids available for all surface boxes
- Synthetic lids available for most surface boxes

CLASSIC PAVEMENT

- Design derived from DIN/EN
- Special range for pavement installation
- Cast iron lids and synthetic lids available



CLASSIC HEIGHT ADJUSTABLE

- Design according to DIN/EN, DVGW certified
- Special range for tarmac installation
- Easy and precise installation
- No costly corrections after installation

CLASSIC HEIGHT ADJUSTABLE WITH REINFORCED RIM

- Design derived from DIN/EN
- Special range for tarmac installation
- Strong rim also makes range especially suitable for heavy duty application areas



FUTURA FIXED HEIGHT AND PAVEMENT

- Design derived from DIN/EN
- Cast iron lids and synthetic lids available
- Range available with round or square top

SPECIALS

- Customer specific design
- Surface boxes and lids available in various materials
- Various lid inscriptions possible



ACCESSOIRES

- Wide variety of accessories available
- Enable complete system solutions
- Sustainable solutions extend product lifetime



Fixed Height Surface Box

- Series 80/32-200
- Fixed height surface box for service connection valves
- Square top
- Cast iron lid
- PA+ body



Code	Weight	Units	Delivery Code
	Kg	Per pallet	
80-32-2000000	3.1	96	C

Height Adjustable Surface Box

- Series 80/32-100
- Height adjustable surface box for service connection valves according to DIN 4057
- Cast iron lid
- PA+ body



Code	Weight	Units	Delivery Code
	Kg	Per pallet	
80-32-1000000	3.7	96	C

Additional Products

	<p>SERIES 80/32-011 Fixed height surface box for service connection valves - Futura design - cast iron lid PA+ Body</p>		<p>SERIES 80/31-211 Fixed height surface box for distribution valves - Futura design - square top - cast iron lid PA+ Body</p>		<p>SERIES 80/33-000 Surface box for service connection valves, design derived from DIN 4059 Fixed height. Cast iron lid, standard inscription: GAS PA+ Body</p>
	<p>SERIES 80/32-211 Fixed height surface box for service connection valves - Futura design - square top - cast iron lid PA+ Body</p>		<p>SERIES 80/33-400 Surface box for service connection valves, design derived from DIN 4059 Height adjustable Reinforced rim PA+ Body</p>		<p>SERIES 80/33-100 Surface box for service connection valves, design derived from DIN 4059 Cast iron lid, standard inscription: GAS. Height adjustable PA+ Body</p>
	<p>SERIES 80/34-100 Surface box for distribution valves, design according to DIN 3581 Height adjustable. Cast iron lid, standard inscription: GAS PA+ Body</p>		<p>SERIES 80/34-000 Surface box for distribution valves, design according to DIN 3581 Fixed height. Cast iron lid, standard inscription: GAS PA+ Body</p>		<p>SERIES 80/40 Fixed height surface box for distribution valves Cast iron lid PE body</p>

INSTALLATION MANUAL

FIXED HEIGHT SURFACE BOX

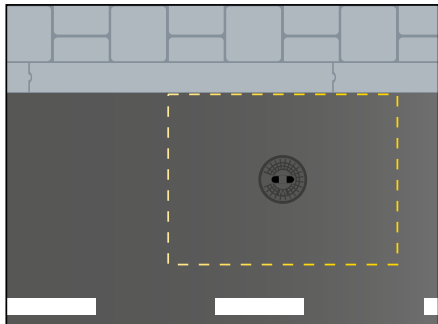

Final situation

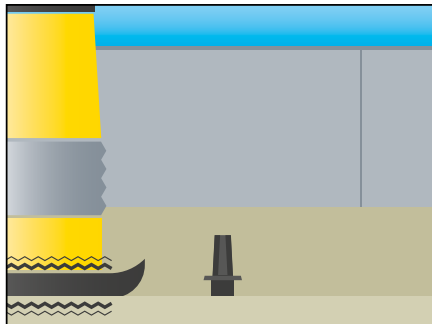

1. Compact the subsoil.

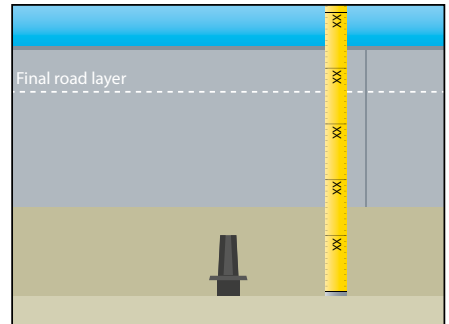

2. Determine the final height of the surface box.

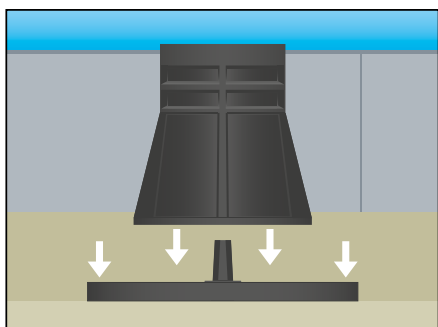

3. Place the support tile on the subsoil around the spindle and centre the surface box on the support tile.

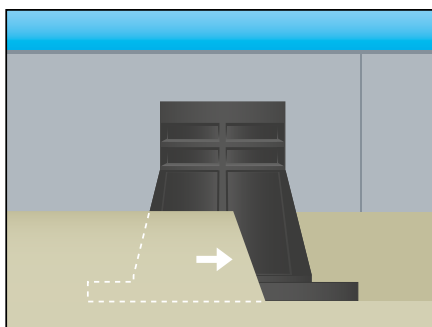

4. Surround the surface box with soil/concrete.

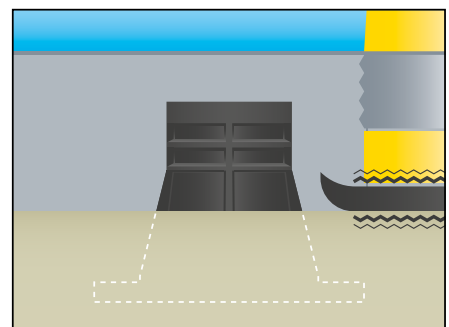

5. Compact the surrounding soil.

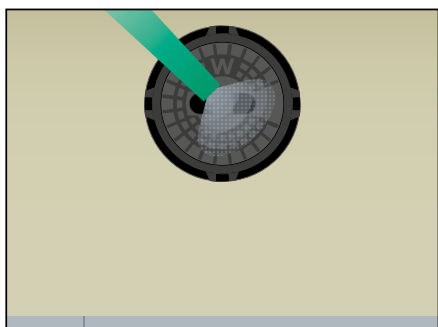

6. Apply release agent on the lid.

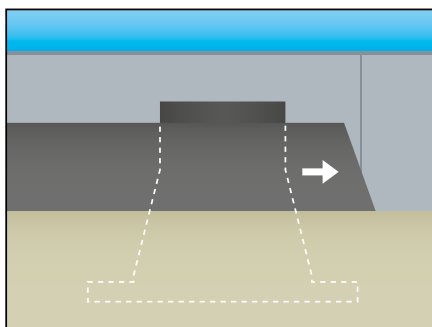

7. Apply the first layer of tarmac.

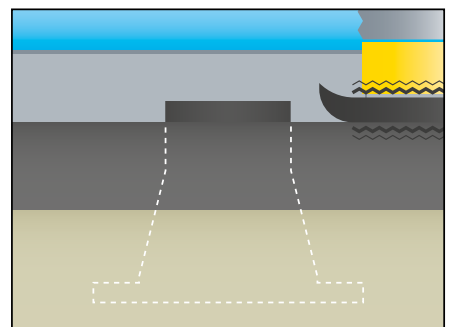

8. Compact the tarmac around the surface box.

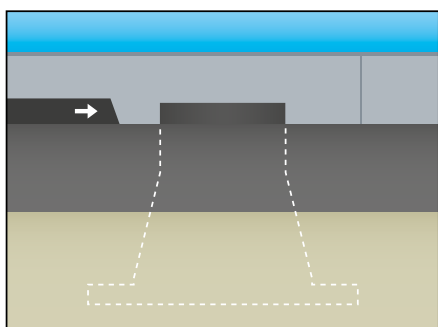

9. Apply the final layer of tarmac.

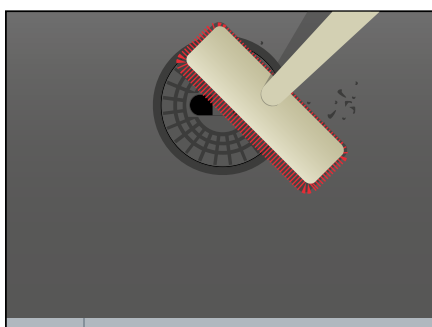

10. Clean the top of the surface box.

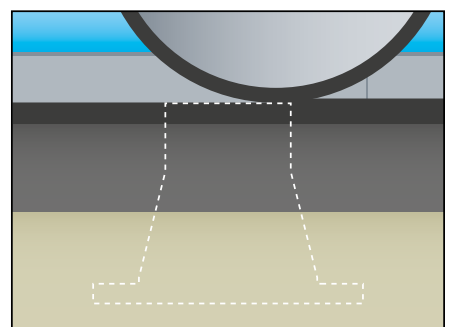

11. Use a roller to compact the final layer.

INSTALLATION MANUAL

ADJUSTABLE HEIGHT SURFACE BOX

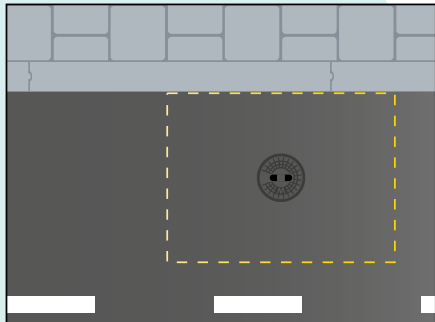

Final situation

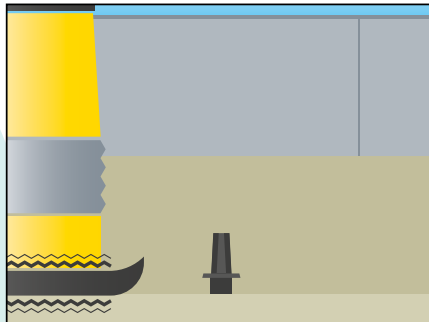

1. Compact the subsoil.

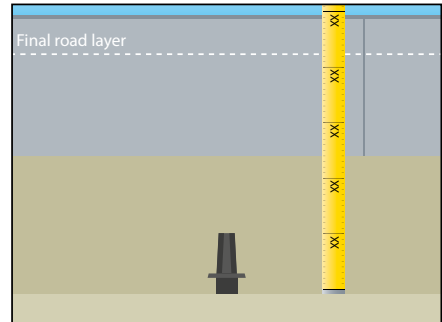

2. Determine the final height of the surface box.

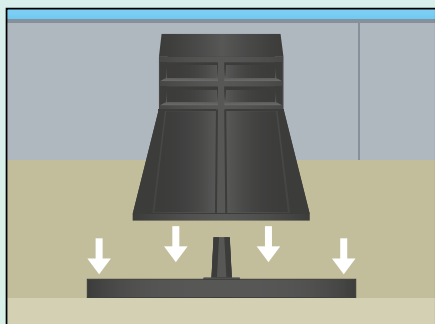

3. Place the support tile on the subsoil, centre the surface box on the support tile and make sure the top part is in the lowest position.

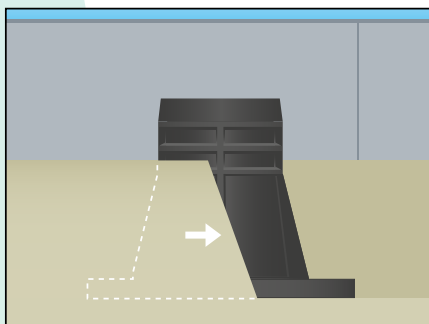

4. Surround the surface box with soil/concrete.

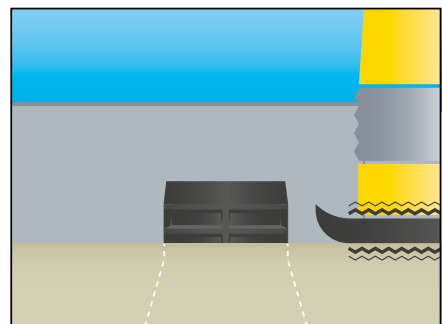

5. Compact the surrounding soil.

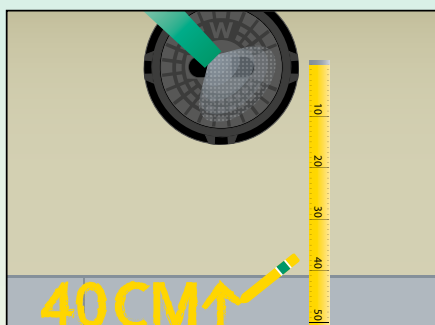

6. Mark the position of the surface box on the curbstone and apply release agent on the lid.

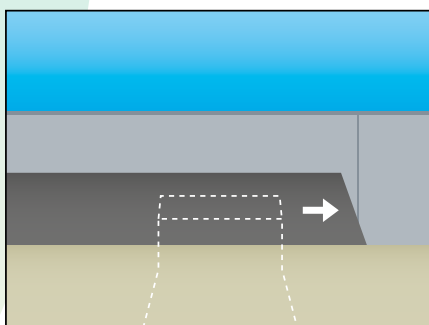

7. Apply the first layer of tarmac. Completely cover the surface box.

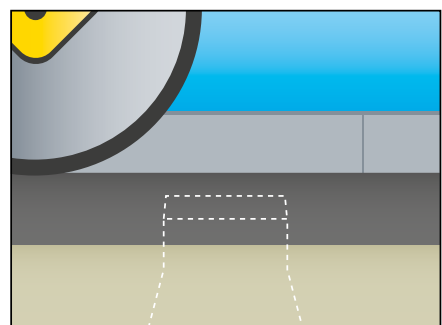

8. Use a roller to compact the tarmac layer.

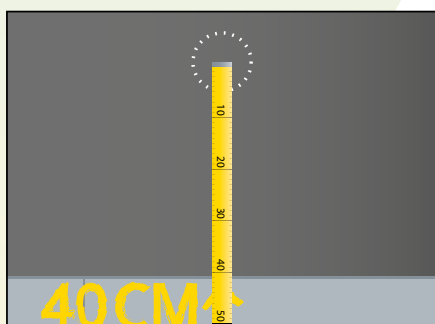

9. Locate the surface box.

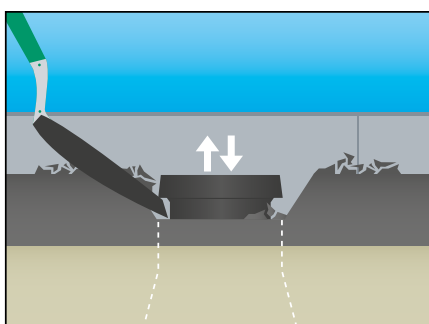

10. Free the top from tarmac and loosen the top part of the surface box. Create a slope of 45°.

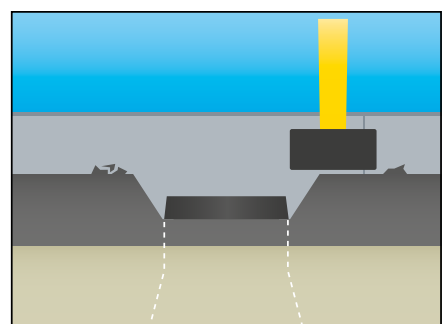

11. Compact the area surrounding the top part.

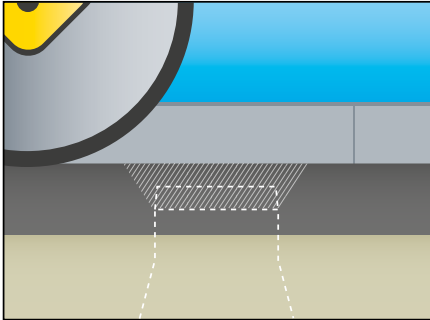

12. Use a roller to compact the first layer of tarmac

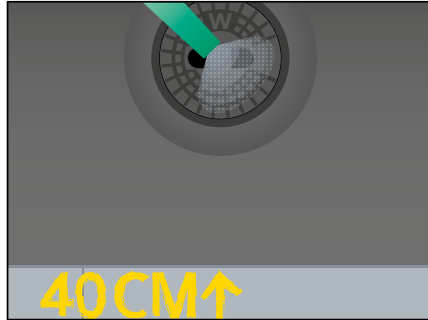

13. Apply release agent on the lid.

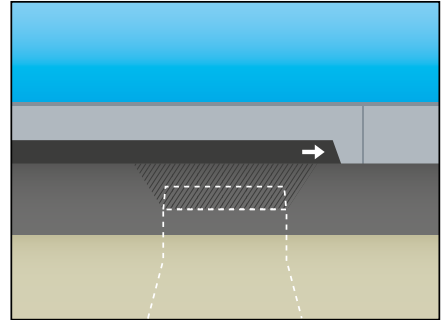

14. Apply the final layer of tarmac.

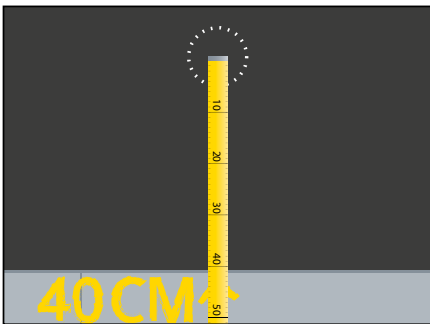

15. Locate the surface box once more.

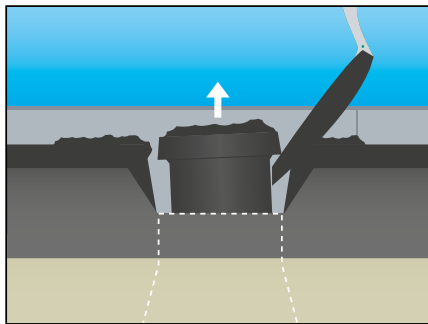

16. Lift the top part till one centimeter above the final layer.

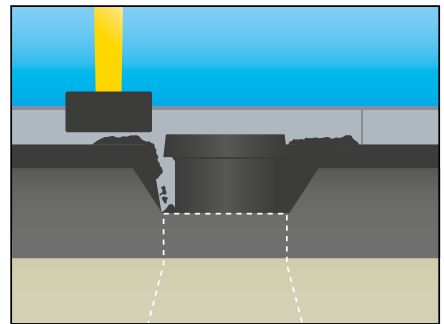

17. Clean the top of the surface box and compact the final layer of tarmac surrounding the top part.

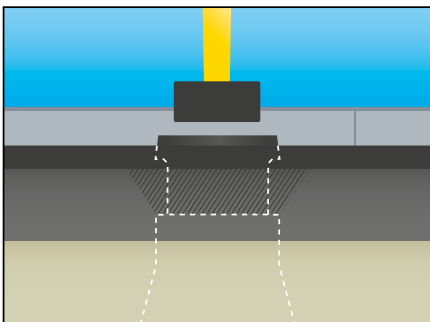

18. Compress the top of the surface box.

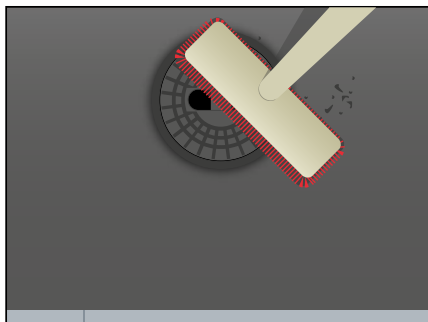

19. Clean the top of the surface box.

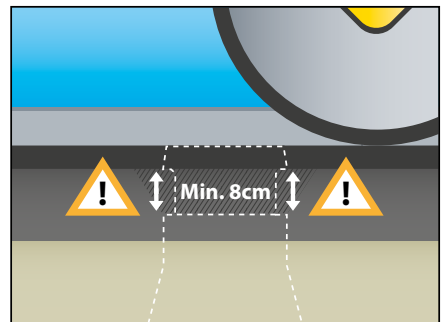

20. Use a roller to compact the final layer.



Fusion Group Limited

Chesterfield
Derbyshire
S41 9PZ
England, UK

T: +44 (0) 1246 268666
E: sales@fusiongroup.com
www.fusiongroup.com

SABAH DISTRIBUTOR:

KEKALBOLEH SDN BHD
(199901021248/496148-K)
Lot No. 7, Lorong Perindustrian Kolombong Jaya,
Pusat Perindustrian Kolombong Jaya,
Mile 5.5, Jalan Kolombong,
88450 Kota Kinabalu, Sabah.
Tel/WhatsApp: 088-385555 / 013-8867570
Website: kekalboleh.com

